

**The BMW B190 Z Marine Engine with stern drive: 121 kW (165 bhp). Particularly suitable for fast planing cruisers up to 2 tons. In both single and twin installations.**

The BMW B 190 is an extremely smooth and quiet 6-cylinder inline power unit. It offers superior performance combined with low weight, compact dimensions, extremely low fuel consumption, a twin-circuit cooling system and a wide range of

standard equipment. It gives the enthusiast excellent value for money. These characteristics make this engine absolutely unique in its class.

**Special features:**

- Superior, modern engine design
- Above-average fuel economy
- Minimum power losses thanks to optimized fuel/air mixture flow
- Maximum Performance due to BMW design cross-flow and valve arrangement
- Triple hemispherical swirl-action combustion chamber
- Modern, compact twin-circuit cooling for excellent corrosion-proofing, stable running temperature to provide optimum combustion and, as a result, a considerable reduction in exhaust emissions, simpler service in winter
- Raw water pump with rubber impeller driven directly by the camshaft – no need for the additional V-belt otherwise required
- Fuel pump with steel pipes and connections: safety advantage
- The BMW flame-arrestor ensures safety and an efficient air intake silencer
- The entire electrical system complies with US Coast Guard regulations – the strictest regulations in the world
- Excellent running characteristics and outstanding smoothness thanks to the careful balancing of the crankshaft
- Engine fitted on three rubber mounts adjustable for height at the front
- High-output alternator

- Complete range of standard fittings, such as: stern drive with power trim including display (allows efficient boat trimming and, as a result, maximum fuel economy). Wide range of instruments (including, hour meter, voltmeter and warning buzzer for oil temperature, coolant temperature and trim control, all fitted as standard)
- Patented multiple-disc clutch for smooth gear shifting characteristics (allows in cases of emergency direct shift from forwards to reverse even at higher engine speeds)
- Helical bevel gears at top and bottom: smooth running and a long service life
- Full-circulation lubrication by built-in oil pump both in forward and reverse. No lubrication points on the stern drive

**Conclusion:**

The B 190 has a wide range of exceptional advantages. This applies not only to the B 190 but to all marine engines that bear the symbol of progressive engineering. BMW's complete range of marine engines for motor yachts and sailing boats offers all kinds of options and a wide choice of diesel and petrol units. You can choose from a wide range of optional extras and accessories to meet your personal requirements. And to make sure that you enjoy sheer boating pleasure for a long time to come, BMW Marine's international dealer organization has trained marine technicians at your service as well as a reliable and quick supply of parts.

**V12 Engineering**

Box 50, Ontario, Canada POX 1C0

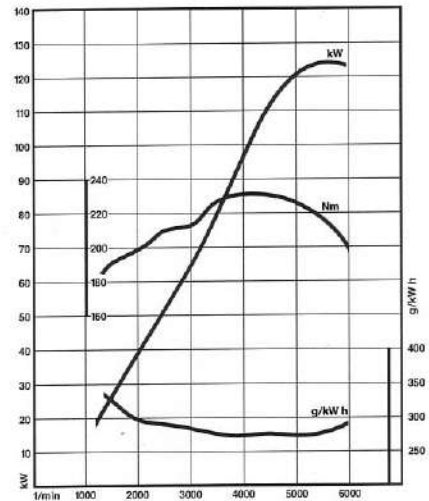
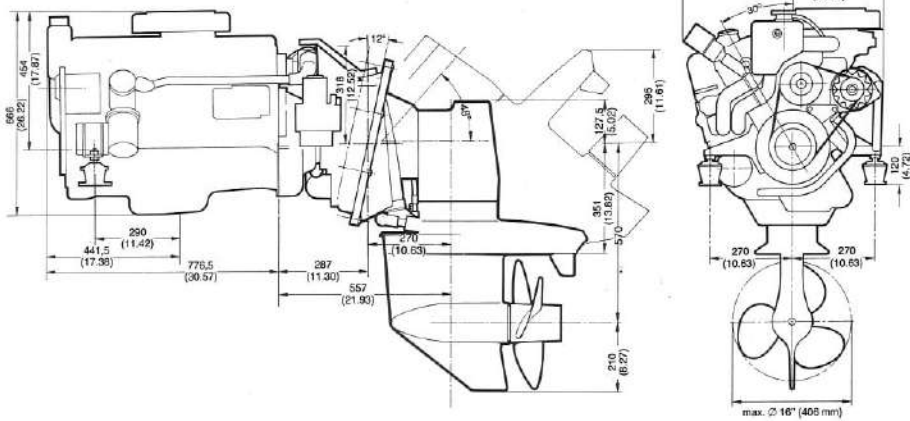

## Specifications B 190 Z

<b>Displacement and output (DIN 6270 B)</b>	Displacement 2788 cc (170.1 cu in) Stroke 80 mm (3.15"), bore 86 mm (3.38") Max output 121 kW (165 bhp) (190 SAE hp) at 5500 rpm Max torque 234 Nm (172 ft/lb) at 4000 rpm Compression ratio 8.2:1
<b>Design and installation</b>	6-cylinder 4-stroke inline engine with overhead camshaft, inclined valves in V-arrangement, forged and heat-treated steel crankshaft 12 balance weights and 7 main bearings with two oil supply holes each Engine inclined at an angle of 30° Three-point suspension; adjustable at the front, ring-shaped engine mount at the rear
<b>Weight</b>	Dry weight of engine only 253 kg (556 lb) Weight of stern drive including transom plate 74 kg (163 lb) Weight of complete, engine and stern drive unit 327 kg (719 lb)
<b>Valve drive</b>	Valve drive via rocker arms and overhead camshaft. Chain drive system with automatic, oil-damped chain tensioner and backlash guard
<b>Lubrication</b>	Forced-feed lubrication with full-flow filter and pressure control valve in filtered oil circuit, rotor oil pump driven by chain from crankshaft Full-flow filter with paper insert and check valve
<b>Fuel supply system</b>	Solex 4 A 1 dual register carburettor Fuel supply by mechanical fuel pump Air filter with flame-arrestor and air intake silencer Fuel: standard-grade, minimum rating 93 octane
<b>Engine cooling</b>	Twin-circuit cooling system with independent circuits
<b>Electrical system</b>	770 W, 14 V, 55 A alternator All electrical equipment protected against salt water
<b>Power transmission</b>	Torsion damper and universal joint; drive power transmission through multiple-disc clutch
<b>Outboard drive system/ stern drive</b>	Gear ratio: 1.95:1 right and left hand propeller rotation capability Max propeller dia 16" (406 mm) Max steering angle ± 30° Elevation angle for transport position 48° Electro-hydraulic elevation and trim system, trimmable up to an engine speed of 5500 rpm
<b>Standard fittings</b>	Engine with complete wiring and multiple-plug connections, 6-m wiring harness. Instrument panel with rev counter, hour meter, water and oil temperature gauge, voltmeter, warning lamps for oil pressure and battery charge; blank hole; warning buzzer for oil temperature and trim control, 3-stage position/ignition switch, additional instrument panel with trim rocker switch (protected from water) and trim gauge; toolkit
<b>Optional fittings</b>	Single-lever gear shift and throttle control; propeller; various additional instruments Subject to change in design and technical features

Your BMW Marine Dealer:

