



MERIDIANTM
YACHTS

580 PILOTHOUSE OWNER'S MANUAL

Date of Purchase _____

Port Engine Serial Number: _____

Starboard Engine Serial Number: _____

Hull Identification Number: _____

Hull Identification Number

- The Hull Identification Number (HIN) is located on the starboard side of the transom.
- Record the HIN (and the engine serial numbers) in the space provided above.
- Please refer to the HIN for any correspondence or orders.

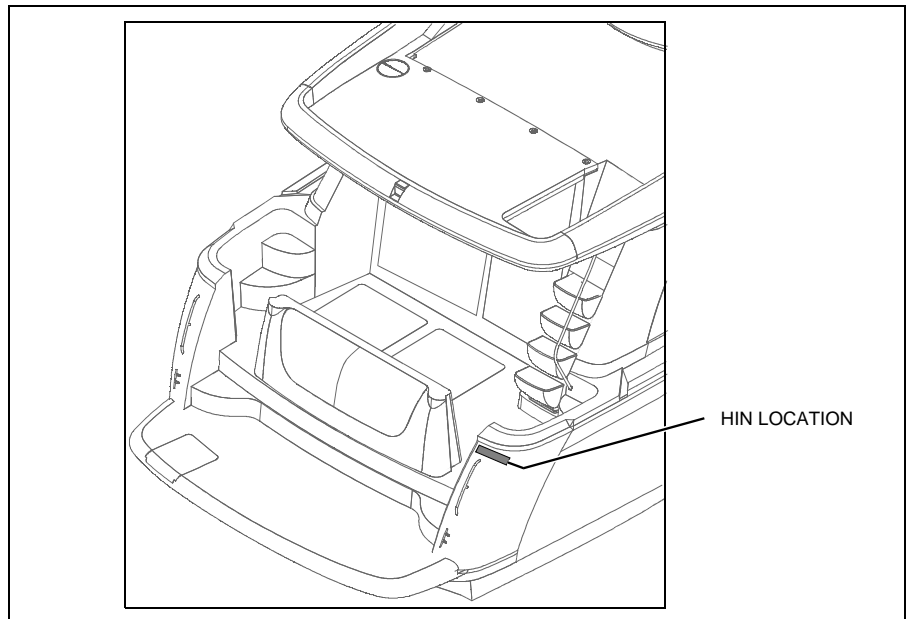

© 2004 Meridian Technical Publications. All rights reserved.

No part of this publication may be reproduced, stored in any retrieval system, or transmitted in any form by any means, electronic, mechanical, photocopying, recording or otherwise, without prior written permission of Meridian.
Printed in the United States of America.

General Notes

The material in this document is for information only and is subject to change without notice. While reasonable efforts have been made in the preparation of this document to assure its accuracy, Meridian assumes no liability resulting from errors or omissions in this document, or from the use of information contained herein. Due to our commitment to product improvement, Meridian reserves the right to make changes in the product design, specifications, and equipment at any time without notice or obligation. Illustrations and/or photos may show optional equipment.

All Meridian products meet or exceed USCG (United States Coast Guard) and/or NMMA (National Marine Manufacturer's Association) construction standards. Manufactured with 1,1,1 Trichloroethane, a substance which harms public health and environment during the manufacturing process by destroying ozone in the upper atmosphere.

Proprietary Rights

This document discloses subject matter in which Meridian has proprietary rights. The information and design disclosed herein were originated by and are the property of Meridian. Neither receipt nor possession thereof confers or transfers any right to reproduce, copy, alter or disclose the document or any part thereof, any information contained therein, or to construct boats or any item from it, except by written permission from or written agreement with Meridian. This document is to be returned upon request to Meridian.

CONTENTS

1 Chapter 1: Welcome Aboard!

- 1 Dimensions and Tank Capacities
- 1 Layout View
- 1 Dealer Service
- 2 Warranty Information
- 2 Boating Experience
- 2 Engines & Accessories Guidelines
- 2 Engine & Accessories Literature
- 3 Safety Standards
- 3 Qualified Maintenance
- 3 Structural Limitations
- 4 Special Care For Moored Boats
 - 4 *Sacrificial Anodes (Zincs)*
- 5 Boat Lifting
- 6 Carbon Monoxide (CO)
 - 6 *Facts about CO*
 - 7 *Where and How CO Can Accumulate*
 - 7 *How to Protect Yourself and Others From CO*
 - 8 *Trip Checklist*
 - 8 *Monthly Checklist*
 - 8 *Annual Checklist*
 - 8 *Carbon Monoxide Alarm System*
 - 9 *More Information*

10 Chapter 2: Locations

- 10 Exterior Views
 - 10 *Hull Views*
 - 11 *Deck Views*
 - 12 *Helm Stations*
- 13 Component Locations

27 Chapter 3: Propulsion & Related Systems

- 27 Engines
- 28 Exhaust System
- 29 Engine Room Ventilation System
- 30 Fuel System
 - 31 *Fuel Fills & Vents*
 - 31 *Fuel Transfer Pump (If Equipped)*
 - 31 *Fuel Filters*

- 32 Oil Change System (If Equipped)
- 32 Fire Suppression System (If Equipped)
- 33 Shaft-Transmission Alignment

34 Chapter 4: Controls & Gauges

- 34 Steering
- 35 Rudder Stuffing Gland
- 35 Autopilot (If Equipped)
- 36 Shift/Throttle Controls
 - 36 *Engine Synchronization (If Equipped)*
- 36 Trim Tabs
- 37 Docking On Command (D.O.C.) System (If Equipped)
- 38 Gauges
 - 38 *Cleaning Gauges*
 - 38 *Gauge Fogging*
 - 38 *Radio Transmission Interference*
 - 38 *Twin Engine Readings*
 - 38 *Fuel Gauge*

39 Chapter 5: Navigation & Communication Equipment

- 39 Compass
- 39 Depth Finder
- 39 VHF Radio (If Equipped)
- 40 Radar (If Equipped)
- 40 Global Positioning System (GPS) (If Equipped)

41 Chapter 6: Plumbing

- 41 Bilge Pumps
 - 43 *Autofloat Switches*
- 44 Seawater Systems
 - 44 *Seacocks*
 - 44 *Seawater Strainers*
 - 45 *Raw Water Washdown (If Equipped)*

Hazard Boxes & Symbols

The hazard boxes and symbols shown below are used throughout this manual to call attention to potentially dangerous situations which could lead to either personal injury or product damage. **Read ALL warnings carefully and follow ALL safety instructions.**

 **DANGER!**
This box alerts you to immediate hazards which *WILL* cause severe personal injury or death if the warning is ignored.

 **WARNING!**
This box alerts you to hazards or unsafe practices which *COULD* result in severe personal injury or death if the warning is ignored.

 **CAUTION!**
This box alerts you to hazards or unsafe practices which *COULD* result in minor personal injury or cause product or property damage if the warning is ignored.

NOTICE
This box calls attention to installation, operation or maintenance information, which is important to proper operation but is *not* hazard related.

 FIRE HAZARD!	 EXPLOSION HAZARD!	 NO OPEN FLAME!	 ELECTRICAL HAZARD!	 HOT HAZARD!
---	--	---	--	--

 FALLING HAZARD!	 ROTATING PROPELLER HAZARD!	 RUN BILGE BLOWERS FOR 4 MINUTES!
--	---	--

DANGER
CARBON MONOXIDE
CO POISONING HAZARD!

Chapter 1: Welcome Aboard!

- This *Owner's Manual* provides specific information about your yacht.
- Additional information about safe operating practices, general boating regulations, and proper maintenance techniques is included in the *Cruiser & Yacht Owner's Manual Supplement*.
- The engine and accessories installed on your boat come with their own operation and maintenance manuals.
- Unless noted otherwise, **all** engine and accessory literature referred to in this *Owner's Manual* is included in your owner's packet.
- **Before** using your yacht, study this *Owner's Manual*, the *Cruiser & Yacht Owner's Manual Supplement*, and **all** engine and accessory literature carefully.
- Keep this *Owner's Manual*, the *Cruiser & Yacht Owner's Manual Supplement*, and **all** owner's packet literature, on your yacht in a secure, yet easy to get to place.

Dimensions and Tank Capacities

Overall Length	Bridge Clearance	Beam	Draft (Hull)	Draft (Maximum)	Fuel Capacity (gal.)	Freshwater Capacity (gal.)	Waste Holding Tank Capacity (gal.)
59' 4"	19' 7"	17' 2"	3' 4"	4' 11"	800	226	76

Layout View

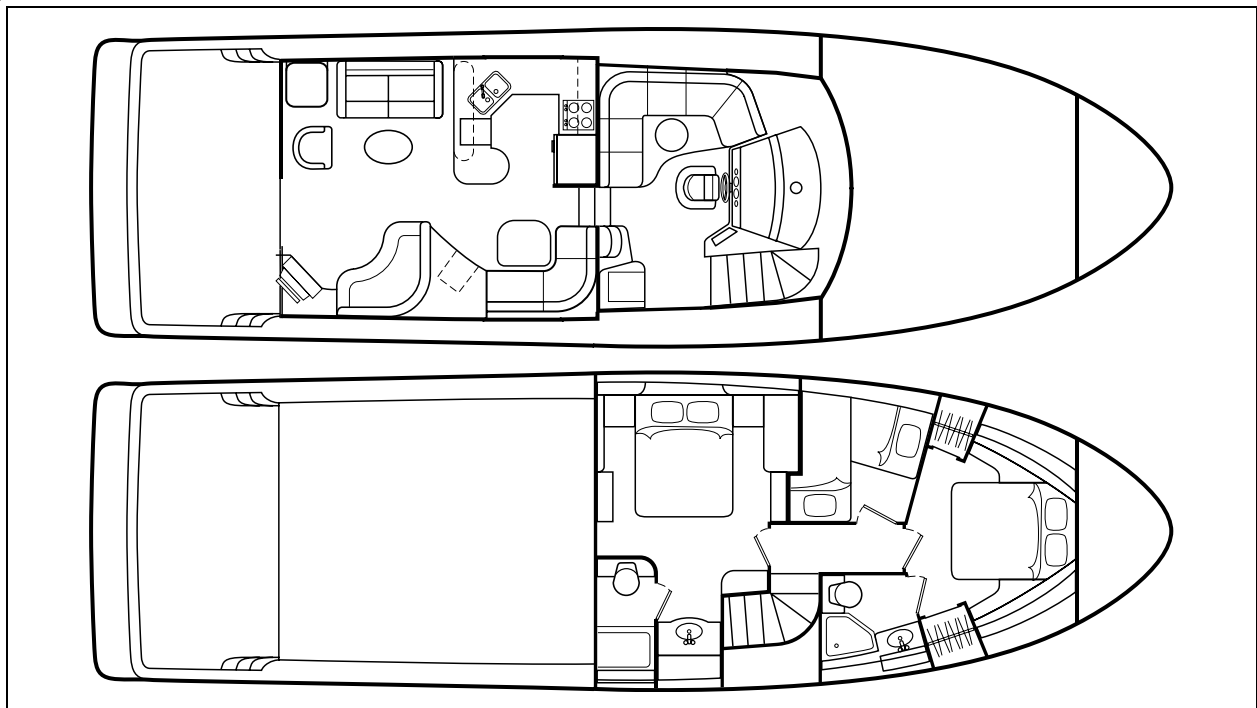

Dealer Service

- Ask your dealer to explain **all** systems **before** taking delivery of your yacht.
- Your dealer is your key to service.
- Contact your dealer if you have any questions or problems with your new yacht.
- If your dealer cannot help, call our customer service hotline: 360-403-2198 or send us a FAX: 360-403-1158.
- Buy replacement parts from any authorized Meridian dealer.

Warranty Information

- Meridian offers an Express Limited Transferable Warranty on each new Meridian purchased through an authorized Meridian dealer.
- A copy of the Express Limited Transferable Warranty was included in your owner's packet.
- If you did not receive a copy of the Express Limited Transferable Warranty, please contact your dealer or call 360-403-2198 for a copy.

Boating Experience

WARNING!

CONTROL HAZARD!

A qualified operator *must* be in control of the yacht at *all* times. *DO NOT* operate your yacht while under the influence of alcohol or drugs.

If this is your first yacht or if you are changing to a type of yacht you are *not* familiar with, obtain handling and operating experience *before* assuming command of the yacht.

Take one of the boating safety classes offered by the U.S. Power Squadrons or the U.S. Coast Guard Auxiliary. For more course information, including dates and locations of upcoming classes, contact the organizations directly:

- U.S. Power Squadrons: 1-888-FOR-USPS (1-888-367-8777) or on the Internet at: <http://www.usps.org>
- In Canada, for the CPS courses call 1-888-CPS-BOAT.
- U.S. Coast Guard Auxiliary: 1-800-368-5647 or on the Internet at: <http://www.cgaux.org>

Outside the United States, your selling dealer, national sailing federation or local boat club can advise you of local sea schools or competent instructors.

Engines & Accessories Guidelines

NOTICE

When storing your yacht please refer to your engine's operation and maintenance manuals.

- Your yacht's engines and accessories were selected to provide optimum performance and service.
- Installing different engines or other accessories may cause unwanted handling characteristics.
- Should you choose to install different engines or to add accessories that will affect the yacht's running trim, have an experienced marine technician perform a safety inspection and handling test before operating your yacht again.
- **Certain modifications to your yacht *will* result in the cancellation of your warranty protection. *Always* check with your dealer *before* making any modifications to your yacht.**

Engine & Accessories Literature

- The engines and accessories installed on your yacht come with their own operation and maintenance manuals.
- Read and understand these manuals *before* using the engines and accessories.
- Unless noted otherwise, *all* engine and accessory literature referred to in this *Owner's Manual* is included in your owner's packet.

Safety Standards

⚠ DANGER!



FALLING and ROTATING PROPELLER HAZARD!

NEVER allow anyone to ride on parts of the yacht *not* designed for such use.

- Sitting on seat backs, lounging on the forward deck, bow riding, gunwale riding or occupying the transom platform while underway is especially hazardous and will cause personal injury or death.

⚠ DANGER!



DANGER
CARBON MONOXIDE



ROTATING PROPELLER and CARBON MONOXIDE POISONING HAZARD!

- **NEVER** allow anyone to occupy, or hang from, the back deck or swim platform while the engine(s) are running.
- Teak surfing, dragging, or water skiing within 20 feet of a moving watercraft can be fatal.

⚠ DANGER!

PERSONAL SAFETY HAZARD!

ALWAYS secure the anchor and other loose objects before getting underway. The anchor and other items that are *not* properly secured can come loose when the yacht is moving and cause personal injury or death.

Your yacht's mechanical and electrical systems were designed to meet safety standards in effect at the time it was built. Some of these standards were mandated by law, all of them were designed to insure your safety, and the safety of other people, vessels and property.

In addition to this *Owner's Manual*, please read the *Cruiser & Yacht Owner's Manual Supplement* and all accessory instructions for important safety standards and hazard information.

Qualified Maintenance

⚠ WARNING!

To maintain the integrity and safety of your yacht, allow only qualified personnel to perform maintenance on, or in any way modify: The steering system, propulsion system, engine control system, fuel system, environmental control system, electrical system or navigational system.

- Failure to maintain your yacht's systems (listed in the warning above) as designed could violate the laws in your jurisdiction and could expose you and other people to the danger of bodily injury or accidental death.
- Follow the instructions provided in the *Cruiser & Yacht Owner's Manual Supplement*, this *Owner's Manual*, the engine owner's manual and all accessory literature.

Structural Limitations

The command bridge is designed to be lightweight for proper yacht balance. The load limit for this platform is 30 pounds per square foot, evenly distributed.

Special Care For Moored Boats

NOTICE

- To help seal the hull bottom and reduce the possibility of gelcoat blistering on moored yachts, apply an epoxy barrier coating. The barrier coating should be covered with several coats of anti-fouling paint.
- Many states regulate the chemical content of bottom paints in order to meet environmental standards. Check with your local dealer about recommended bottom paints, and about the laws in effect in your area.

- Whether moored in saltwater or freshwater, your yacht *will* collect marine growth on its hull bottom.
- This *will* detract from the yacht's beauty, greatly affect its performance and may damage the gelcoat.
- There are two methods of slowing marine growth:
 1. Periodically haul the yacht out of the water and scrub the hull bottom with a bristle brush and a solution of soap and water.
 2. Occasionally re-paint the hull below the waterline with a good grade of anti-fouling paint.

Sacrificial Anodes (Zincs)

NOTICE

Do not paint between the zinc and the metal surface it contacts and do not paint over the zincs.

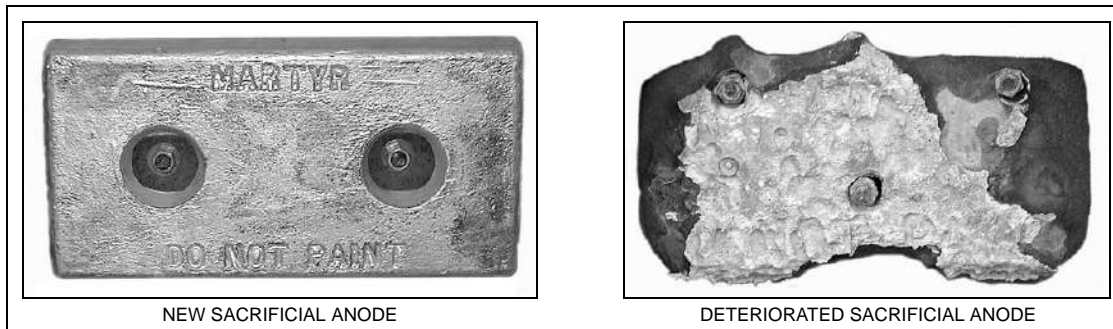

Your yacht features sacrificial anodes (zincs) to protect underwater metal parts from excessive deterioration. Check the zincs regularly and replace them if they have deteriorated more than 70%.

There are many factors that affect the rate at which the zincs deteriorate, including:

- Water temperature
- Salinity
- Water pollution

Stray electrical current from the yacht or dock may cause complete deterioration in just a few weeks. If there is rapid zinc deterioration, measure the electrolytic corrosion around your yacht with a corrosion test meter. If the zincs are *not* bonded correctly, they *will not* provide protection.

Boat Lifting



WARNING!

PERSONAL INJURY and /or PRODUCT OR PROPERTY DAMAGE HAZARD!

- Lifting slings *may* slip on the hull.
- Avoid serious injury or death by securing the lifting slings together before lifting.



WARNING!

PERSONAL INJURY and /or PRODUCT OR PROPERTY DAMAGE HAZARD!

- **NEVER** lift the yacht using the bow and stern eyes.



CAUTION!

PRODUCT or PROPERTY DAMAGE HAZARD!

- When lifting any yacht, *always* use a spreader bar. The spreader bar *must* be equal to the width of the yacht at each lifting point.

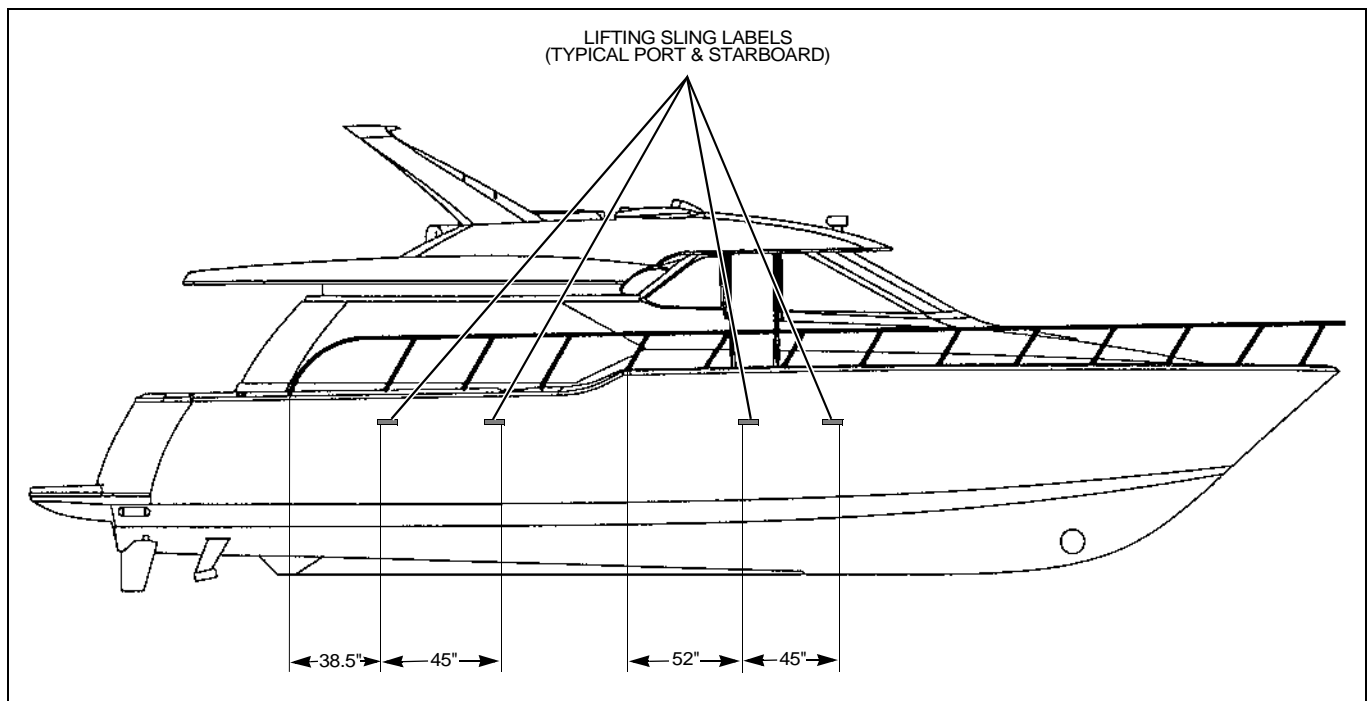

- **Always** follow the lift equipment's instructions and requirements.
- Water in the bilge can shift and change the balance of the load.
- If water is present in the bilge, pump or drain the water out of the bilge areas **before** lifting your yacht.
- When lifting your yacht, **always** position the lifting slings at the port and starboard, lifting sling label positions, as shown in the illustration on the right.

Carbon Monoxide (CO)

⚠ DANGER!	
	<ul style="list-style-type: none"> • Carbon monoxide gas (CO) is colorless, odorless, tasteless, and extremely dangerous. • <i>All</i> engines, generators, and fuel burning appliances produce CO as exhaust. • Prolonged exposure to low concentrations or very quick exposure to high concentrations <i>will</i> cause BRAIN DAMAGE or DEATH. • Teak surfing, dragging, or water skiing within 20 feet of a moving watercraft can be fatal.

Facts about CO

- CO poisoning causes a significant number of boating deaths each year.
- Called the "silent killer", CO is an extremely toxic, colorless, odorless and tasteless gas.
- CO can harm or even kill you inside or outside your yacht.
- CO can affect you whether you're underway, moored, or anchored.
- CO symptoms are similar to seasickness or alcohol intoxication.
- CO can make you sick in seconds. In high enough concentrations, even a few breaths can be fatal.
- Breathing CO blocks the ability of your blood to carry oxygen.
- The effects are cumulative, even low levels of exposure can result in injury or death.

Factors That Increase the Effects of CO Poisoning

- Age
- Smokers or people exposed to high concentrations of cigarette smoke
- Consumption of alcohol
- Lung disorders
- Heart problems
- Pregnancy

Where and How CO Can Accumulate

Stationary Conditions That Increase CO Accumulations Include:

- A. Using engine, generator, or other fuel burning device when yacht is moored in a confined space.

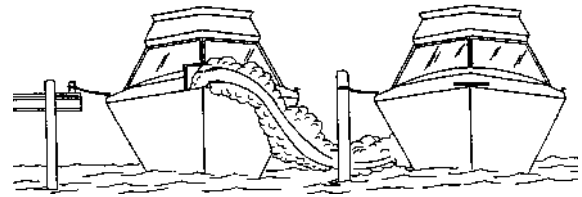
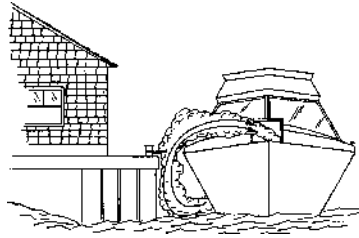

- B. Mooring too close to another boat that is using its engine, generator, or other fuel burning device.

To correct stationary situations A and/or B:

- **Close all** windows, portlights and hatches.
- If possible, move your yacht away from source of CO.

Running Conditions That Increase CO Accumulations Include:

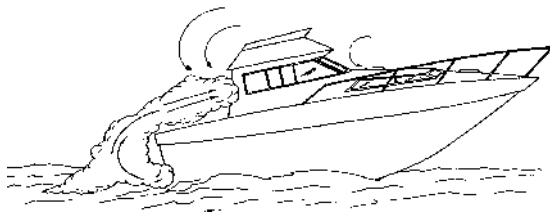

- C. Running yacht with trim angle of bow too high.

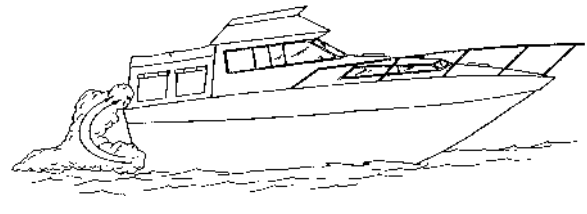

- D. Running yacht without through ventilation (station wagon effect).

To correct running situations C and/or D:

- Trim bow down.
- **Open** windows and canvas.
- When possible, run yacht so that prevailing winds help dissipate exhaust.

How to Protect Yourself and Others From CO

- Know where and how CO may accumulate in and around your yacht (see above).
- Maintain fresh air circulation throughout the yacht at **all** times.
- Know where your engine and generator exhaust outlets are located and keep everyone away from these areas.
- **Never** sit on, or hang onto, the back deck or swim platform while the engine(s) are running.
- **Never** enter the areas under swim platforms where exhaust outlets are located.
- Although CO can be present without the smell of exhaust fumes, if exhaust fumes are detected on the yacht, take immediate action to dissipate these fumes.
- Treat symptoms of seasickness as possible CO poisoning. Get the person into fresh air **immediately**. Seek medical attention—unless you're sure it's **not** CO.
- Install and maintain CO alarms inside your yacht. **Do not** ignore any alarm. Replace alarms as recommended by the alarm manufacturer.
- Follow the checklists provided on the next page.
- Get a Vessel Safety Check.

For information on how to get a free VESSEL SAFETY CHECK, visit www.vesselsafetycheck.org or contact your local U.S. Coast Guard Auxiliary or United States Power Squadrons®.

- U.S. Coast Guard Auxiliary: 1-800-368-5647 or on the Internet at: <http://www.cgaux.org>
- U.S. Power Squadrons: 1-888-FOR-USPS (1-888-367-8777) or on the Internet at: <http://www.usps.org>

Trip Checklist

- Make sure you know where the exhaust outlets are located on your yacht.
- Educate *all* passengers about the symptoms of CO poisoning and where CO may accumulate.
- When docked, or rafted with another boat, be aware of exhaust emissions from the other boat.
- Confirm that water flows from the exhaust outlet when the engines and generator are started.
- Listen for any change in exhaust sound, which could indicate an exhaust component failure.
- Test the operation of each CO alarm by pressing the test button.

Monthly Checklist



- Make sure *all* exhaust clamps are in place and secure.
- Look for exhaust leaking from exhaust system components. Signs include rust and/or black streaking, water leaks, or corroded or cracked fittings.
- Inspect rubber exhaust hoses for burned, cracked, or deteriorated sections. *All* rubber hoses should be pliable and free of kinks.

Annual Checklist

Have a Qualified Marine Technician:

- Replace exhaust hoses if cracking, charring, or deterioration is found.
- Ensure that your engines and generators are properly tuned, and well maintained.
- Inspect each water pump impeller and the water pump housing. Replace if worn. Make sure cooling systems are in working condition.
- Inspect *all* metal exhaust parts for cracking, rusting, leaking, or loosening and check the cylinder head gasket, exhaust manifold, water injection elbow, and the threaded adapter nipple between the manifold and the elbow.
- Clean, inspect, and confirm proper operation of the generator cooling water anti-siphon valve (if equipped).

Carbon Monoxide Alarm System

 DANGER!	
	<p><i>CARBON MONOXIDE POISONING HAZARD!</i></p> <ul style="list-style-type: none"> • The house battery switch must be in the <i>On</i> position for the CO Monitors to work. • If your yacht will be unattended for an extended period of time, turn <i>Off</i> the house battery or the CO Monitors <i>will</i> drain the house battery.

NOTICE
The stereo memory and CO monitor(s) place a small, but constant drain on the battery. If your yacht will be unattended for an extended amount of time, plug into shore power with the battery charger turned <i>On</i> .

- *Do not* disconnect the alarm system.
- Read and understand the manufacturer's instructions for your CO alarm system. If you did *not* receive an instruction manual, call (800) 383-0269 and one will be mailed to you.

If your yacht is *not* equipped with a carbon monoxide alarm, consider purchasing one from your dealer or marine supply store.

More Information

For more information about how you can prevent carbon monoxide poisoning on recreational boats and other ways to boat more safely, contact:

United States Coast Guard

Office of Boating Safety (G-OPB-3)

2100 Second Street SW

Washington, DC 20593

www.uscgboating.org

1-800-368-5647

National Marine Manufacturers
Association (NMMA)

200 East Randolph Drive

Suite 5100

Chicago, IL 60601-9301

www.nmma.org

312-946-6200

American Boat & Yacht Council, Inc.
(ABYC)

3069 Solomon's Island Road

Edgewater, MD 21037-1416

www.abycinc.org

410-956-1050

For information on how to get a free VESSEL SAFETY CHECK, visit www.vesselsafetycheck.org or contact your local U.S. Coast Guard Auxiliary or United States Power Squadrons®.

- U.S. Coast Guard Auxiliary: 1-800-368-5647 or on the Internet at: <http://www.cgaux.org>
- U.S. Power Squadrons: 1-888-FOR-USPS (1-888-367-8777) or on the Internet at: <http://www.usps.org>

Chapter 2: Locations

Exterior Views

Hull Views

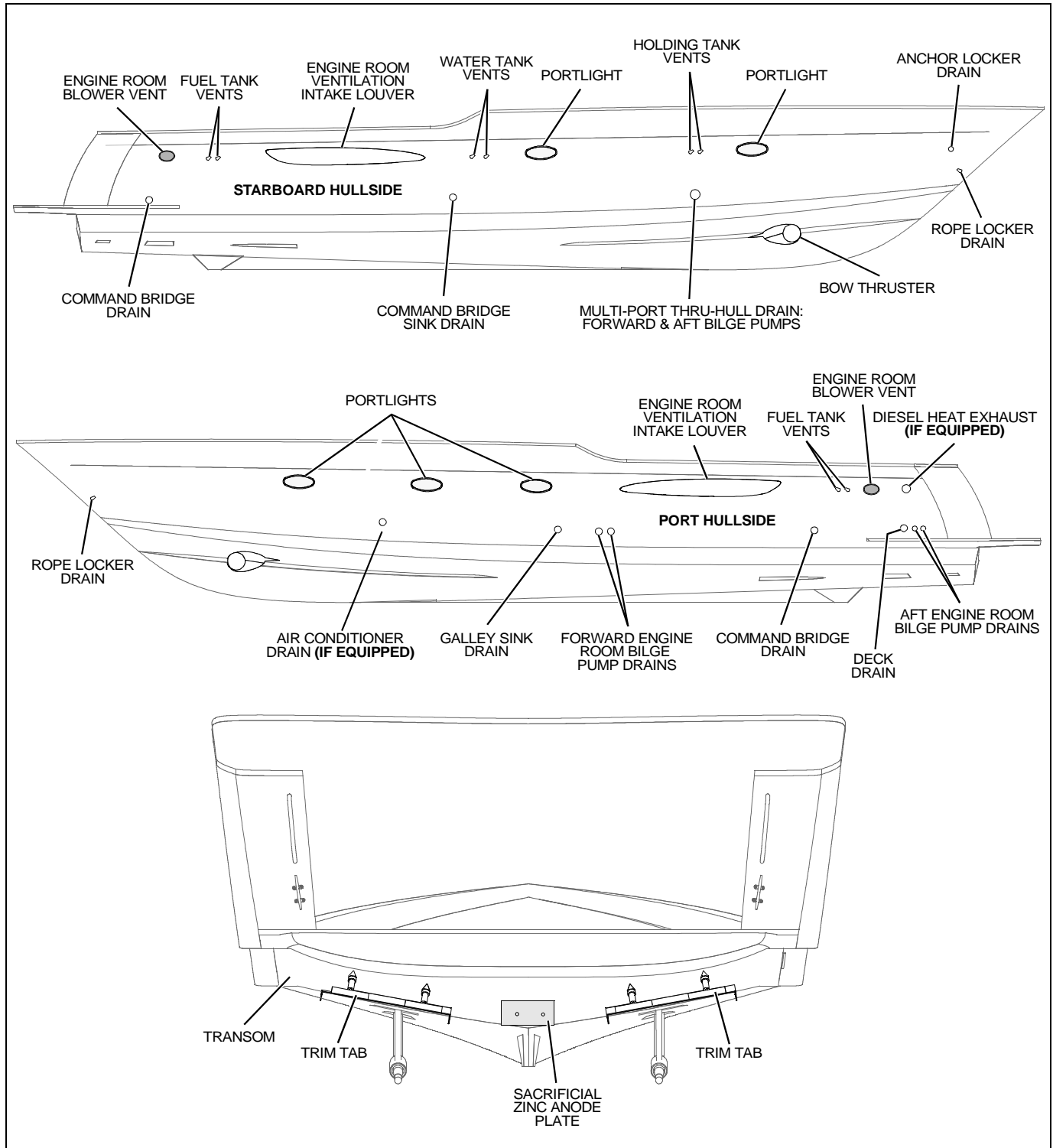

Deck Views

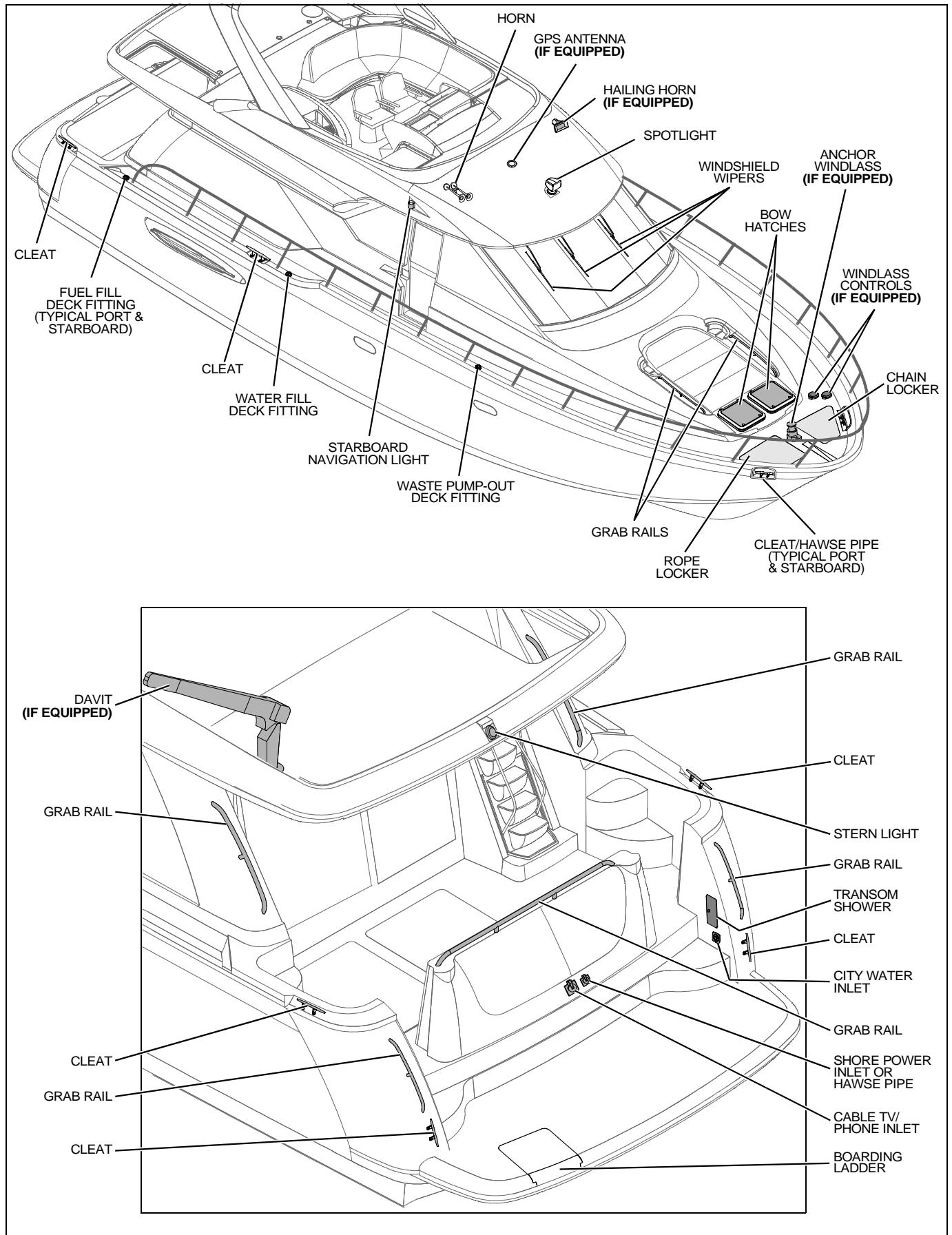

Helm Stations

Pilothouse Helm Station

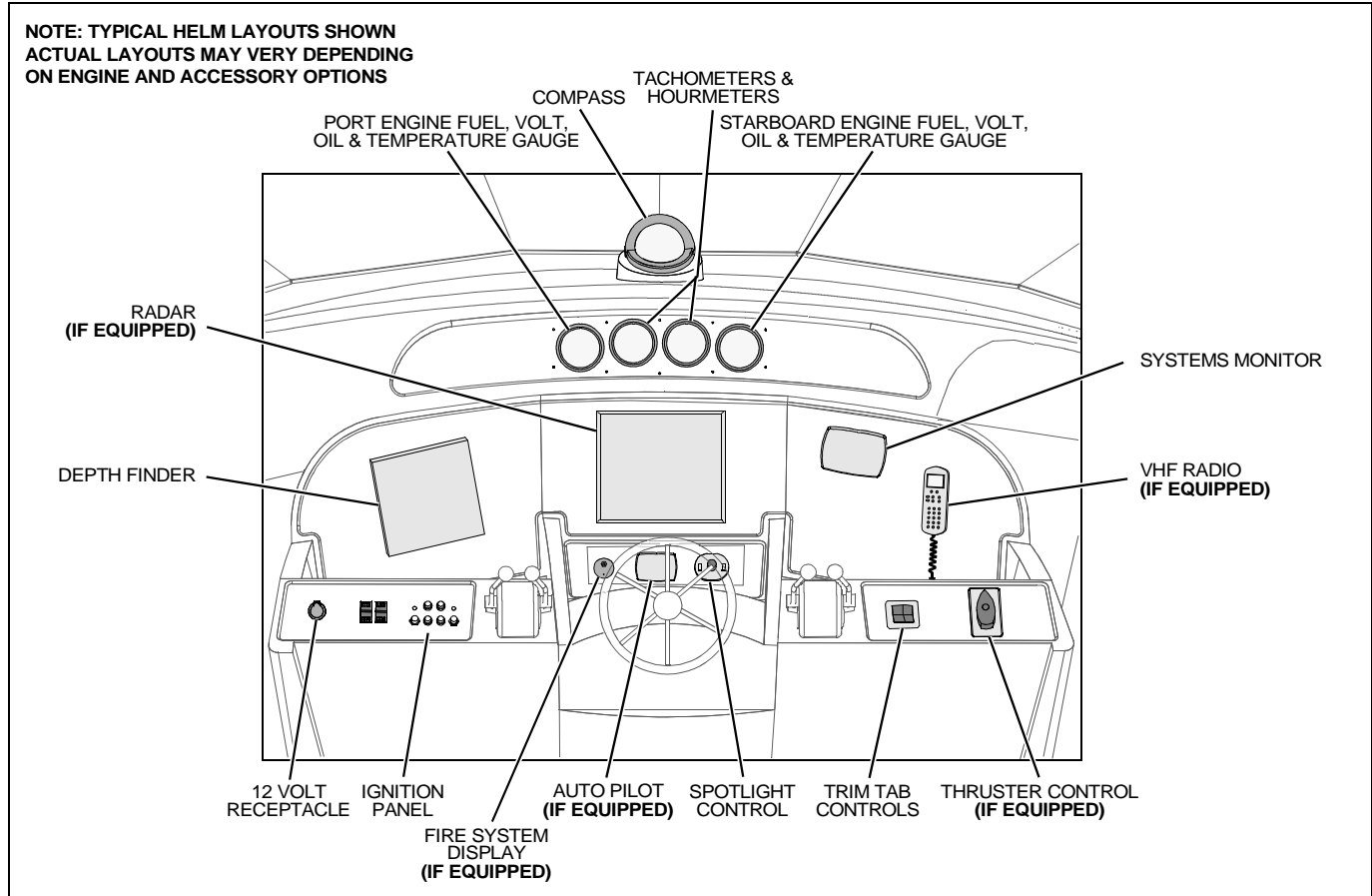

Command Bridge Helm Station

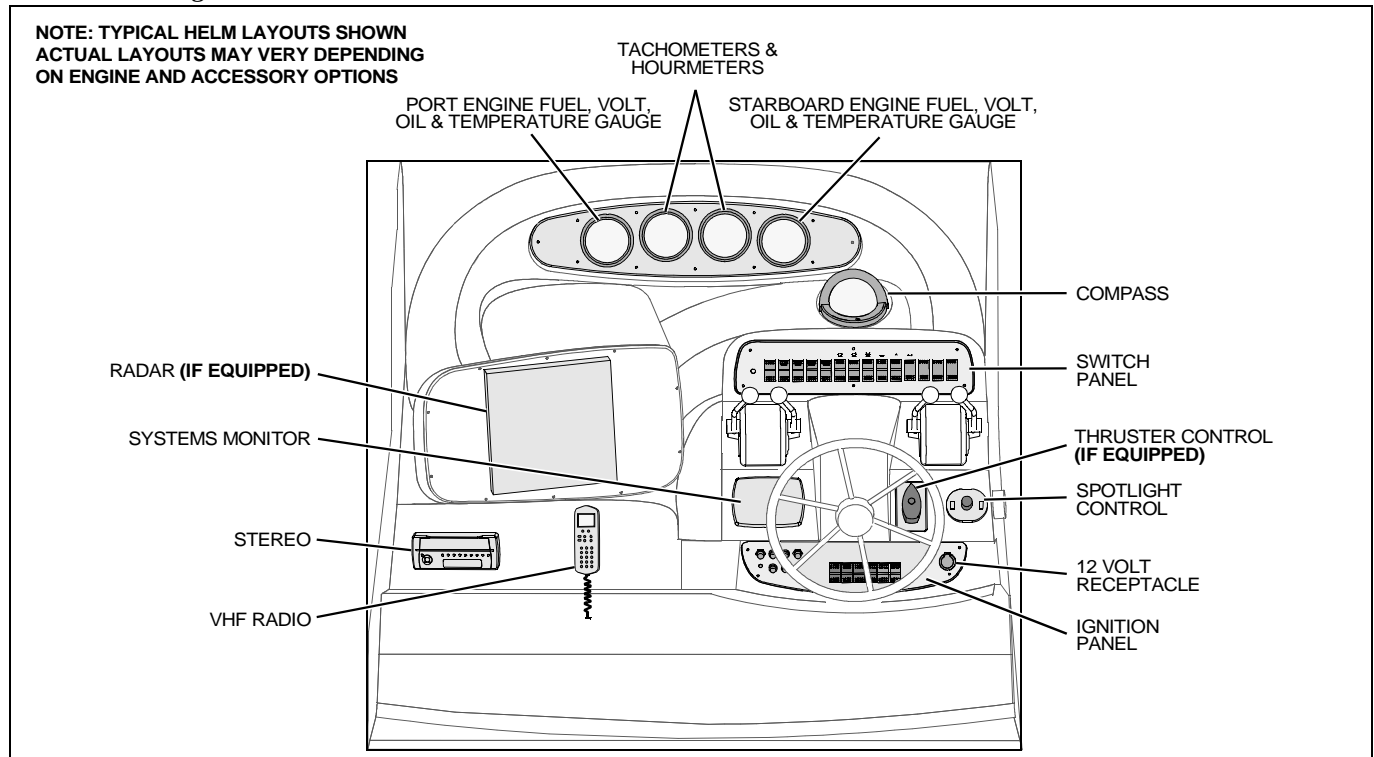

Component Locations

12-Volt Accessory Outlet (2):

- Located on the pilothouse dash.

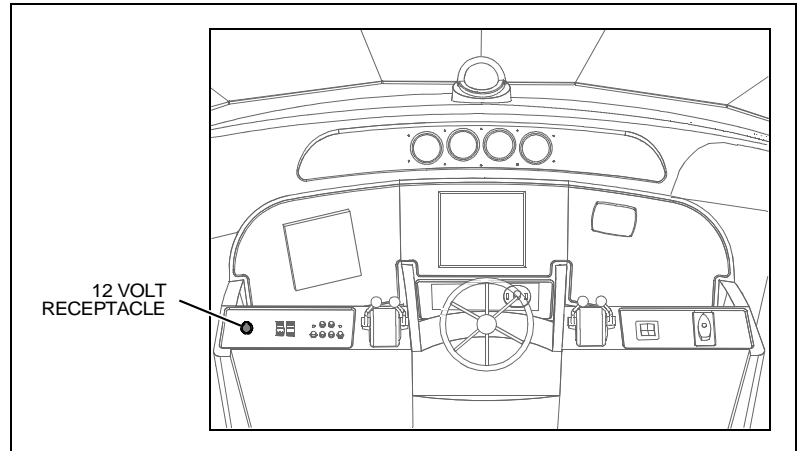

- Located on the command bridge dash.

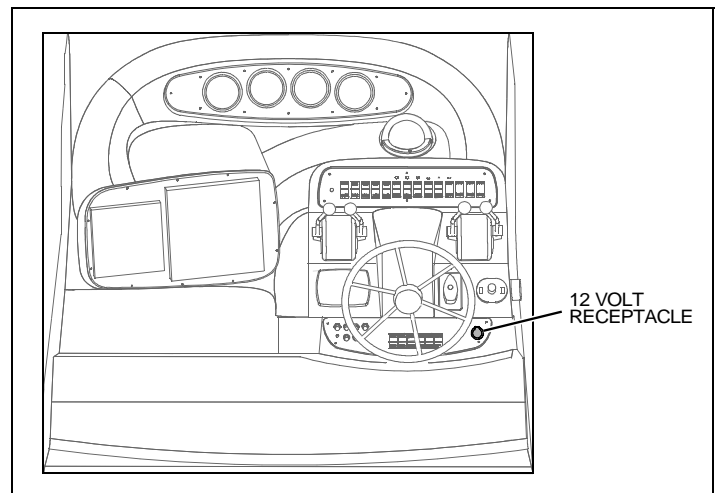

Air Conditioner Seawater Intake Seacock:

- Located in the forward engine room.
- Access the engine room by lifting up the command bridge stairs.

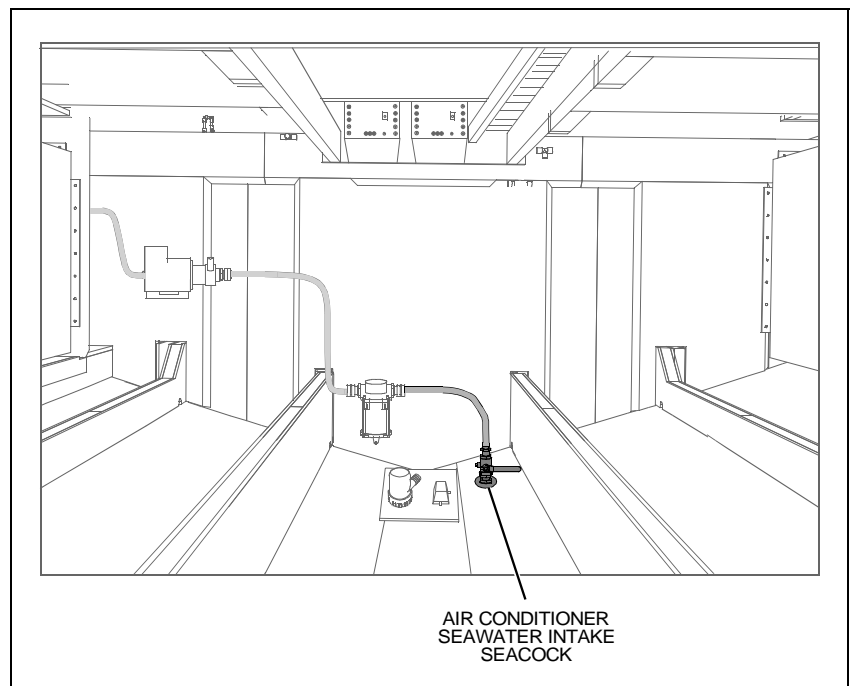

Air Conditioner Unit - V-berth:

- Located in the forward storage locker under the V-berth mattress.

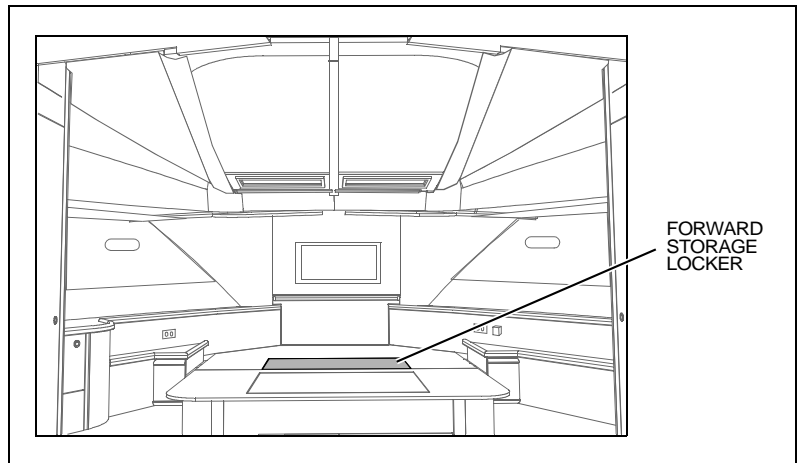

Air Conditioner Unit - Aft Salon:

- Located in the aft salon cabinet.

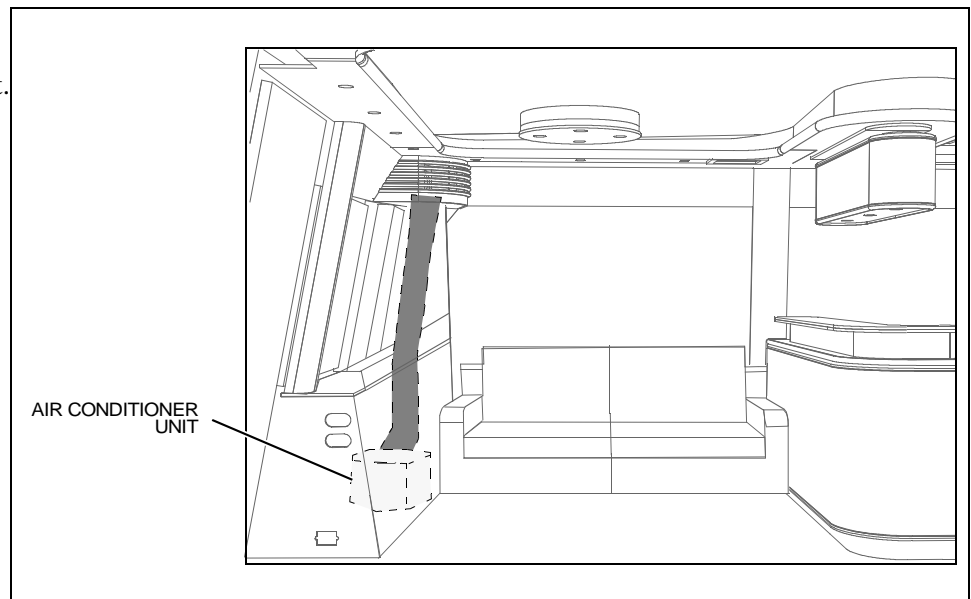

Air Conditioner Unit - Forward Salon:

- Located under the forward lounge seat cushion.

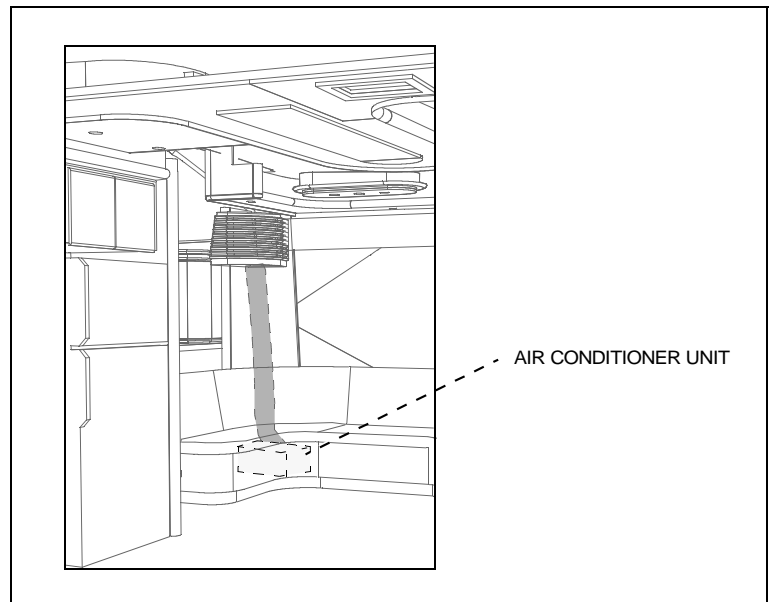

**Air Conditioner Unit -
Master Stateroom:**

- Located behind the master stateroom entertainment cabinet.
- Access is through the access panel in the lower cabinet doors.

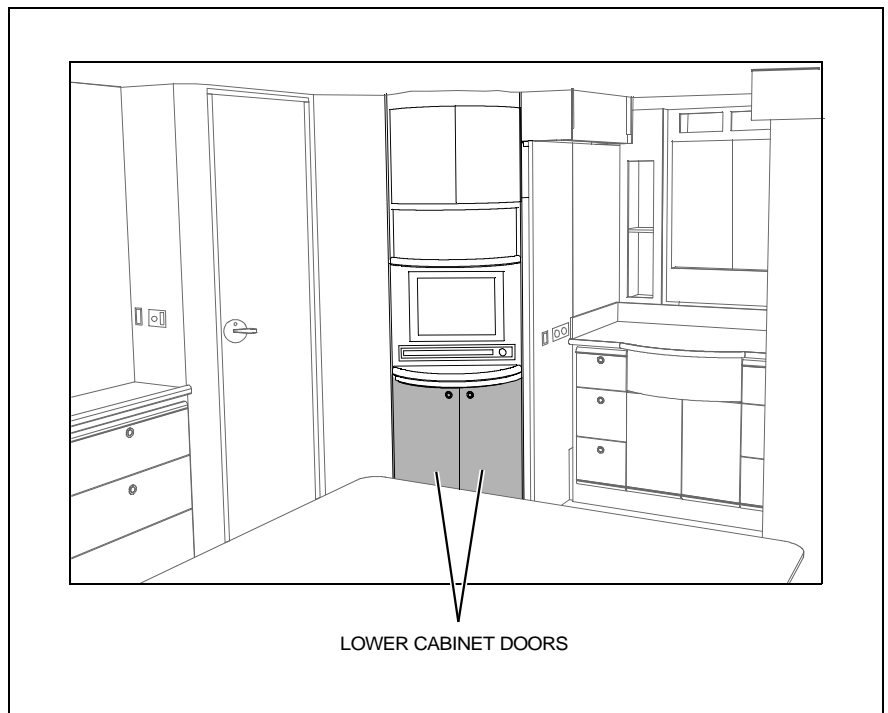
**Air Conditioner Unit - Pilothouse:**

- Located under the forward port side lounge seat cushion.

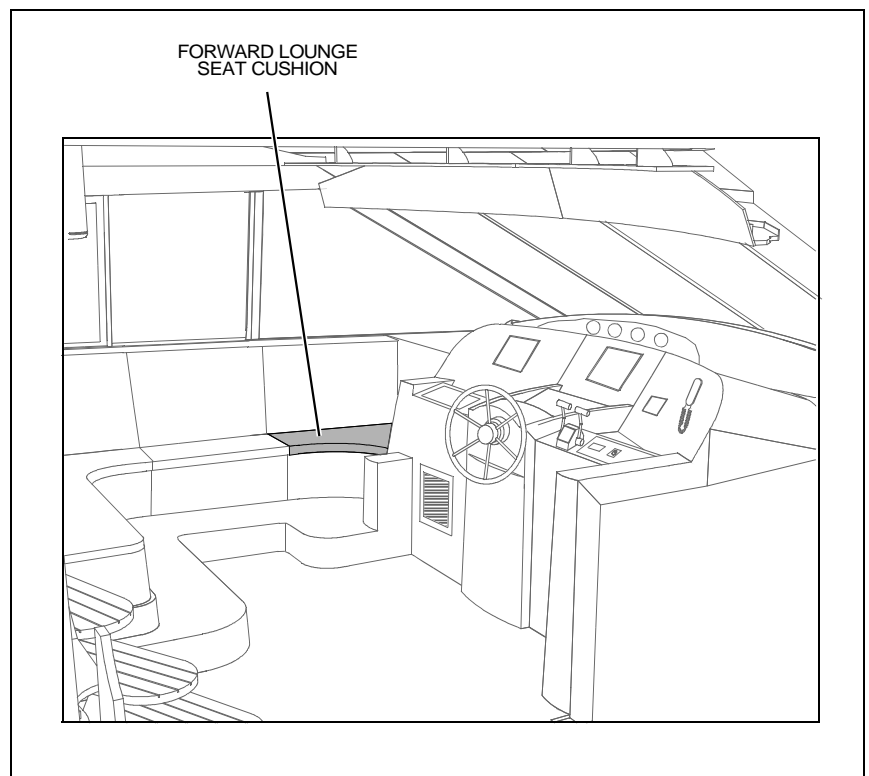

Batteries:

- Located in the cockpit machinery room.
- Access the machinery room through the cockpit floor hatches.

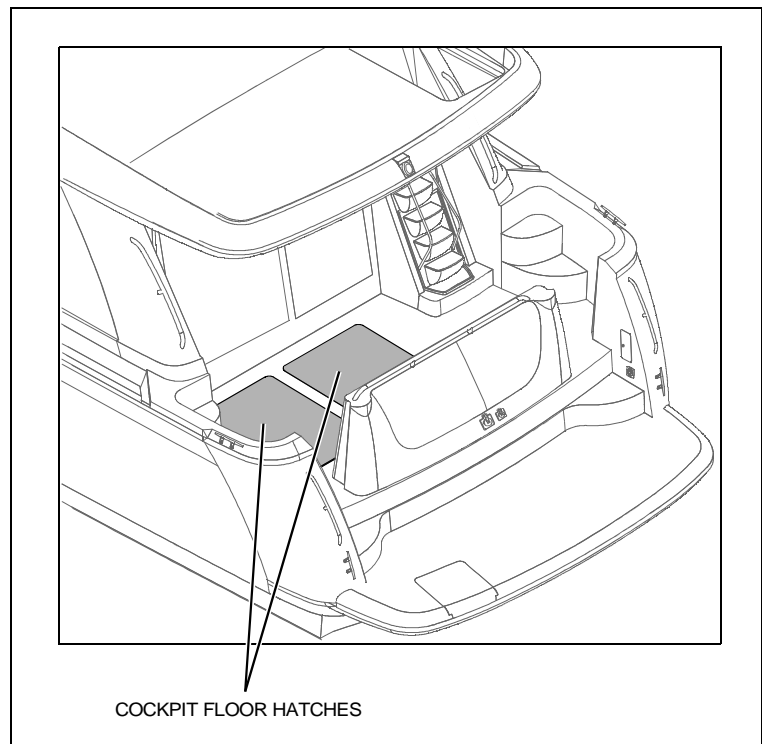
**Battery Charger:**

- Located in the engine room on the aft wall.
- Access the engine room by lifting up the command bridge stairs.

Battery Charger Inverter:

- Located in the engine room on the aft wall.

Battery Equalizer:

- Located in the engine room on the aft wall.

Battery Switches:

- Located in the engine room on the aft wall.

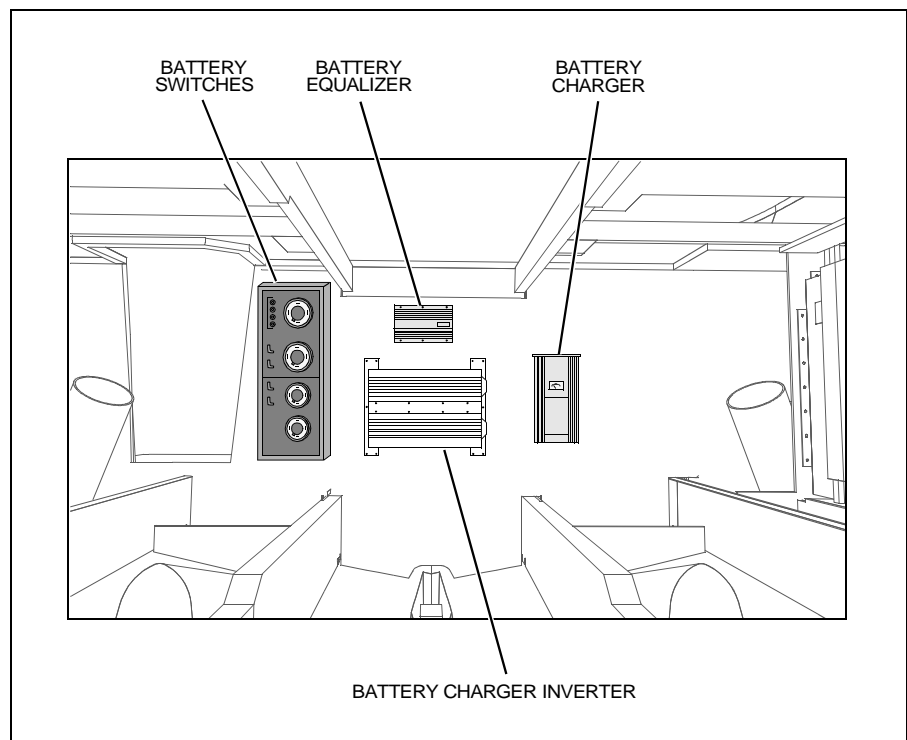

Bilge Pump and Float Switch - Aft:

- Located in the starboard cockpit floor hatch, aft of the access ladder.

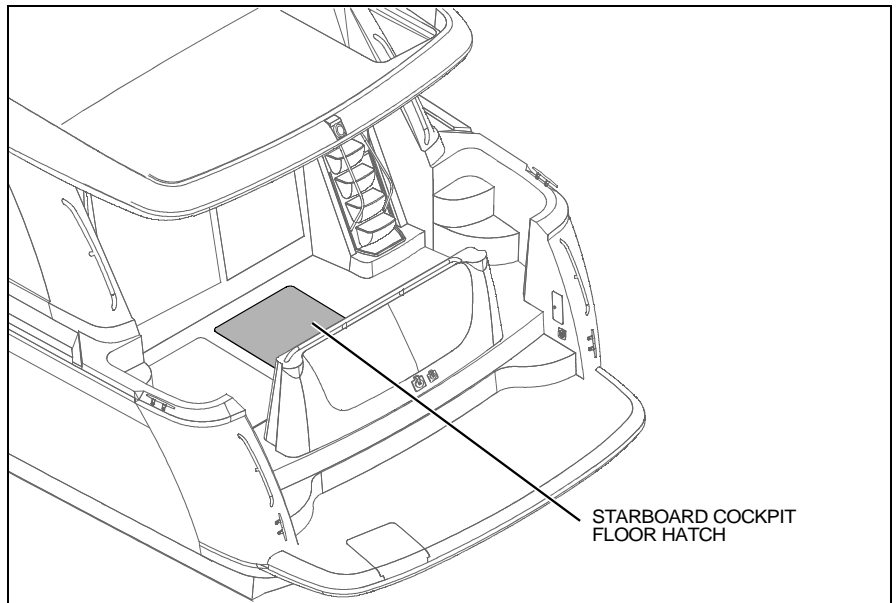
**Bilge Pump and Float Switch - Mid-Aft:**

- Located in the aft engine room.
- Access the engine room by lifting up the command bridge stairs.

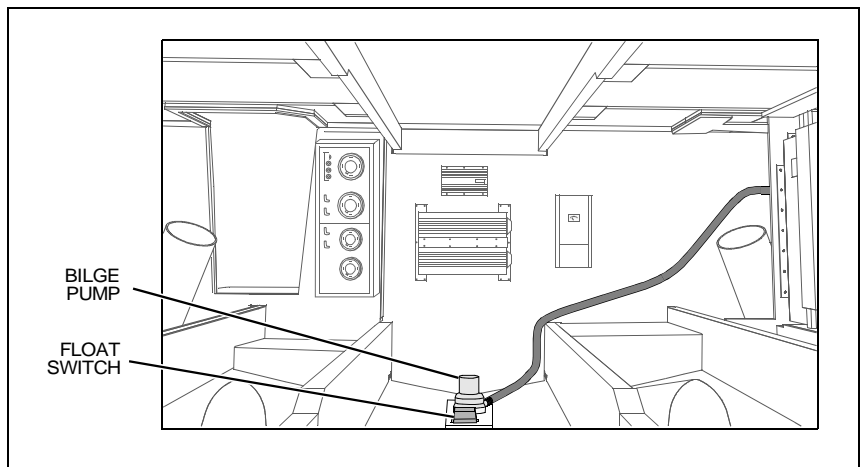

Bilge Pump and Float Switch - Mid-Forward:

- Located in the forward engine room.
- Access the engine room by lifting up the command bridge stairs.

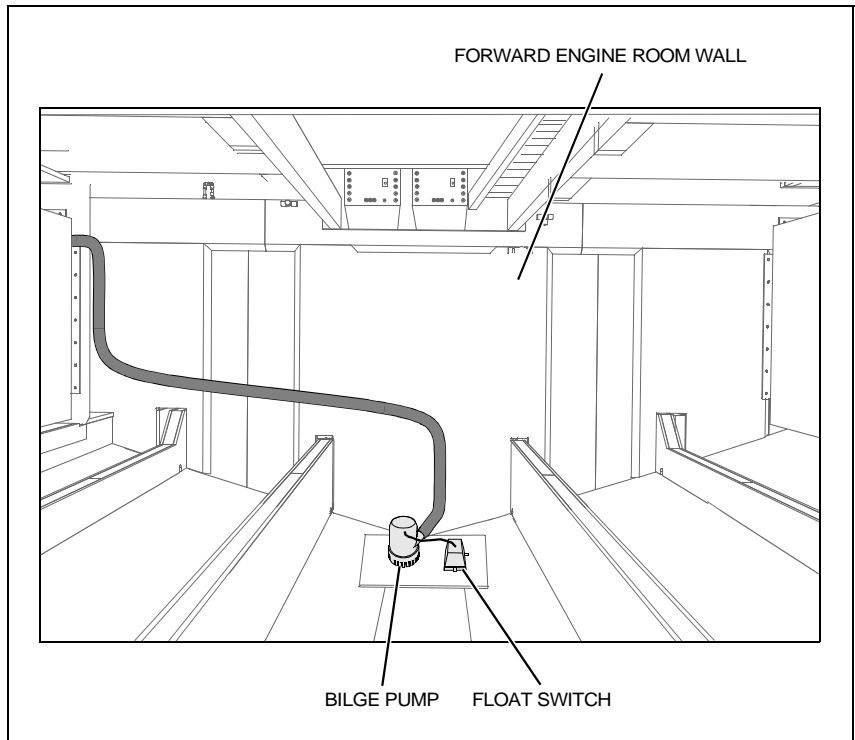

Bilge Pump and Float Switch - Forward:

- Located under the aft hallway floor hatch.

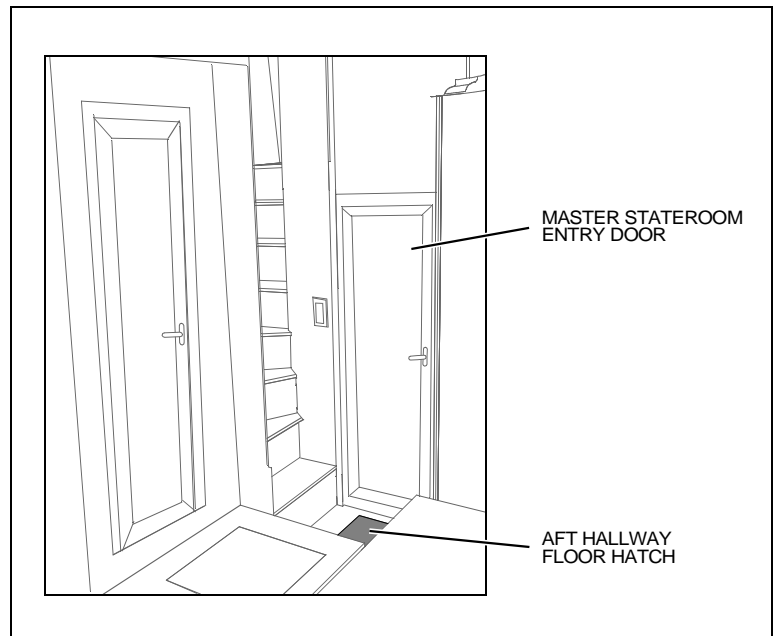

DC Circuit Breakers:

- Located inside the cabinet on the port side wall of the pilothouse staircase.

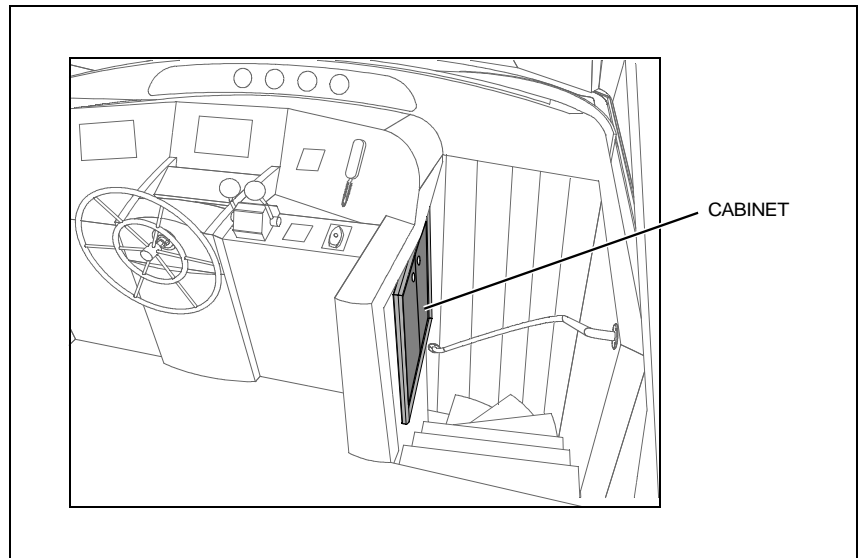
**Depth Sounder Thru-hull Transducer:**

- Located in the forward engine room.
- Access the engine room by lifting up the command bridge stairs.

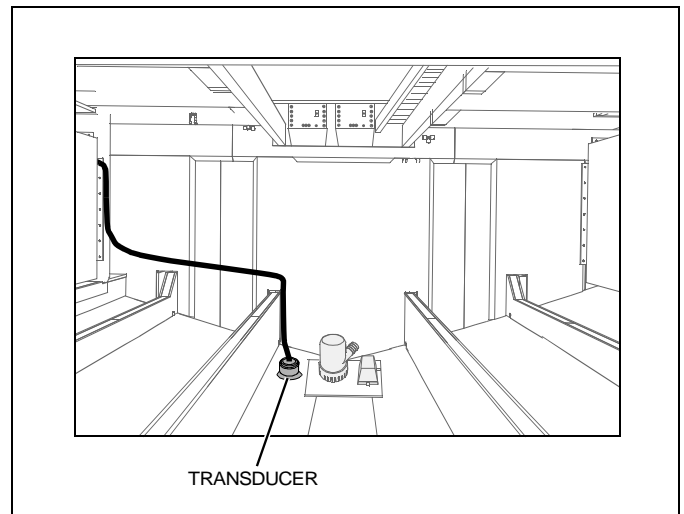
**Engine Circuit Breaker:**

- Located on each engine.

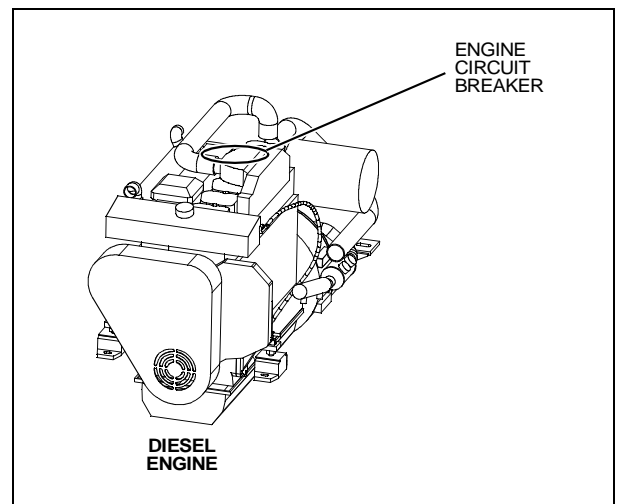

Engine Cooling System Seawater Intake Seacocks:

- Located in the engine room, aft of each engine.

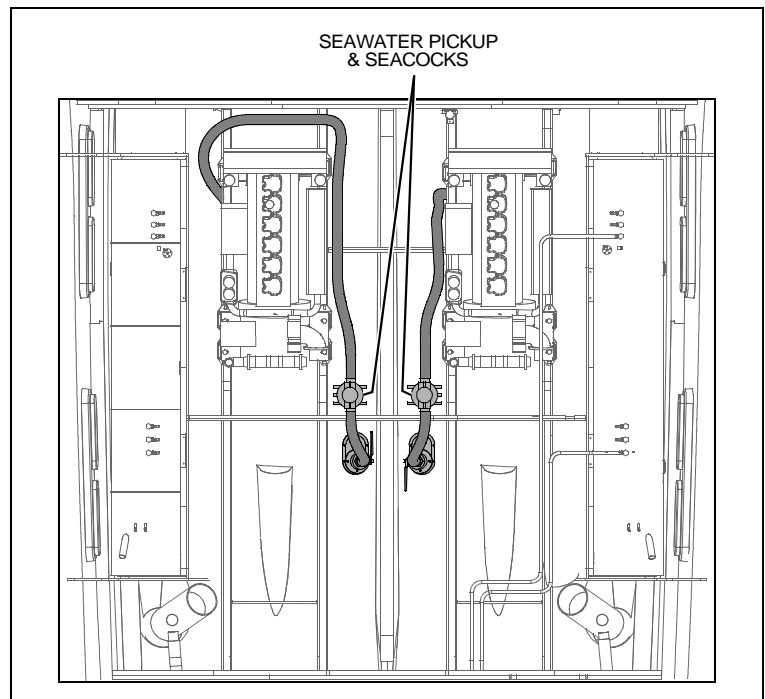

Fire Suppression Tank - Aft:

- Located in the cockpit machinery room, forward of the generator.
- Access the machinery room through the starboard cockpit floor hatch.

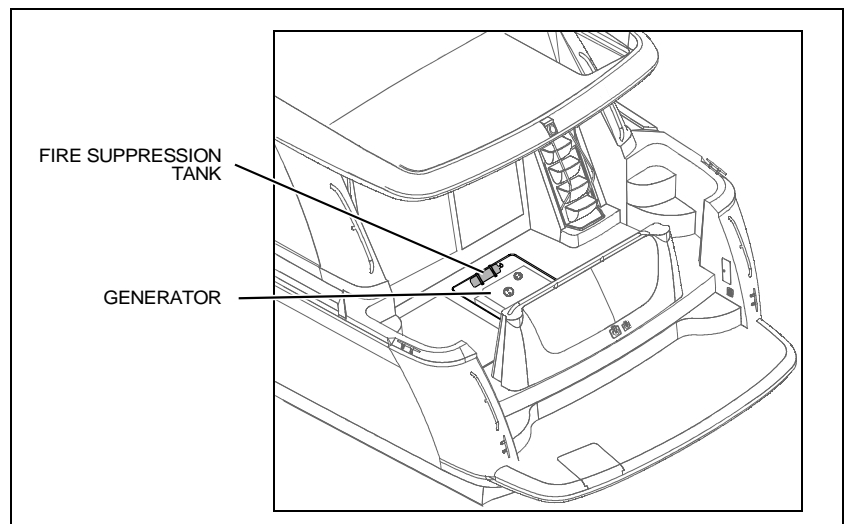

Fire Suppression Tank - Forward:

- Located in the engine room, on the forward wall.
- Access the engine room by lifting up the command bridge stairs.

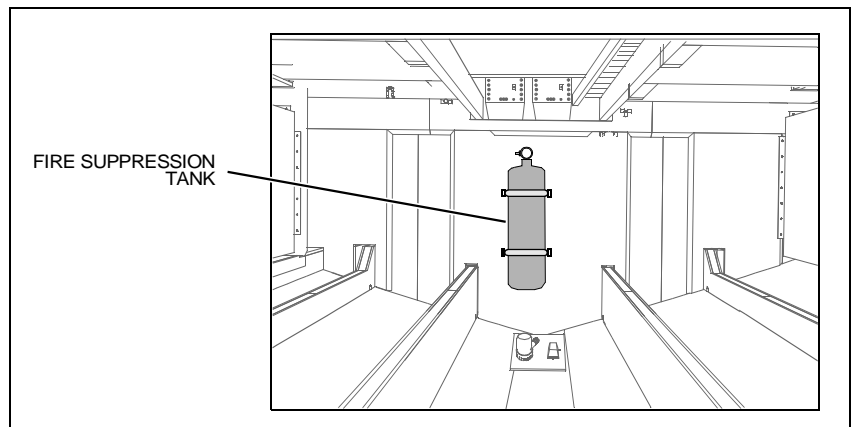

Freshwater Fill:

- Located on the starboard deck trail.

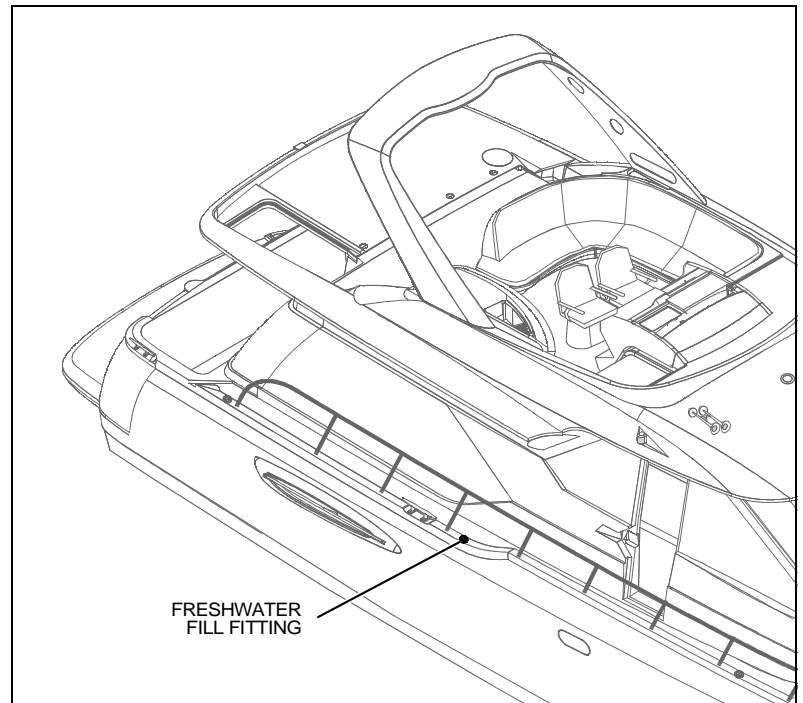
**Freshwater Tanks:**

- Located in the master stateroom.
- Access the sender by pulling the starboard bottom drawer of the aft dresser out.
- Access the tank fittings by pulling out the cabinet in the master stateroom head.

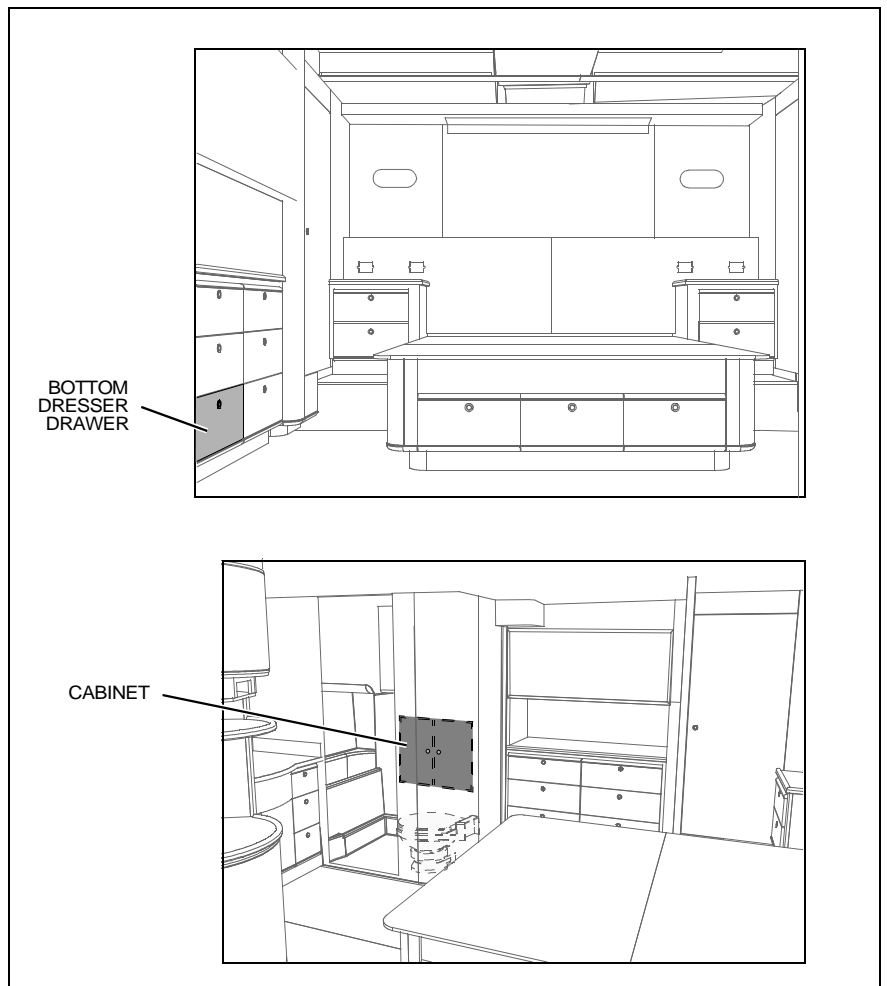

Fuel Fills:

- Located on the port and starboard deck trails.

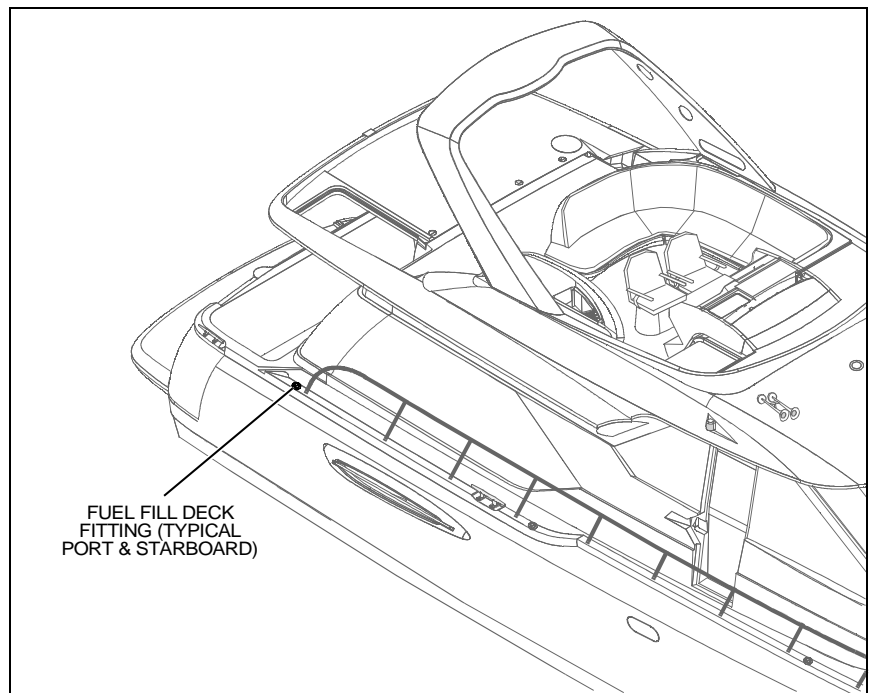
**Fuel Tanks:**

- Located on each side of the engine room.
- Access the engine room by lifting up the command bridge stairs.

Generator:

- Located in the aft cockpit machinery room.
- Access the machinery room through the starboard aft cockpit floor hatch.

Generator Control Panel:

- Located on the starboard side of the pilothouse, in the electrical cabinet.

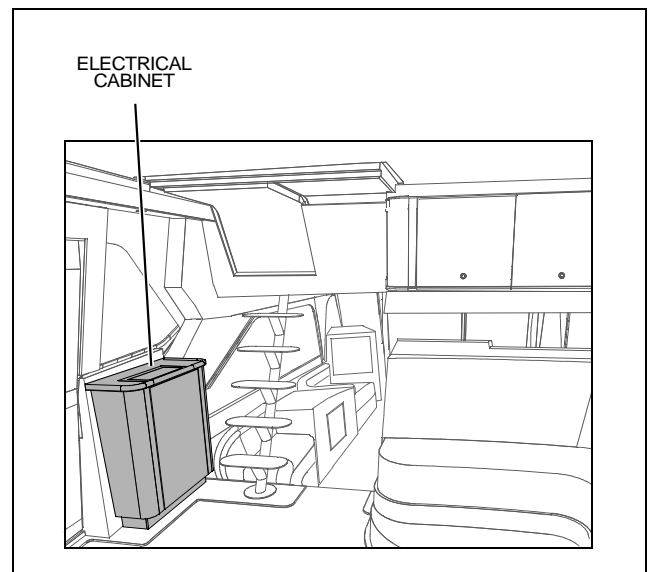

Generator Seawater Pickup Seacock:

- Located in the aft cockpit machinery room, aft of the generator muffler.
- Access the machinery room through the starboard aft cockpit floor hatch.

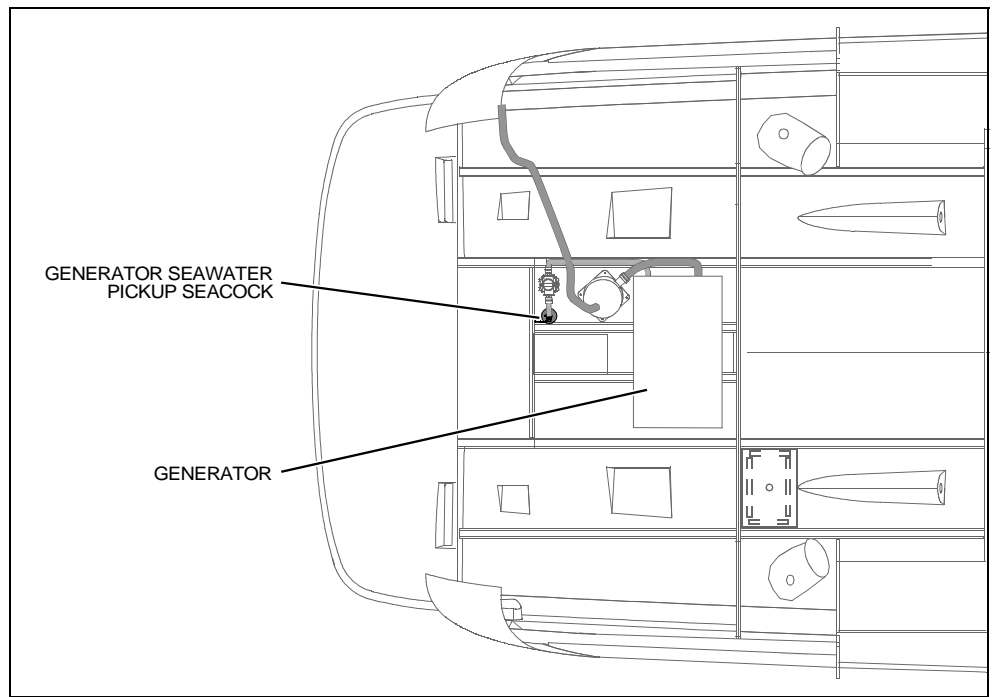

Hydraulic Steering Fluid Reservoir:

- Located on the steering wheel.

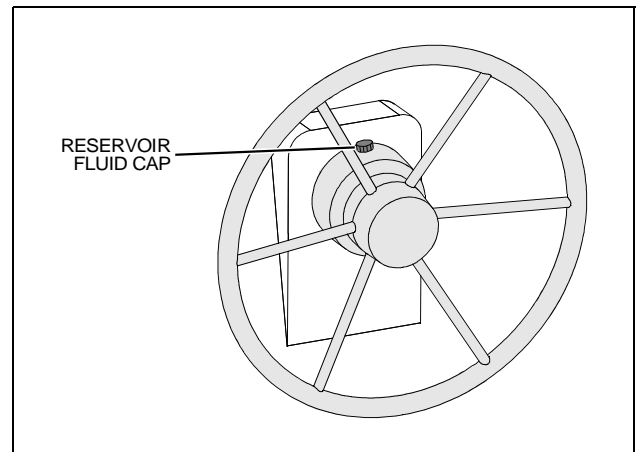

Macerator Underwater Discharge Seacock (If Equipped):

- Located under the forward hallway floor hatch.

Marine Head (Electric) Seawater Intake Seacock (If Equipped):

- Located under the forward hallway floor hatch.

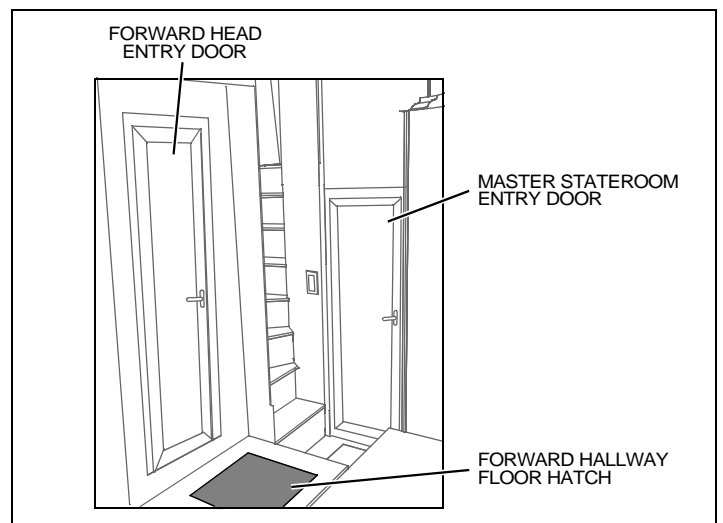

Aft Shower Sump Pump:

- Located in the master stateroom.
- Access the aft sump pump by pulling out the cabinet on the aft wall in the head.

Forward Shower Sump Pump:

- Located under the forward hallway floor hatch.

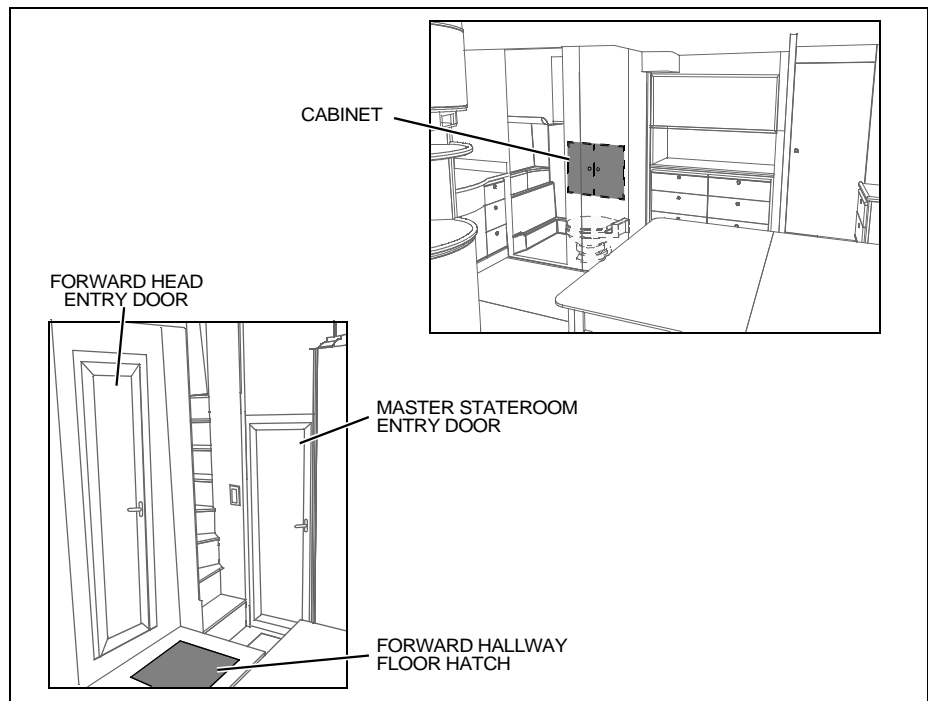
**Wall Vacuum Unit:**

- Located in the salon, under the aft lounge seat cushion.

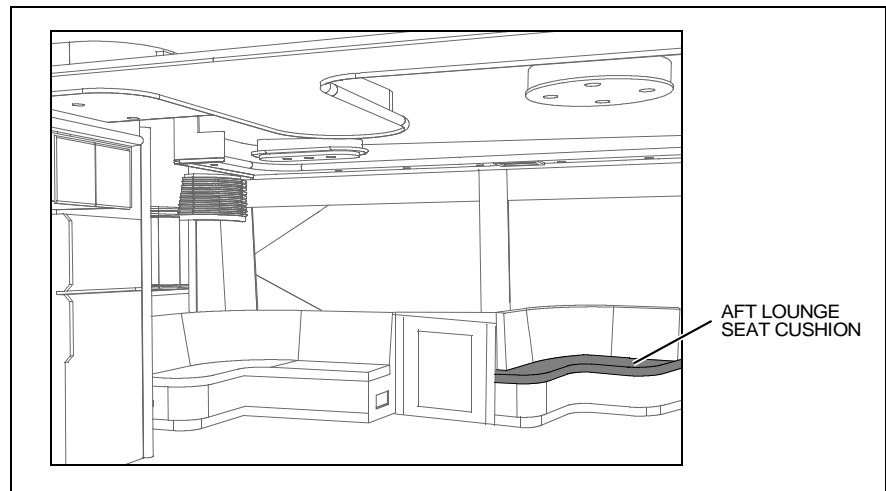

Waste Holding Tank:

- Located under the forward hallway floor hatch.

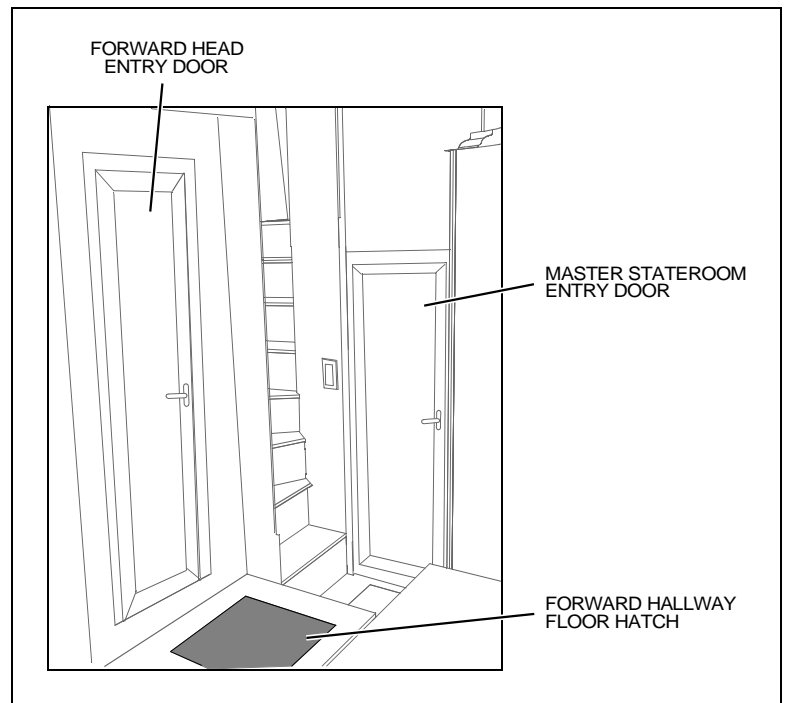
**Water Heater:**

- Located in the master stateroom.
- Access the water heater by pulling out the cabinet on the aft wall in the head.

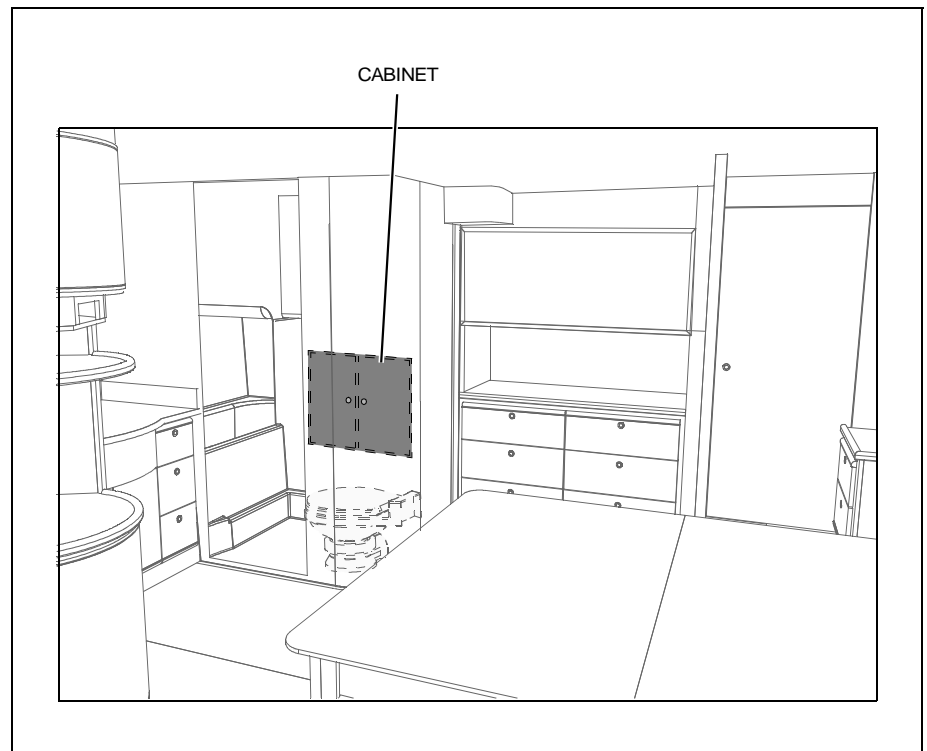

Water Pump:

- Located in the forward engine room.
- Access the engine room by lifting up the command bridge stairs.

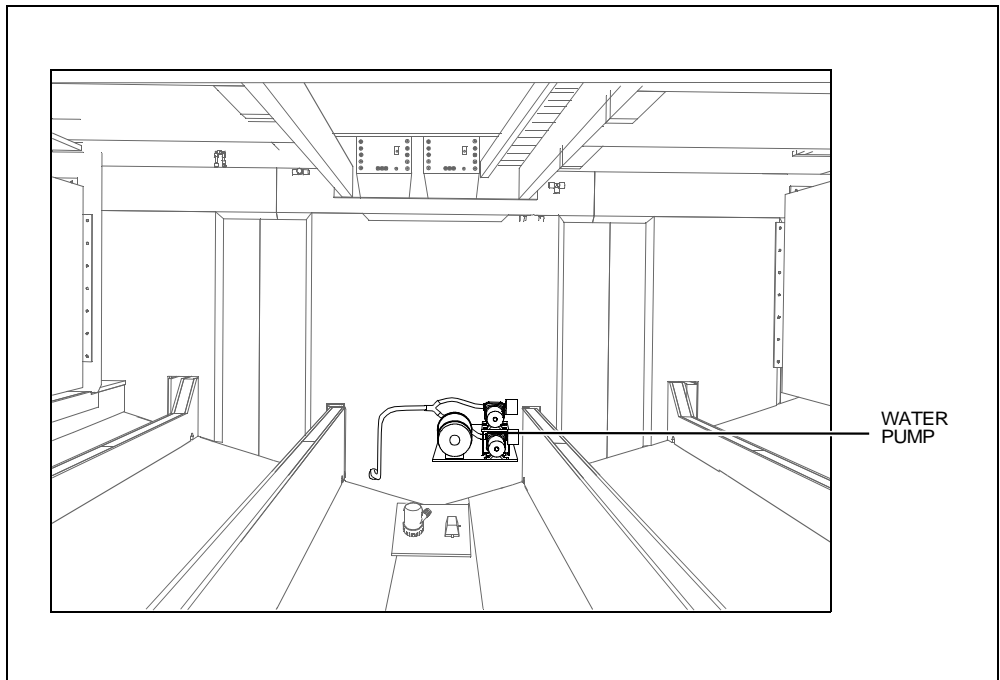

Water Pump Switch:

- Located inside the cabinet on the port side wall of the pilothouse staircase.

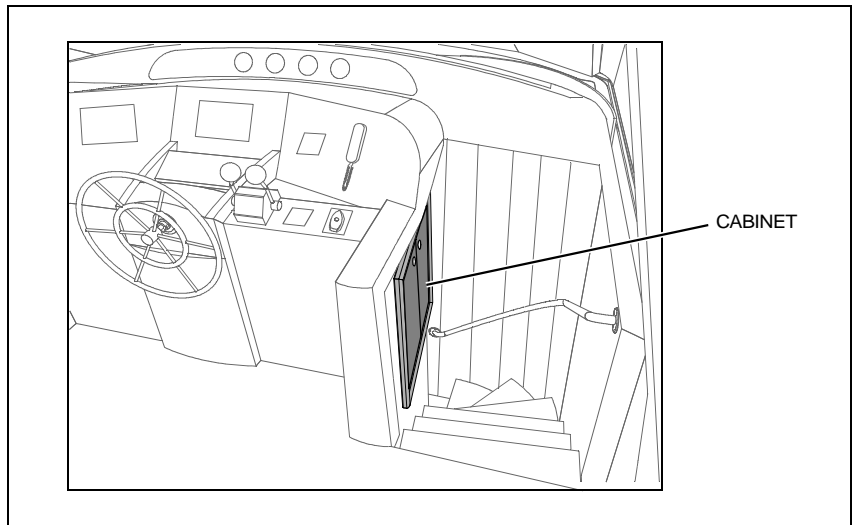

Chapter 3: Propulsion & Related Systems

Engines

Read and understand the engine operation and maintenance manuals *before* using or working on the engines.

Engine Cooling System

! **CAUTION!**

SYSTEM DAMAGE HAZARD!

The engine cooling system's seacocks *must* be *Opened before* engines are started and during engine operation.

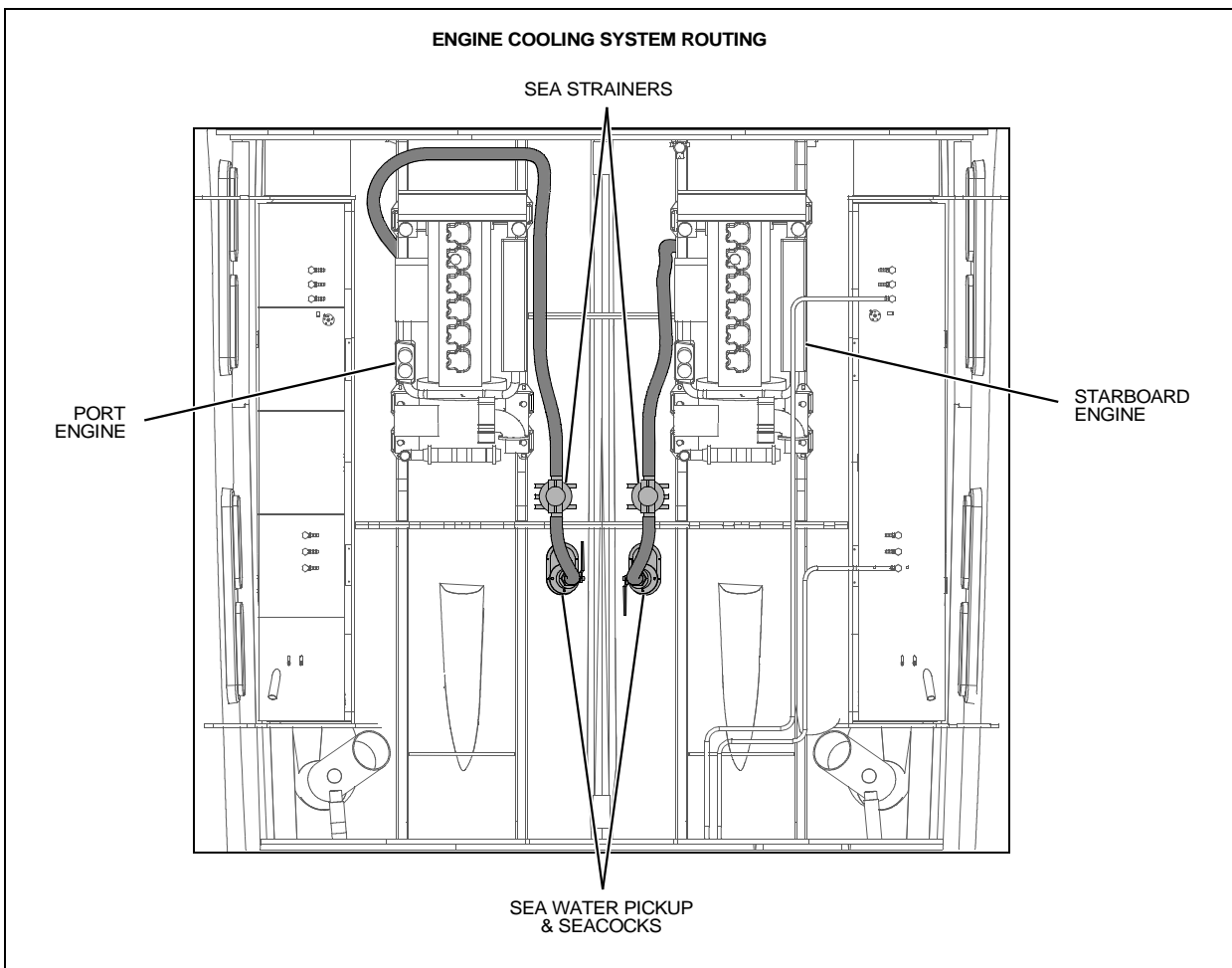

The engine cooling system circulates raw water around components and also uses a freshwater heat exchanger on the engine to reduce engine temperature.

- Make sure both engine seawater intake valves (seacocks) are *Open before* starting the engines and keep the seacocks *Open* while the engines are running.
- The cooling system's seawater strainers should be checked for leaks and debris every time you use your yacht. For instructions on how to clean the seawater strainers, see the *Seawater Systems* section of this manual.

Exhaust System

⚠ **DANGER!**

CARBON MONOXIDE POISONING HAZARD!



Leaking engine and/or generator exhaust is a source of dangerous carbon monoxide gas (CO). Check *all* exhaust systems *before* each trip.

- Look for leaks in the exhaust systems of the propulsion engines and the generator.
- Look for discoloration, water leaks, carbon or stains around *all* joints.
- Make sure *all* of the exhaust clamps are in place and secured.
- Make sure the ventilation systems work and are *not* obstructed or restricted.
- To reduce the chance of CO entering the living spaces, fill any gaps around engine room plumbing, cableways, exhaust systems, doors, hatches, and access panels.

- The exhaust system is designed to keep seawater out of the engines in most sea conditions.
- However, *do not* anchor the stern to sea or shut the engines *Off* if high seas might flood the exhaust system.
- *Always* consider the sea conditions *before* anchoring or shutting *Off* the engines.

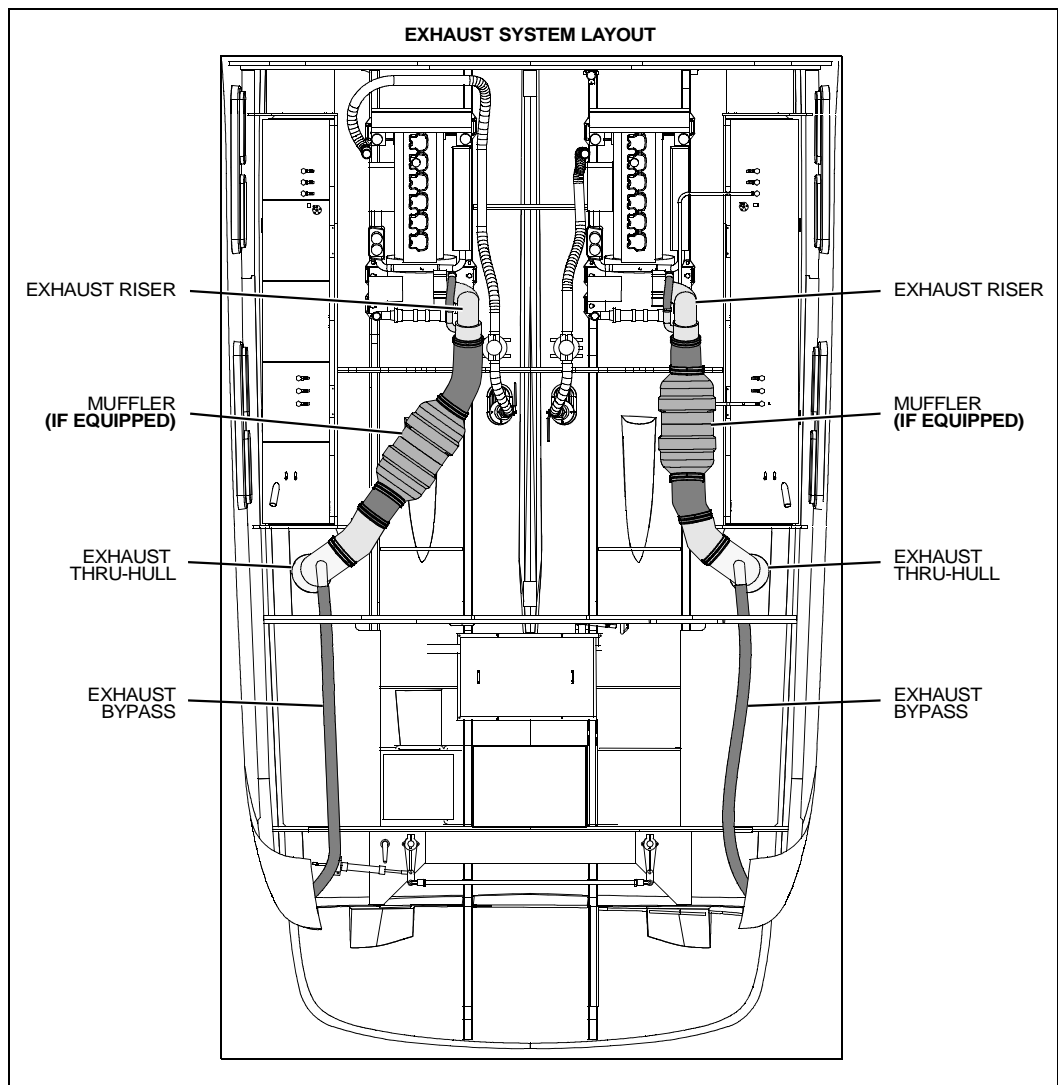

Engine Room Ventilation System

⚠ WARNING!

☞ ⚠ 🔥 **FIRE/EXPLOSION HAZARD**

- Use of the blower system is **NOT A GUARANTEE** that explosive fumes have been removed.
- If you smell fuel, **DO NOT** start the engines or generator and **DO NOT** turn **On** any electrical devices.
- If you smell fuel and the engines and/or generator are already running, shut **Off** the engines and/or generator and turn **Off all** electrical devices. Investigate **immediately**.
- **DO NOT** obstruct or modify the ventilation system.

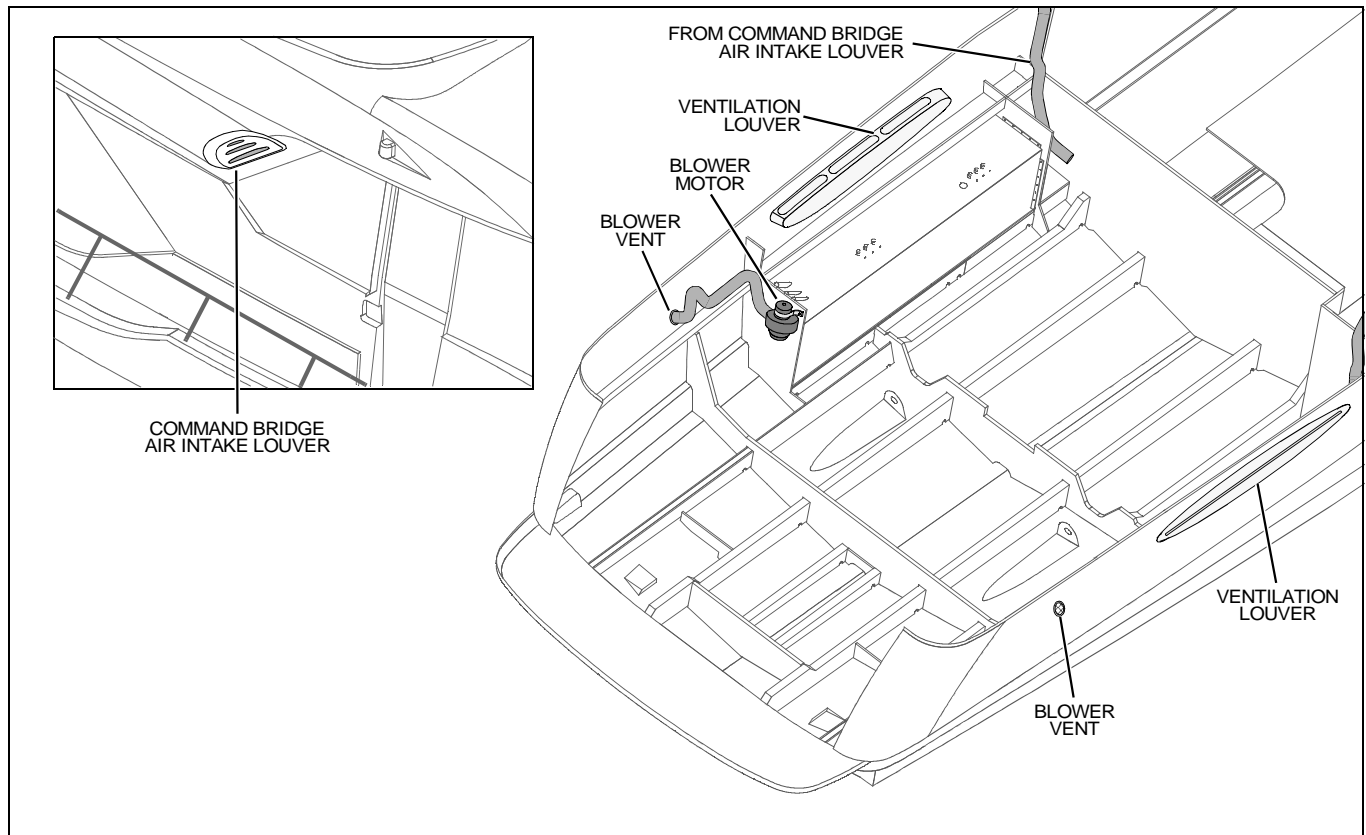

- The bilge blowers remove explosive fumes from the engine room.
- Fresh air is drawn into the engine room through the deck vents.
- The bilge blower switch is located on the switch panel at the helm.

To make sure the engine room is properly ventilated:

- **Always** run the bilge blowers for at least four minutes **before** starting the engines or the generator (if equipped).
- Continue to run the blowers until your yacht has reached cruising speed.
- **Always** run the blowers when operating the yacht below cruising speed.

Fuel System

! WARNING!



FIRE, EXPLOSION AND OPEN FLAME HAZARD!

- It is very important that the fuel system be inspected thoroughly the first time it is filled and at each subsequent filling.
- The fueling instructions in the *Owner's Manual* and the fuel recommendations in the engine operation manual *must* be followed.

! CAUTION!

- Air in the diesel supply system can stop an engine or severely restrict performance. If you suspect air in the fuel lines, refer to your engine operation manual for detailed instructions on how to *bleed* the system.

! CAUTION

Avoid the storage or handling of gear near the fuel lines, fittings and tank.

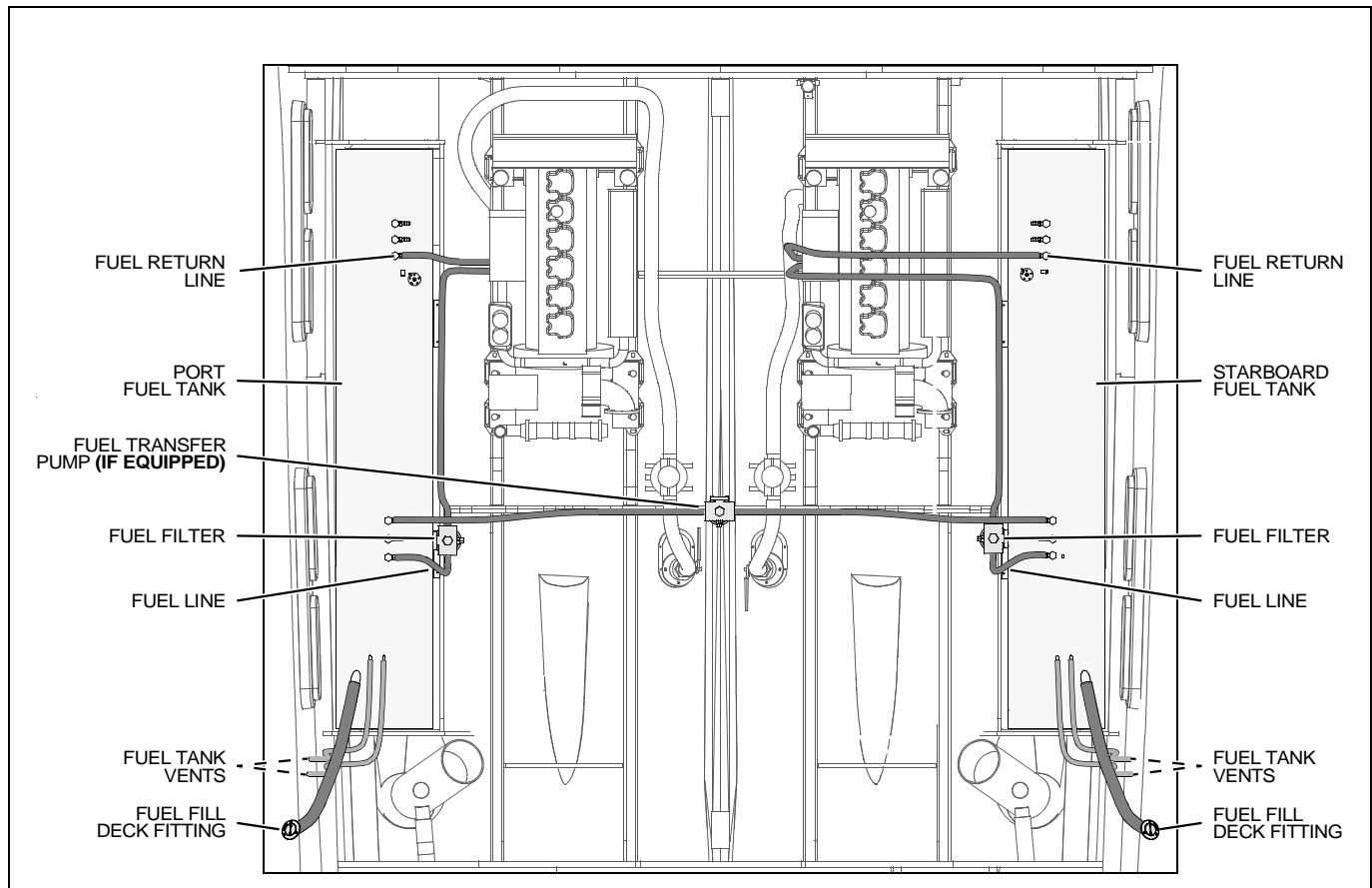

- Carefully read the fuel section of both the *Owner's Manual* and the engine operation manual, paying special attention to the subject of *fuel recommendations*.

Fuel Fills & Vents

- The fuel fill fittings are marked “Diesel”.
- If you experience difficulty filling the fuel tank, check to see if the fuel fill hose is kinked or collapsed. If there are no visible signs of a problem, contact your local dealer.

Fuel Transfer Pump (If Equipped)

 CAUTION!
<i>ENVIRONMENTAL HAZARD!</i>
<i>NEVER transfer fuel into a full (or nearly full) fuel tank. Fuel transferred into a full tank may spill overboard through the tank venting system.</i>

Your yacht may feature a fuel transfer pump which pumps fuel from one tank to another. The fuel transfer pump switch is located at the upper helm station.

Fuel Filters

- The fuel pickup tube (located inside the fuel tank) is equipped with a fine mesh screen filter.
- In addition, when supplied by the engine manufacturer, a fuel filter is installed on the engine.
- Periodically replace the fuel filters to make sure they remain clean and free of debris.
- Consult with your selling dealer or local marina concerning fuel additives that help to prevent fungus or other buildup in your fuel tank.

Oil Change System (If Equipped)

- Your yacht may feature an oil change pump to simplify draining and filling engine and generator oil.
- See the oil change system instructions for information on the use of this system.

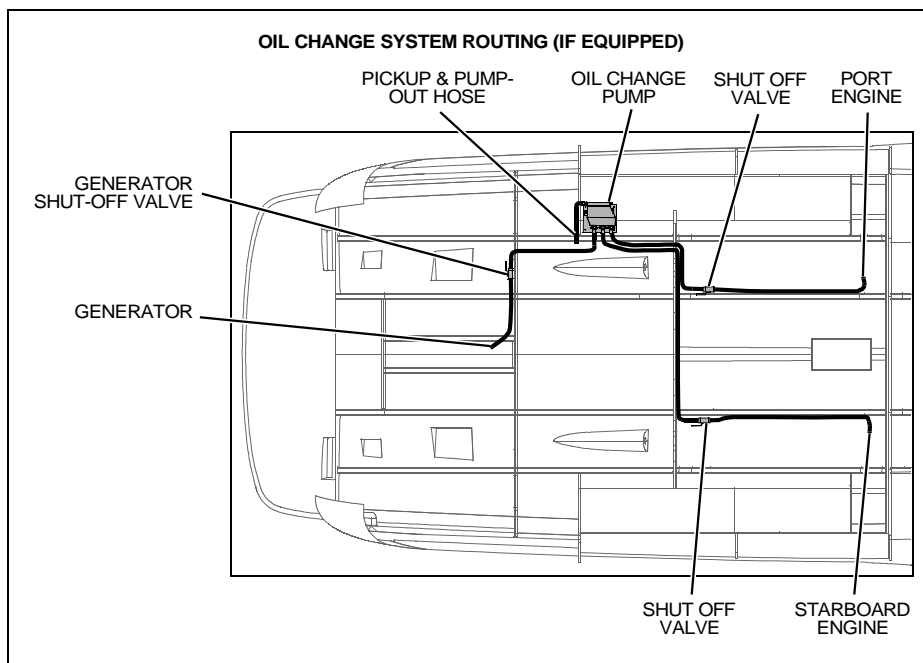

Fire Suppression System (If Equipped)

Before using your boat for the first time, read and understand the fire suppression system's instruction and maintenance manual and follow **all** warnings.

Observe the following:

- The system **will** go off automatically whenever direct heat from a fire is detected in the engine compartment.
- The system can be set off manually by pulling the T-handle (labeled "FIRE") at the helm.
- The system can **only** be set off **once**. After the system is discharged it **must** be refilled and refurbished **before** it can be used again.

Shaft-Transmission Alignment



CAUTION!

SYSTEM DAMAGE HAZARD!

- If you suspect a shaft-transmission misalignment, have a qualified mechanic perform an alignment inspection as soon as possible.
- Continued use may lead to premature engine, transmission, shaft, shaft seal and/or hull damage!

Alignment between the engine transmission output shaft and the propeller is very critical. The alignment has been performed at the factory and was rechecked by the dealer after the yacht had been in the water for 48 hours.

- An alignment inspection should be performed by a marine mechanic as part of the routine maintenance program after the initial 30 hours of operation, then every 60 hours and whenever unusual noise or vibration is noticed.
- Shaft-transmission alignment should be performed by a marine mechanic since it requires moving the engine and prop shaft.
- To insure proper alignment after a haul out or dry storage, wait 48 hours after launching before final alignment adjustments by a marine mechanic are made.

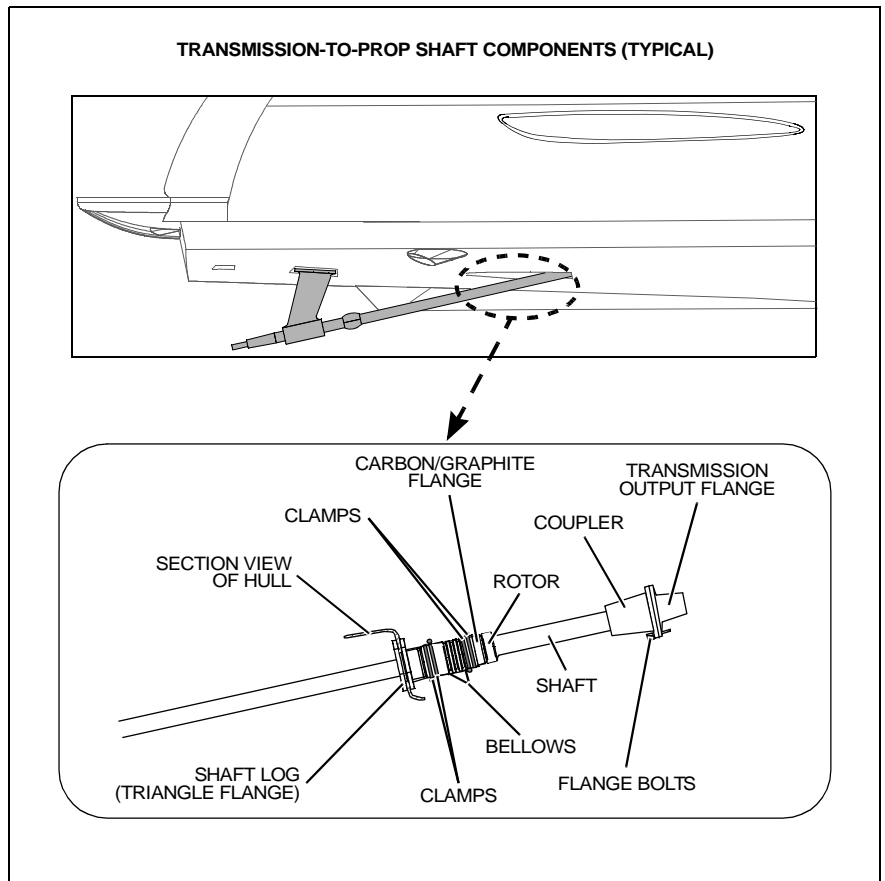

Shaft Log Packless Sealing System

The shaft log packless sealing system's shaft seal is a maintenance-free, watertight seal that does *not* require packing or adjustments.

Chapter 4: Controls & Gauges

Steering

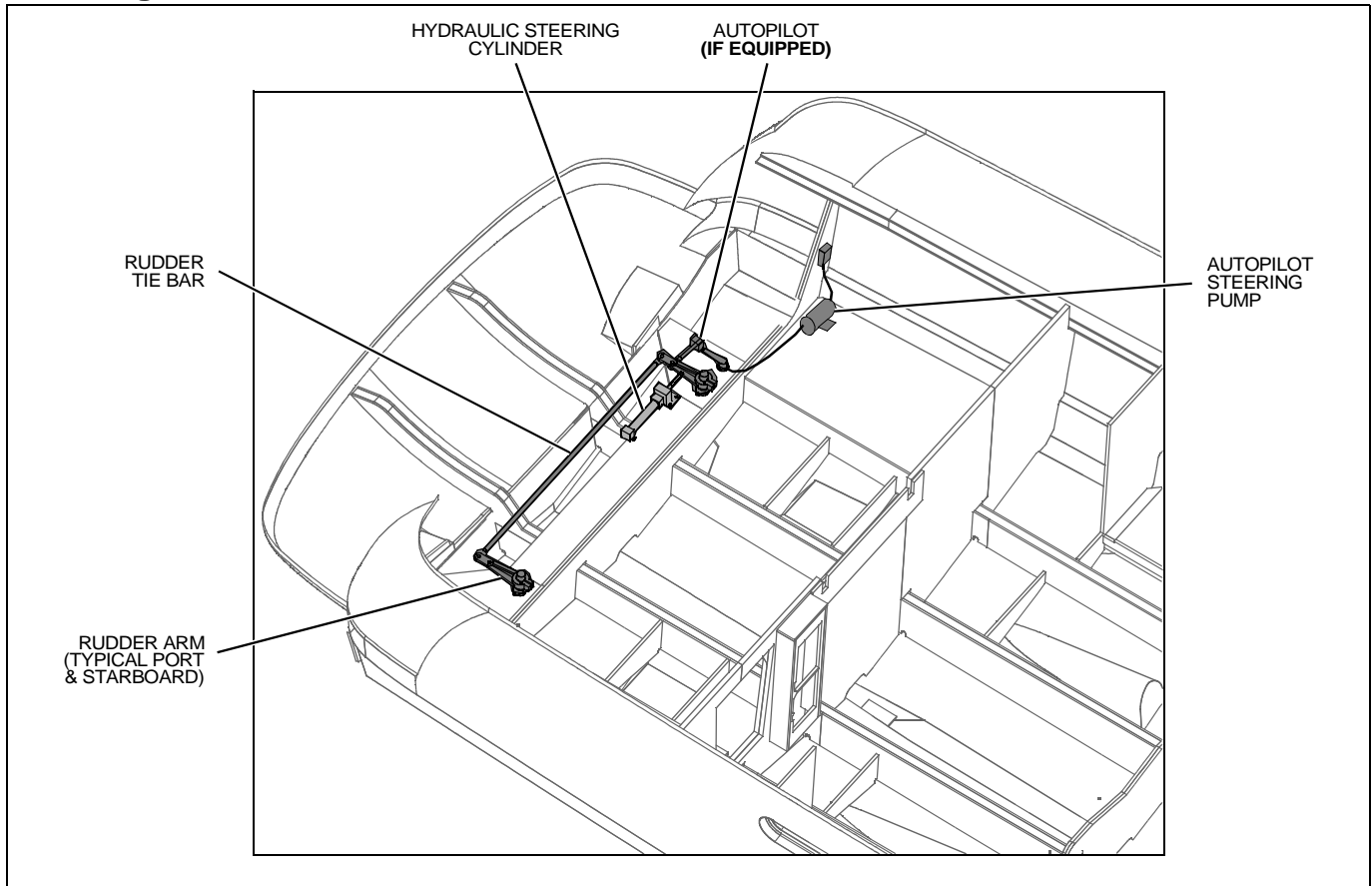

- This yacht features a hydraulic steering system.
- Check the fluid level in the hydraulic steering reservoir every time you use your yacht.
- Yacht steering is *not* self-centering.

Rudder Stuffing Gland

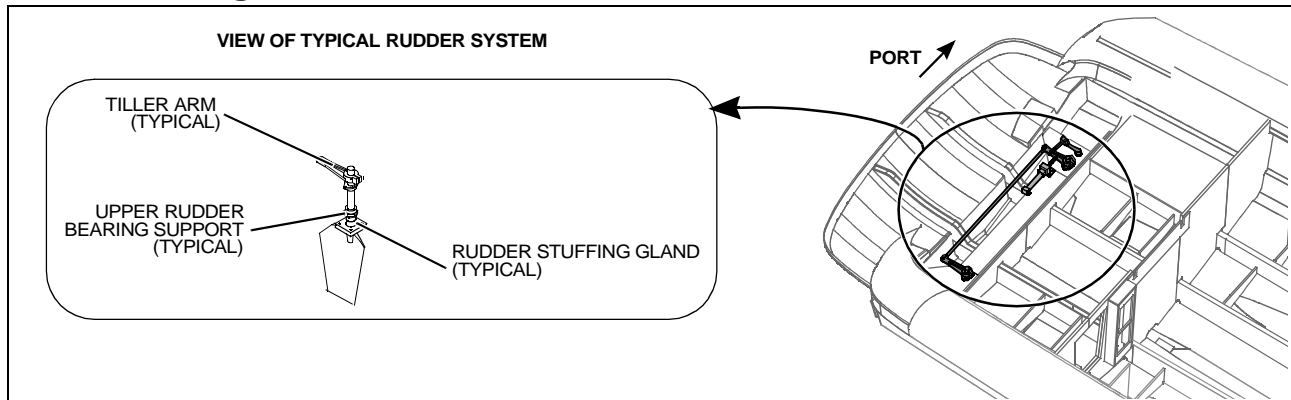

- The rudder stuffing gland is part of the assembly where the rudders emerge from the bottom of the yacht.
- The shaft stuffing gland should **not** leak any water.
- If a leak develops, it can usually be stopped by tightening the packing gland nuts slightly.
- **Do not** over tighten the packing gland nuts.
- If stuffing gland leakage becomes excessive, packing replacement can be performed as follows:
 1. Remove the yacht from the water.
 2. Loosen the packing gland nuts and back the packing gland from the sleeve.
 3. Remove the old packing.
 4. Wrap new packing around the shaft.
 5. Cut the rings with a razor blade at an angle approximately 30 degrees to the long axis of the shaft.
 6. Stagger the ends of each ring around the shaft and insure that the rings are at the bottom in the sleeve.
 7. Tighten the packing gland nuts until resistance is felt.

Autopilot (If Equipped)



WARNING!

- **Never** leave the helm while the autopilot system is *On*!
- A qualified operator **must** monitor the autopilot system at *all* times and keep lookout for other marine traffic and other hazards.

NOTICE

- The autopilot system is *only* an aid to navigation.
- Its accuracy can be affected by many factors, including equipment failure or defects, environmental conditions & improper handling or use.

- **Before** using the autopilot system, read the autopilot instruction manual(s).
- The autopilot **will** aid you in maintaining the chosen course of your yacht.

Shift/Throttle Controls

! **WARNING!**

LOSS OF CONTROL HAZARD!

Improper maintenance of shift/throttle hardware may cause a sudden loss of control!

Read *all* of the information about the shift/throttle controls in the shift/throttle controls' manual, the engine operation manual, and the *Cruiser & Yacht Owner's Manual Supplement*.

Engine Synchronization (If Equipped)

Follow the instructions in the synchronization section of the shift/throttle controls' manual.

Trim Tabs

! **WARNING!**

LOSS OF CONTROL HAZARD!

Improper use of trim tabs will cause loss of control!

- **Do not allow anyone unfamiliar with trim tabs to use them.**
- **Do not use trim tabs in a following sea as they will cause broaching or other unsafe handling characteristics.**
- **Do not use trim tabs to compensate for excessive unequal weight distribution.**

- The trim tabs may be used to help keep your yacht level at cruising speeds.
- The trim tabs are controlled by two rocker switches at the helm.
- **Before** using the trim tabs read and understand the trim tab operation manual.

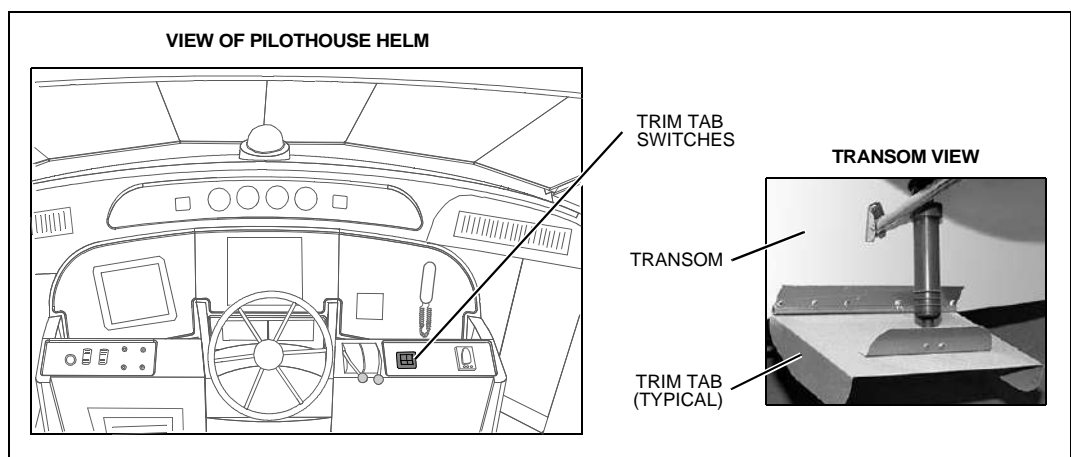

Observe the following:

- Once cruising speed is reached, the port or starboard trim switch may be used (one at a time) to level the yacht.
- Perform trim tab adjustment with several short touches to the switch rather than one long one.
- After each short touch allow several seconds for the hull to react.
- The trim tab hydraulic fluid reservoir is located in the engine compartment. The fluid level *must* be checked periodically (at least once a year) and refilled as necessary.

Docking On Command (D.O.C.) System (If Equipped)

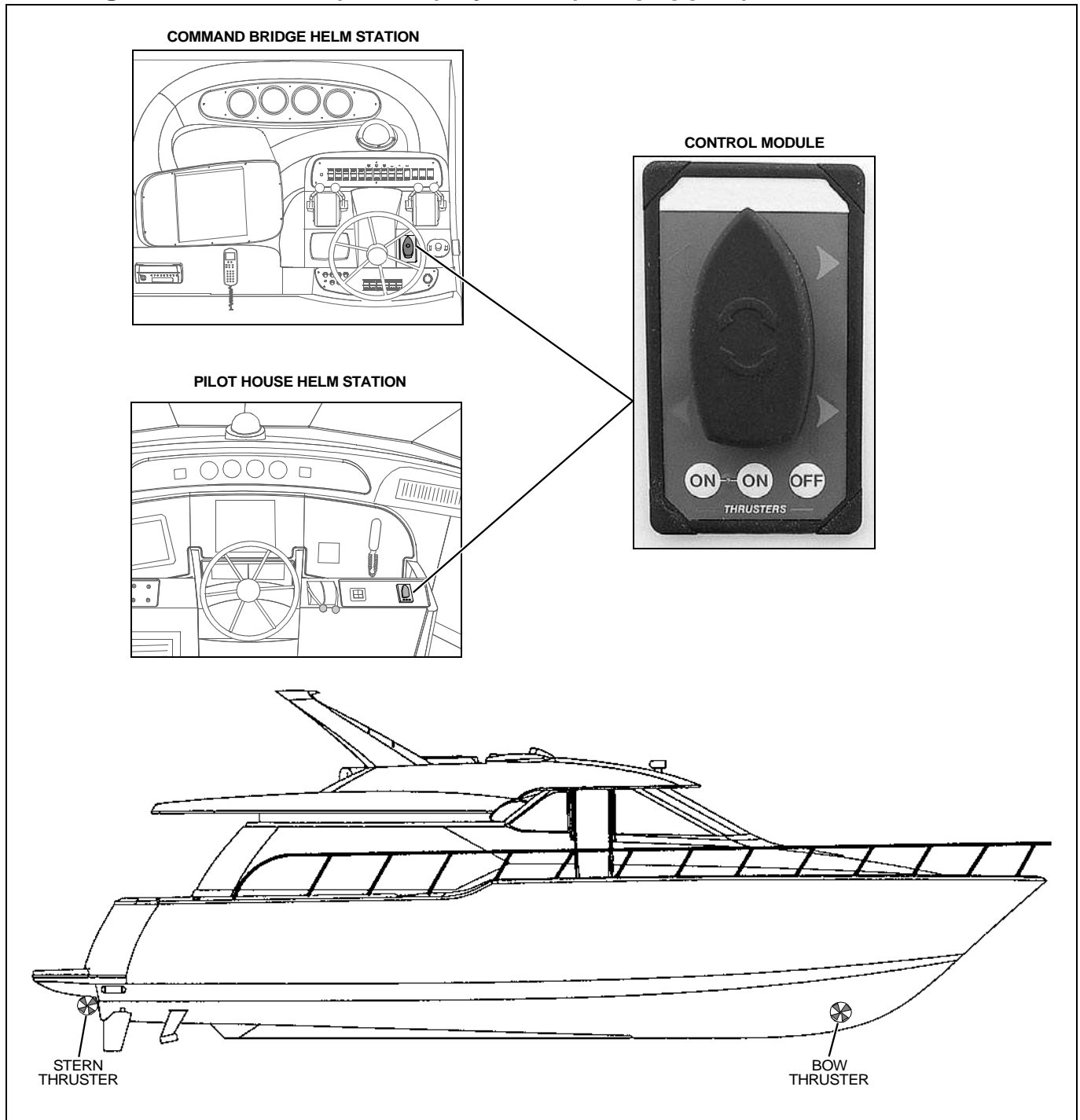

- The D.O.C. system features bow and stern thrusters.
- The thrusters can be controlled from either helm.
- During docking, the thrusters can assist you in maneuvering your yacht in close quarters.
- Read the D.O.C. system's user manual *before* using the D.O.C. system for the first time. Follow *all* user precautions carefully.

Gauges

Cleaning Gauges

 CAUTION!
<i>PRODUCT or PROPERTY DAMAGE HAZARD!</i>
<ul style="list-style-type: none">• Use only mild soap and water to clean the gauge lenses and bezels.• Use of other cleaners, including common window cleaning solutions, may cause the lenses to crack.• Lenses cracked in this manner <i>will not</i> be covered by our warranty.

Gauge Fogging

- Moisture may occasionally find its way into the gauges causing lens fogging.
- Turning ***On*** the gauge lights will help dry the lenses.
- Fogging ***will not*** harm the gauges.

Radio Transmission Interference

VHF or other radio transmissions may cause brief erratic readings on tachometers and/or synchronizers. This ***will not*** damage these gauges or affect their accuracy when ***not*** transmitting.

Twin Engine Readings

It is normal for tachometers and other gauges to have slightly different readings between engines.

Fuel Gauge

It is normal for the pointers on your fuel gauges to bounce as fuel sloshes back and forth in the fuel tanks.

Chapter 5: Navigation & Communication Equipment

Before using these systems for the first time, read and understand the instruction manuals and observe the following:

Compass

NOTICE

- **Compass accuracy can be affected by many factors.**
- **Have a qualified technician calibrate your compass. Make sure the technician gives you a deviation card which shows the corrections to apply in navigational calculations.**
- **Keep a copy of the deviation card at each helm.**

Depth Finder



WARNING!

- ***DO NOT* use the depth finder as a navigational aid to prevent collision, grounding, yacht damage or personal injury.**
- **When the yacht is moving, submerged objects *will not* be seen until they are already under the yacht.**
- **Bottom depths may change too quickly to allow time for the yacht to react.**
- **If you suspect shallow water or submerged objects, run the yacht at very slow speeds.**

VHF Radio (If Equipped)

- The VHF (Very High Frequency) radio can be used to access weather reports, summon assistance or contact other vessels as permitted by the FCC (Federal Communications Commission).
- Contact the FCC for licensing, rules and regulations concerning VHF radio usage.

Radar (If Equipped)

 **WARNING!**

Radar is meant to help the navigator, *not* replace him/her. The operator is responsible for keeping a visual look-out for possible collision situations. No single navigation aid (including this radar) should be relied upon as the only method for navigating your yacht.

NOTICE

The radar system is *only* an aid to navigation. It's accuracy can be affected by many factors, including equipment failure or defects, environmental conditions & improper handling or use.

- The marine radar system gives you a complete and accurate 360° radar view of other vessels, buoys, and landfall surrounding your vessel.
- To turn this system *On*, the RADAR switch on the DC breaker panel must be switched *On*.

Global Positioning System (GPS) (If Equipped)

 **WARNING!**

The *GPS* system should *not* be relied upon as the only aid to navigation. A qualified operator *must* monitor the *GPS* system at *all* times and keep look-out for other marine traffic and possible collision situations.

NOTICE

The *GPS* system is *only* an aid to navigation. It's accuracy can be affected by many factors, including equipment failure or defects, environmental conditions & improper handling or use.

GPS receivers provide reliable and accurate position data, anywhere in the world.

Chapter 6: Plumbing

Bilge Pumps

NOTICE

Discharge of oil, oil waste or fuel into navigable waters is prohibited by law. Violators are subject to legal action by the local authorities.

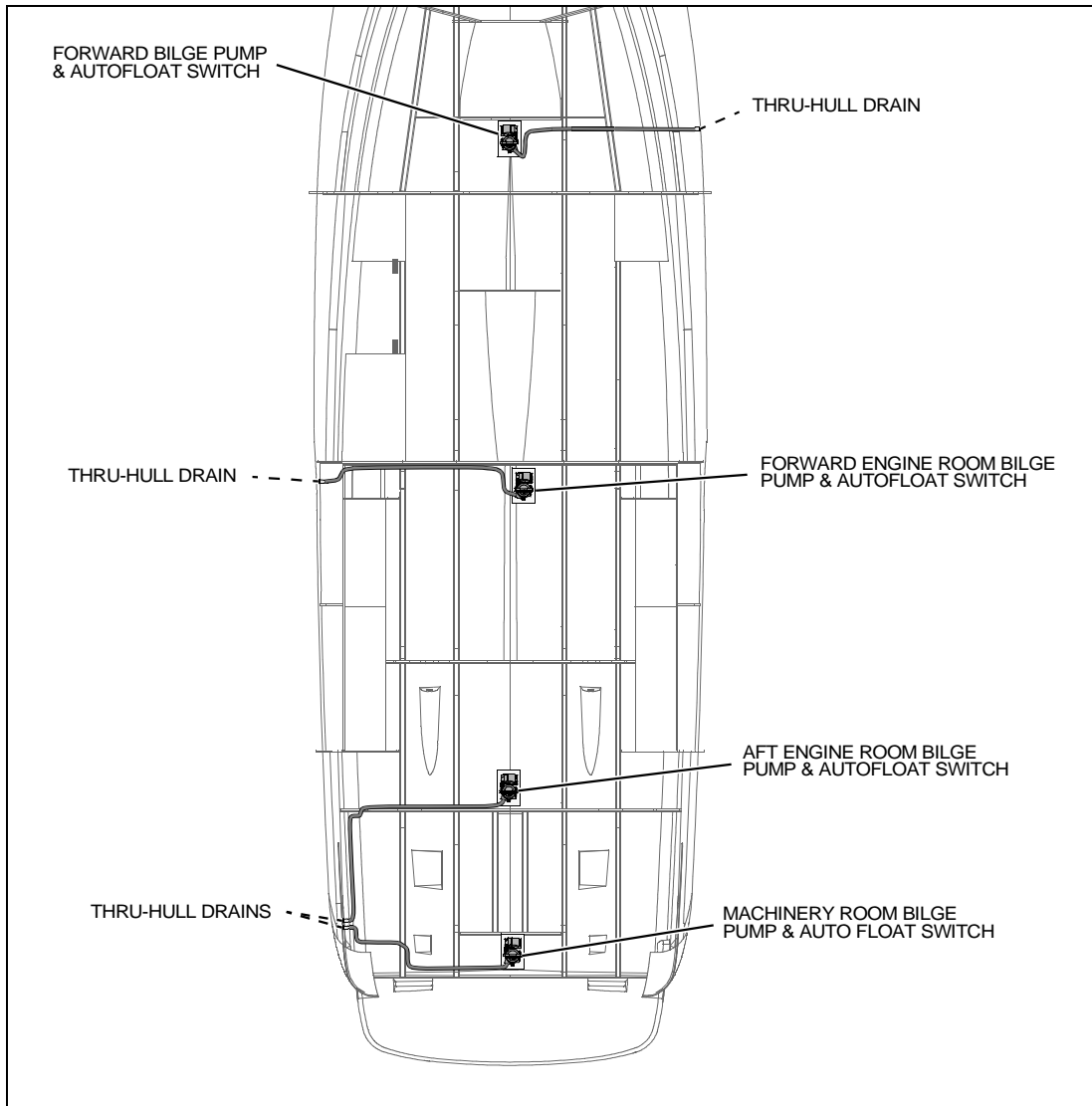

- Your yacht is equipped with four bilge pumps which are used to pump water out of the bilge.
- The bilge pumps are controlled by automatic float switches (autofloat switches) and/or switches at the helm.
- The bilge pumps are wired directly to the battery. They will normally function even when the yacht is completely shut down and left unattended.

Bilge Pump Testing

Bilge pumps are critical to the safety of your yacht. Check the bilge pumps often to make sure that they are working properly. Test each pump individually.

To test each bilge pump:

1. Turn **On** the manual switches at the helm.
2. Make sure that water in the bilge is pumped overboard.

If there is water in the bilge and the pump motor is running but **not** pumping:

1. Inspect the discharge hose for a kink or collapsed area.
2. Check the bilge pump housing for clogging debris as follows:

To check for clogging debris in pumps:

1. With your thumb and forefinger squeeze the holding tabs on each side of the power cartridge.
2. Lift out the power cartridge.
3. Check the pump and the housing and clear any debris.

Reinstall the power cartridge:

1. Align the tabs and slots and press firmly until the tabs click into place.
2. Make sure that the power cartridge is locked into place.

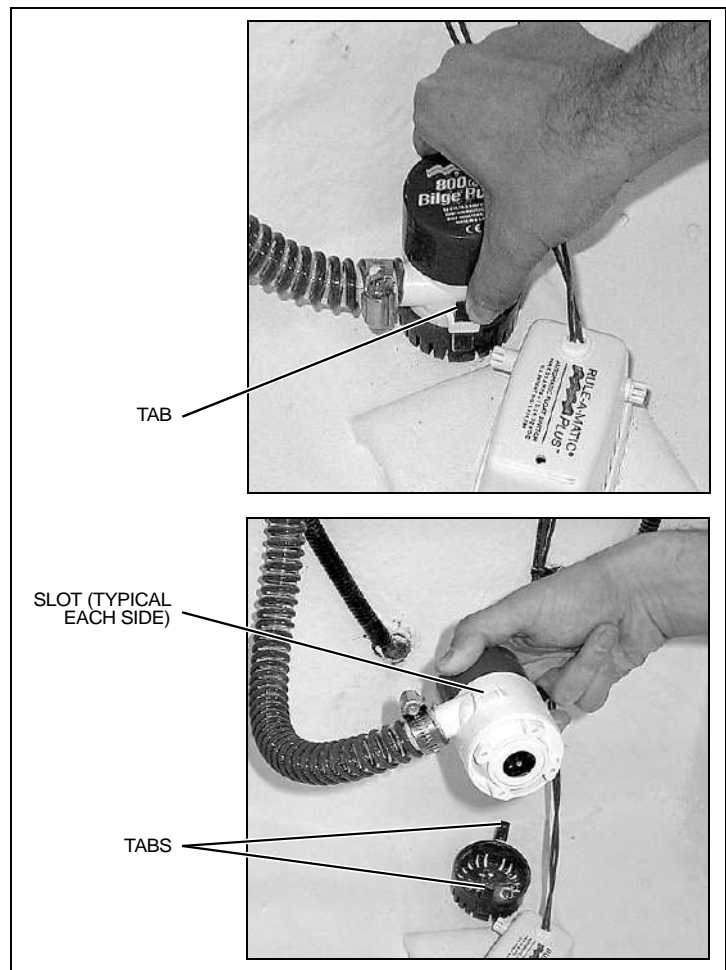

Autofloat Switches

- The automatic bilge pumps use float (autofloat) switches to automatically turn **On** the pumps whenever water rises to a preset level in the bilge.
- The autofloat switches are normally mounted next to the bilge pumps they control.
- The autofloat switches should be tested often for proper operation as follows.

To test a float switch:

1. Turn **On** the float switch by twisting the white plastic knob 1/4 turn.
2. The bilge pump should turn **On**.
3. If twisting the knob does **not** turn the pump **On**, check the circuit breaker on the battery management panel.
4. If the circuit breaker is **On**, but the pump still does **not** work, it may indicate a bad switch or possibly a low battery.
5. Release the knob to lower the float and return the float switch to auto mode.

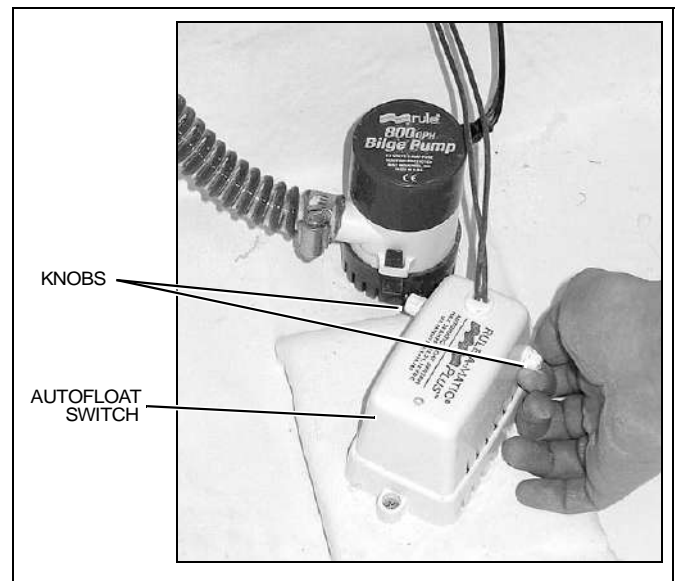

CAUTION!

When the test is completed on each float switch, you **MUST** push the test button *all the way down* to the auto position to return the switch to auto mode!

Seawater Systems

Seacocks



CAUTION!

SYSTEM DAMAGE HAZARD!

- **Before using a seawater intake system, make sure that the system's seacock is in the *Open* position before the system is started and keep the seacock *Open* until the system is shut *Off*.**
- **Close the seacocks whenever the systems will not be used for long periods of time.**

A seacock is a valve, controlled by a 90° lever, used to manage the intake of seawater through the hull and below the water line. Seacocks are typically used on your yacht in the following seawater intake systems:

- Engines
- Generator (if equipped)
- Air conditioning system (if equipped)

Before using any of these systems, make sure that the system's seacock is **Open** and remains **Open** until the system is shut **Off**.

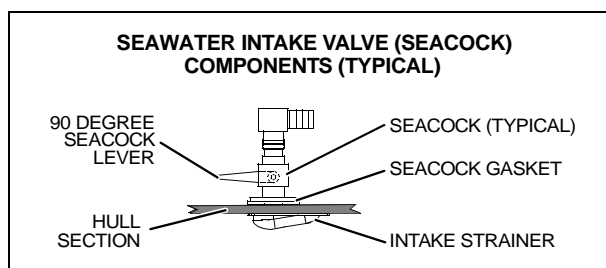

Seawater Strainers

- Seawater strainers are used in water pickup systems to filter incoming seawater.
- A seawater strainer is located near each system's seacock.
- Check the strainers for leaks and/or debris every time you use your yacht.
- If debris is found, clean the seawater strainer as follows:



CAUTION!

FLOODING HAZARD!

- **The seacock that sends seawater to the strainer must be *Closed* before disassembling the seawater strainer to prevent the yacht from taking on water through the seawater strainer assembly.**
- **Keep the seacock *Closed* until the seawater strainer is completely reassembled.**

SYSTEM DAMAGE HAZARD!

- **After reassembling the seawater strainer, make sure that the seacock valve is *Open* before using the component/system.**

1. Make sure the component/system (generator, air conditioning system, etc.) that the strainer is connected to is turned **Off**.
2. **Close** the seacock that sends seawater to the strainer you are about to clean. The seacock **must** remain **Closed** until the strainer is completely reassembled.
3. Take apart the seawater strainer.
4. Remove the debris.
5. Flush the strainer with water.
6. Reassemble the seawater strainer.
7. **Open** the seacock and check for leaks around the strainer. If **no** leaks are found, you may use the component or system.

Raw Water Washdown (If Equipped)**CAUTION!****FLOODING & SWAMPING HAZARD!**

NEVER leave the boat unattended while using the "raw water" feature. Any leak or break in the system may allow large amounts of water to accumulate in the bilge that could cause swamping of the batteries and engines or sinking of the boat.

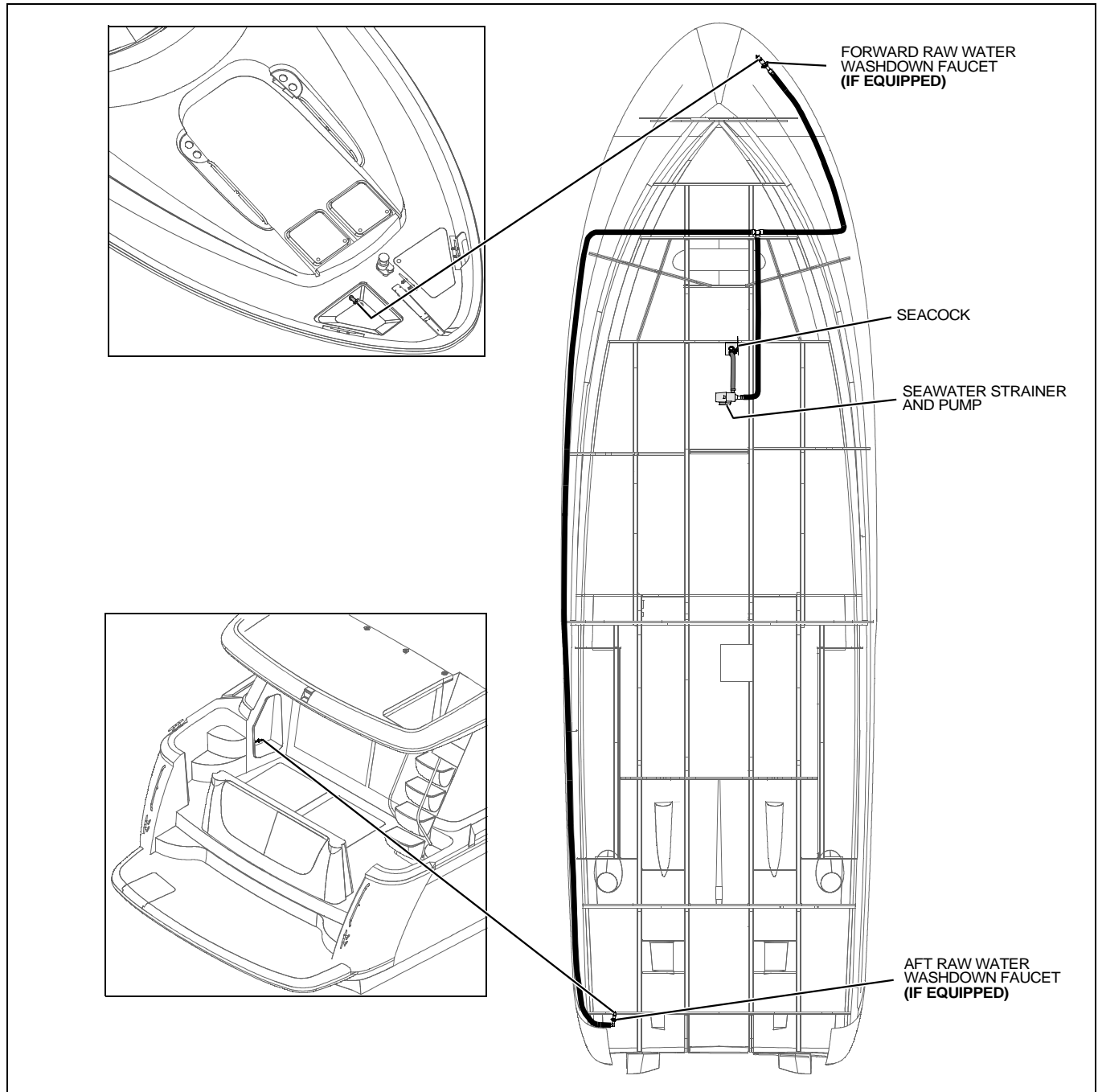

- **Always** make sure the seacock is **Open before** turning the raw water washdown system **On**.
- The seacock is accessed through the V-berth floor cutouts.

Freshwater System

⚠ WARNING!

- **Only use safe drinking (potable) water in your yacht's freshwater system.**
- **Only use a sanitary drinking water hose to fill the water tank or connect to city water.**
- **Never use a common garden hose for drinking water.**

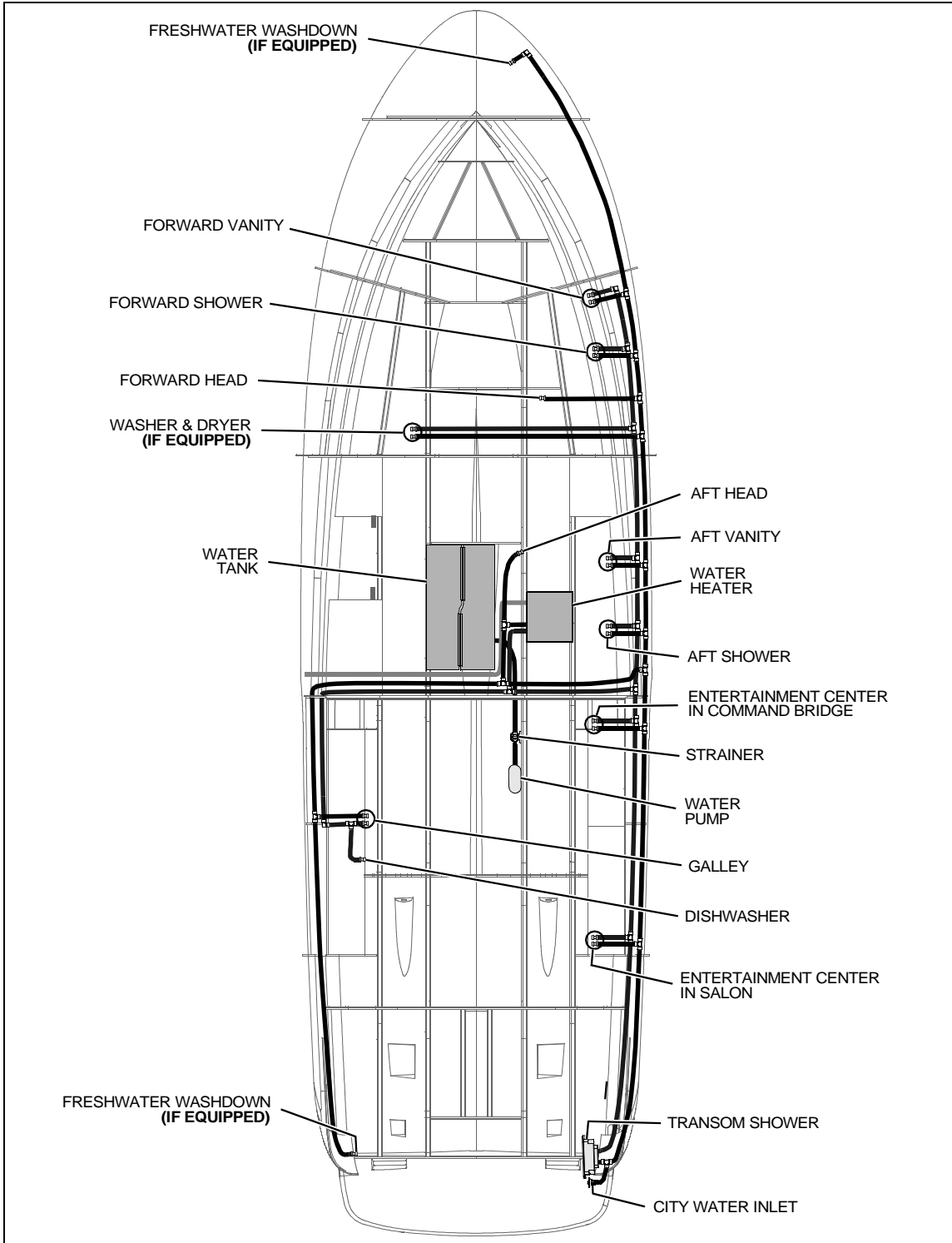

- Read the *Freshwater system* section in the *Cruiser & Yacht Owner's Manual Supplement*.
- Your yacht is equipped with a pressure type (demand) freshwater (potable) system.
- This system can be pressurized by turning **On** the water pump.
- See the *Component Location* section of this *Supplement* for the location of the water pump switch.
- Since the water pump requires DC power, the battery switch must be in the **On** position for the pump to work.

Observe the following about the freshwater system:

- Turn **Off** the water pump when the yacht is **not** in use or the water tank is empty.
- Inspect and clean the water filter often (located on the water pump).
- When your yacht is to be left unattended for long periods of time, pump the water tank dry to prevent stored water from becoming stagnant and distasteful.
- If the freshwater system needs to be disinfected, ask your dealer about treatments available for your yacht's system.

Freshwater System Winterization

 **CAUTION!**

WATER SYSTEM DAMAGE HAZARD!

Never blow compressed air through the water system when *all* of the faucets are Closed.

1. Turn **On** the water system switch.
2. **Open all** of the faucets and showers and let the water system drain completely.
3. Turn **Off** the water system switch.

Any remaining water **must** be removed from the water lines. There are two ways to remove the remaining water from the lines:

- Compressed Air
- Gravity Draining

Compressed Air

You **must** have an air compressor with an air hose and an air nozzle.

1. Remove the water line from the outlet side of the water pump (opposite side from filter).
2. **Open** the faucet that is furthest away from the water pump.
3. Place the air nozzle against the end of the just removed water line and blow air through the system.
4. When water stops coming out of the **Open** faucet, stop the air and **Close** the faucet.
5. One at a time, repeat this process on **all** faucets and showers.

Gravity Draining

1. **Open all** faucets and showers.
2. Remove the drain plug from the tee fitting on the freshwater tank.
3. When the water has stopped draining from the freshwater tank, replace the drain plug.

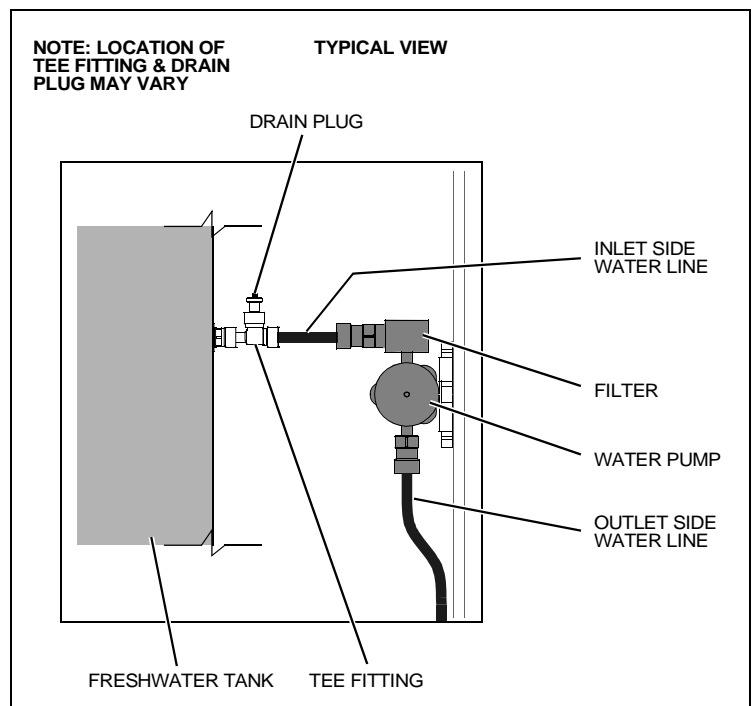

Water Heater

! WARNING!

! HOT HAZARD!
Water heated by the water heater can reach temperatures hot enough to scald the skin.

! CAUTION!

WATER HEATER DAMAGE HAZARD!

- **DO NOT** turn *On* the water heater electrical circuit on the AC panel until the water heater tank is **COMPLETELY** filled with water.
- Even momentary operation in a dry tank will damage the heating elements.
- Warranty replacements **WILL NOT** be made on elements damaged in this manner.
- The tank is full if water flows from the tap when the hot water is turned *On* in the galley.
- The water heater should be drained and the power turned *Off* when the possibility of freezing exists.

NOTICE

If your yacht is connected to shore power or generator power, but the water heater is *not* working:

- Make sure the water heater circuit breaker on the AC panel is switched *On*.

If the circuit breaker on the AC panel is *On*, but the water heater is still *not* working:

- Consult with your dealer about checking the "push to reset" circuit breaker located on the water heater.

- Read the water heater instruction manual and heed the warnings above.
- The water heater is connected to the 120-volt, AC power system.
- Turn *On* the water heater breaker on the AC panel to heat the water.

Winterizing the Water Heater

1. Turn *Off* the water heater breaker.
 2. Disconnect the hose (A) attached to the pressure relief valve (B).
 3. If there is any water in this hose, drain it into the bilge or into a bucket.
 4. **Open** the pressure relief valve (B).
 5. **Open** the drain valve (C).
- Leave the pressure relief and drain valves **Open** until you fit out the boat after storage.

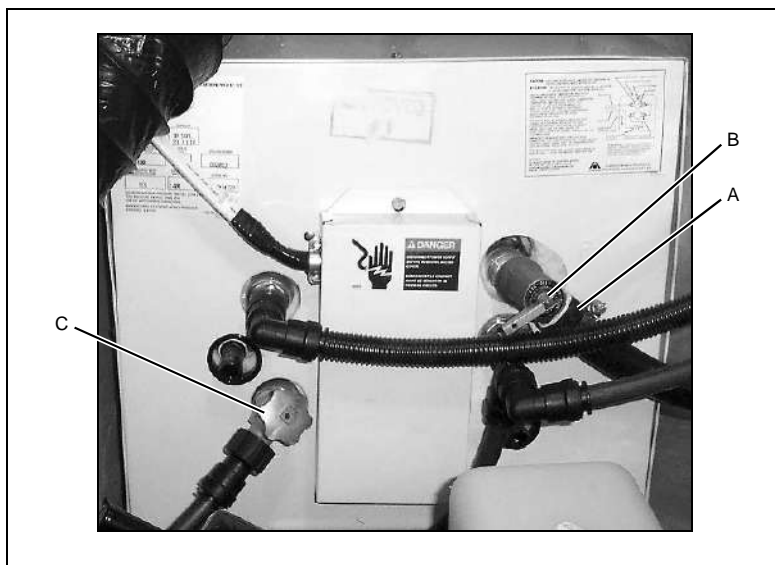

City Water Inlet



CAUTION!

FLOODING & SWAMPING HAZARD!

NEVER leave the yacht unattended while using the "city water" feature. Any leak or break in the system may allow large amounts of water to accumulate in the bilge that could cause swamping of the batteries and engines or sinking of the yacht.

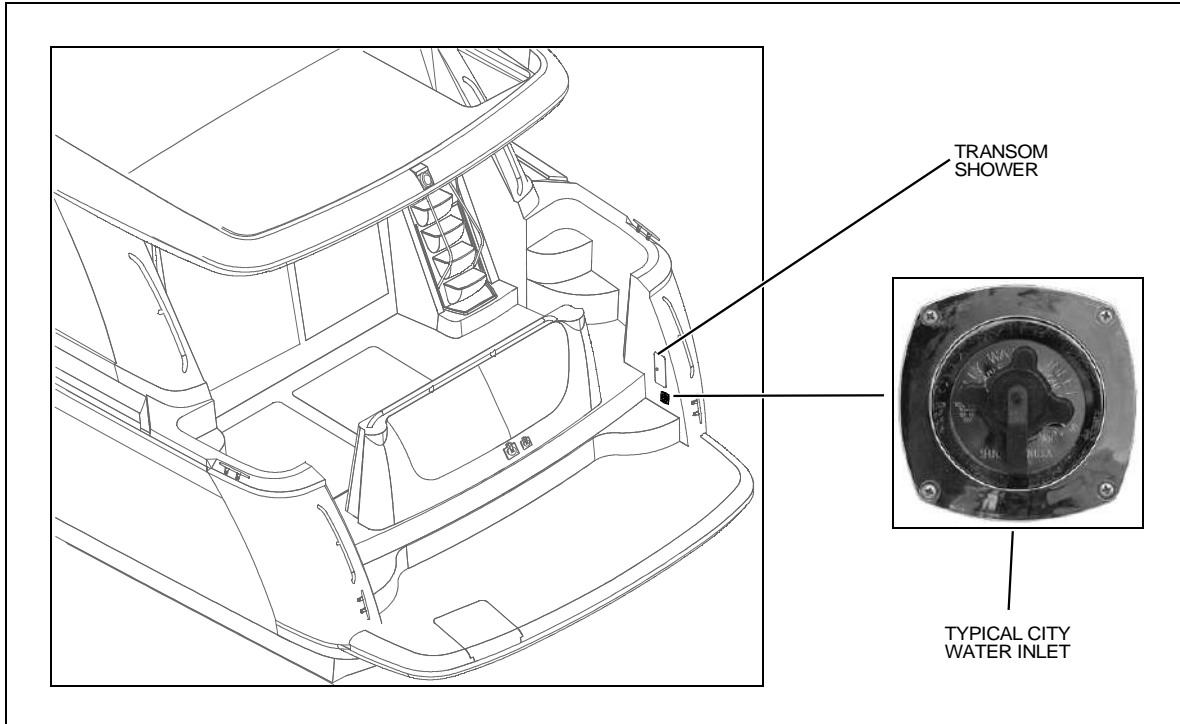

- Read the "City Water Hookup" portion of the *Freshwater System* section in the *Cruiser & Yacht Owner's Manual Supplement*.
- When the yacht is connected to a dockside water supply, the freshwater system is pressurized. You do **not** need to turn **On** the water pump's DC breaker, located on the DC panel.

Transom Shower

- Your yacht features a freshwater transom shower.
- Read the manufacturer's instructions **before** using the transom shower for the first time.
- The water pump switch **must** be turned **On before** using the transom shower.

Drain Systems

Deck Drains

- Water on the deck is drained overboard through the deck drains.
- Keep the deck drains free of debris.

Galley Sink Drain

The galley sink is gravity drained overboard.

Sump Pump Drain Systems

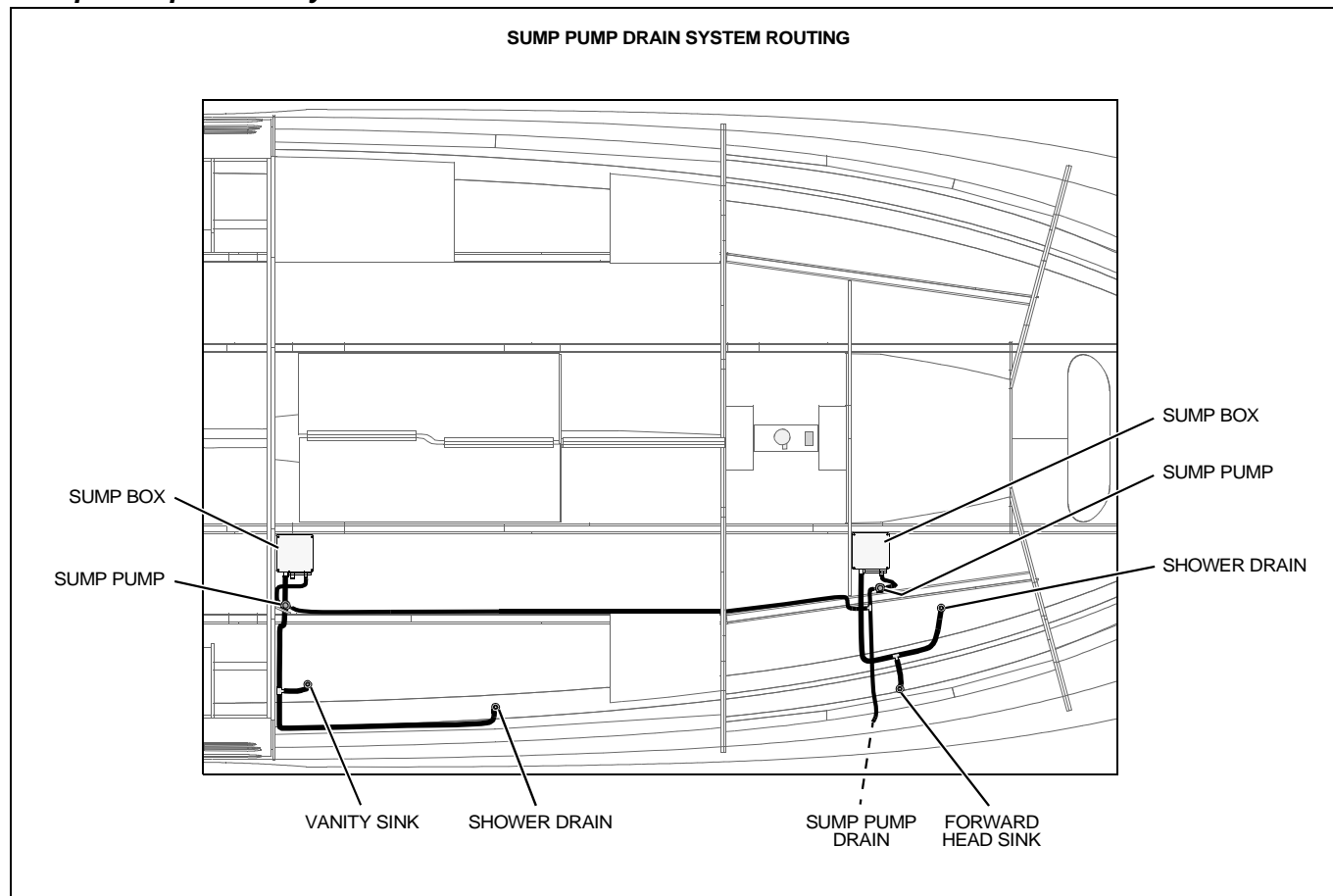

- The showers and head sinks drain into sump boxes.
- Each sump box has a float switch.
- When water rises to a preset level the float switch turns *On* a sump pump.
- The sump pump pumps the drain water overboard.

Sump Box Cleaning

Periodically clean the sump box (A), filter, and pump as follows:

1. Remove the cover screws (B) and the cover (C).
2. Remove any debris from the box and the filter.
3. Clean the sump pump as outlined in the Bilge Pump section of this *manual*.

Sump System Winterization

Drain the sump pump system in the winter months when *not* in use.

1. Disconnect and drain *all* lines to the unit.
2. Remove the screws from the mounting feet (D) and drain the system.
3. Reinstall the screws in the mounting feet and reconnect the system.

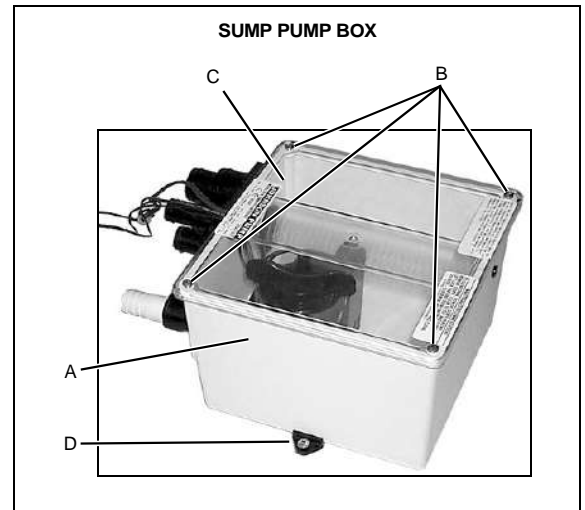

Marine Head with Holding Tank

NOTICE

Check with local authorities for regulations regarding the legal use of marine head systems.

Electric Head

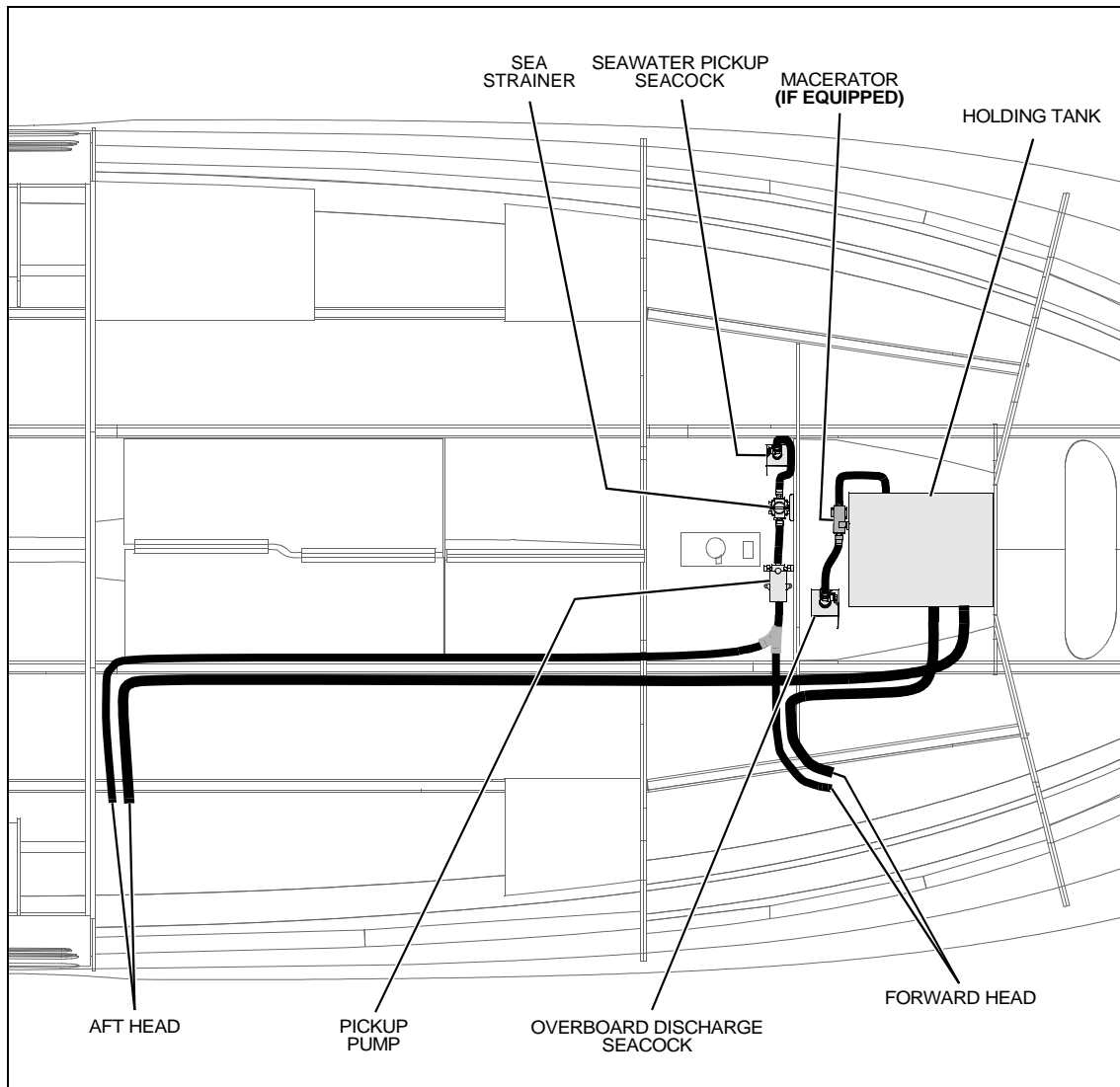

- Read the marine head operation and maintenance manual *before* using the marine head for the first time.
- The holding tank is plumbed to a waste fitting on the deck for dockside pump-out.
- Check the content level of the holding tank by looking at the side of the tank.
- Empty the holding tank at every opportunity.

Winterizing The Marine Head

1. Shut *Off* the intake seacock, and pump the head until the bowl is dry.
 2. Remove the drain plug in the base and pump again to remove *all* of the water.
- *Do not* fill the bowl with anti-freeze.
 - *Close* the intake seacock while the yacht is underway or whenever the yacht is left moored in the water.

Macerator (If Equipped)**NOTICE**

Check with local authorities for regulations regarding the legal use of marine head systems.

To use the macerator to pump waste directly into the water (where regulations permit):

1. **Open** the underwater discharge seacock.
2. Press both macerator switches at the same time to run the pump. **Do not** continue running the macerator if the waste holding tank is empty.
3. **Close** the underwater discharge seacock when you are done pumping.

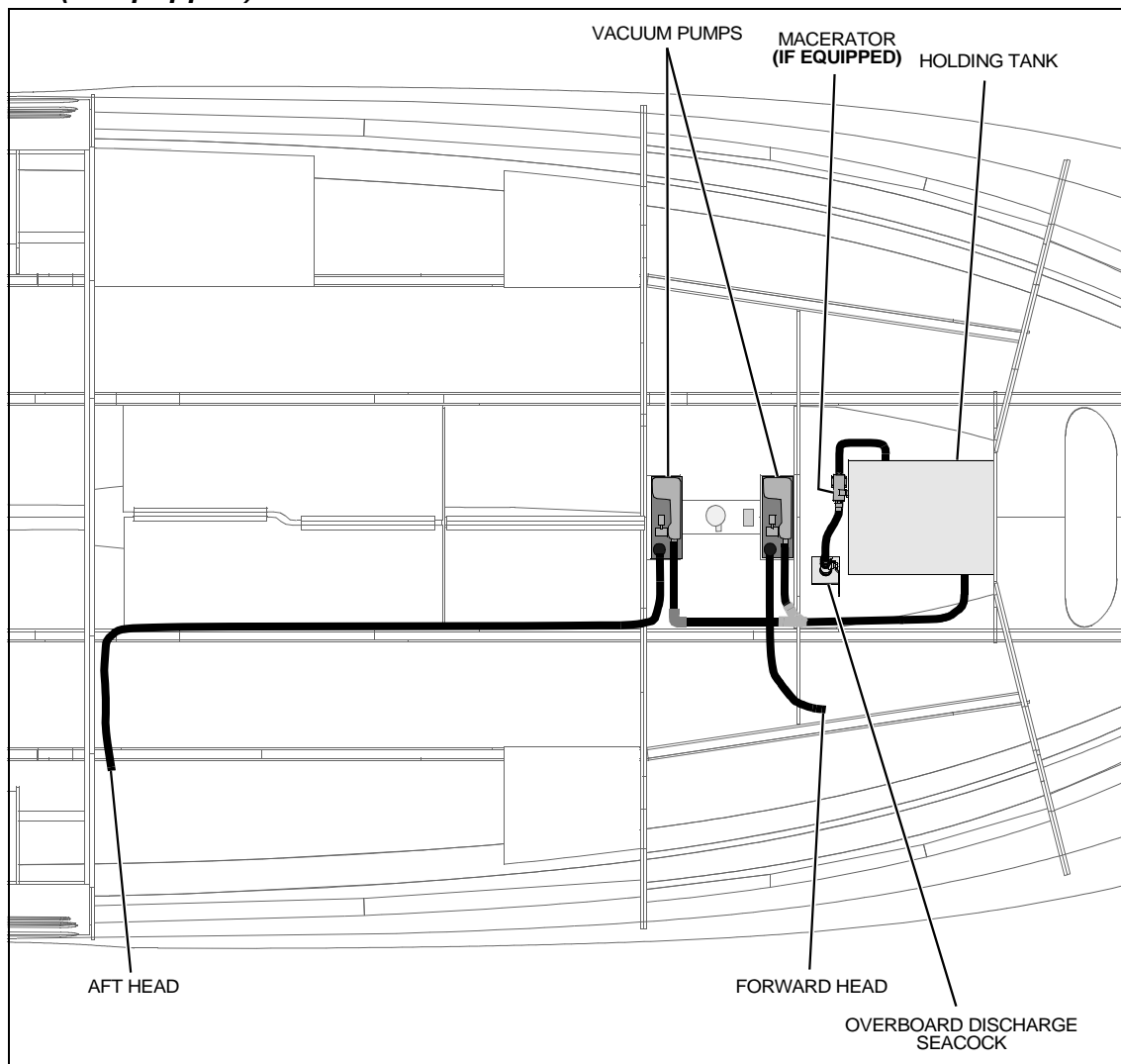
VacuFlush (If Equipped)

- The VacuFlush head system uses a vacuum pump, freshwater from the water tank and a vacuum generator to flush waste from the toilet into the holding tank.
- The holding tank is plumbed to a waste fitting on the deck for dockside pump-out.
- For winterizing instructions, refer to the VacuFlush head operation and maintenance manual.

Chapter 7: Deck Equipment

Cleats

 WARNING!
<p><i>PERSONAL INJURY and /or PRODUCT or PROPERTY DAMAGE HAZARD!</i></p> <ul style="list-style-type: none"> • <i>NEVER</i> lift the yacht using the cleats.

Carefully read the section on towing in the *Cruiser & Yacht Owner's Manual Supplement* **before** towing anything behind the yacht or having the yacht towed by another vessel.

Windlass (If Equipped)

 CAUTION!
<p><i>PRODUCT DAMAGE HAZARD!</i></p> <ul style="list-style-type: none"> • <i>DO NOT</i> pull the yacht to the anchor using the windlass or continue to run the windlass if it has stalled or is overloaded.

- Your yacht may feature an anchor windlass.
- Read and follow the manufacturer's instruction manual **before** using the anchor windlass for the first time.
- The windlass can be controlled from a switch at the helm or from the deck foot switches.
- Make sure that the windlass breaker is turned **On before** using the anchor windlass.
- To haul the anchor, use engine power (**not** the windlass) to move the yacht to, and directly above, the anchor.
- Use the windlass to dislodge the anchor from the bottom by pulling it straight up.

Davit (If Equipped)



WARNING!

PERSONAL INJURY and /or PRODUCT or PROPERTY DAMAGE HAZARD!

- Water is heavy. Lifting a dinghy to drain its bilge may exceed the davit's load limit.
- Also, use extreme care when using the davit in rough weather or sea conditions as the load may swing out of control.



WARNING!

PERSONAL INJURY, FALLING HAZARD!



- Falling from a suspended boat may cause injury or death.
- Do not allow passengers in a suspended boat.
- Davit load *not* to exceed 750 lbs.
- Only use the davit when it is securely locked in the upright position.

- ***Before*** using the davit read the davit's operating instructions and heed the warnings above.
- Make sure that the davit breaker is turned ***On before*** using the davit.

Canvas



CAUTION!

Take down and securely stow the canvas top, side curtains and back cover *before* transporting your yacht by road.

NOTE: SHOWN WITH OPTIONAL
SIDE CURTAINS INSTALLED

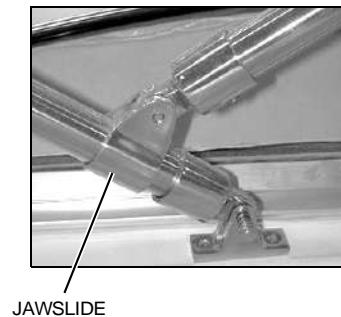
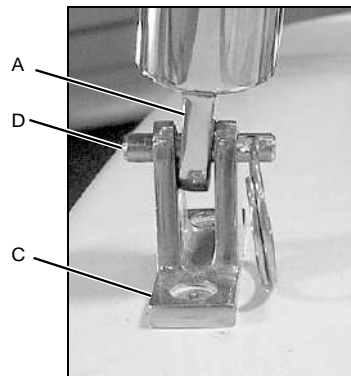

1. Insert the end eyes (A) of the main bow (B) into the deck hinges (C) and secure with the pins (D).
2. Pull the secondary bows (E) forward and insert the end eyes of the forward braces (F) into the deck hinges and secure with the pins.
3. Insert the end eyes of the aft braces (G) into the deck hinges on the hard top.
 - The jaw slides should *not* need to be adjusted.
 - However, if you think the jaw slides need to be adjusted, obtain the measurements from your selling dealer.

Chapter 8: Appliances & Entertainment Systems

NOTICE

Always keep an approved ABC-type fire extinguisher in galley area.

All appliances and entertainment systems installed on your yacht come with their own manuals. These manuals contain detailed instructions and important safeguards. Thoroughly read and understand these manuals *before* using your yacht's appliances and entertainment systems.

- Make sure the AC breaker is turned *On* for the appliance you wish to use.

Refrigerator

Your yacht features a 120-volt AC/12-volt DC refrigerator. The refrigerator runs on 12-volt DC power unless 120-volt AC power is being supplied by the shore power *and* the AC refrigerator breaker is *On*.

Electric Stove (If Equipped)



WARNING!



BURN/SCALDING and/or FIRE HAZARD!

- Read the stove's instruction manual *before* using.
- *Always* keep an approved ABC-type fire extinguisher in galley area.
- *Do not* use the stove while underway.
- Any non-cooking devices on or near your stove during use are potential fire hazards!
- **DO NOT** touch burners, grates or nearby surfaces as they may be hot even when they are dark in color. Areas near burners and grates may become hot enough to cause burns.
- During and after use, *do not* touch or let clothing or other flammable material come in contact with heated units or areas near the units (burner tops, main frame sides and back, sea rails and pot holders) until they have had sufficient time to cool.

Range/Oven

WARNING!

BURN HAZARD!

- *Do not* touch stove burners, grates or areas near the stove units as they may be hot even when they are dark in color. Areas near burners and grates may become hot enough to cause burns.
- During and after use, *do not* touch or let clothing or other flammable material come in contact with heated units or areas near the units (burner tops, main frame sides and back, sea rails and pot holders) until they have had sufficient time to cool.

Your yacht is equipped with an electric range/oven. *Before* attempting to use the range/oven, make sure the breaker switch on the AC master panel is *On*. Read and understand the instruction manual *before* using the range/oven.

Audio & Visual Equipment

NOTICE

AM radio reception may be impaired anytime the engine is running.

Dockside Television & Telephone Inlet

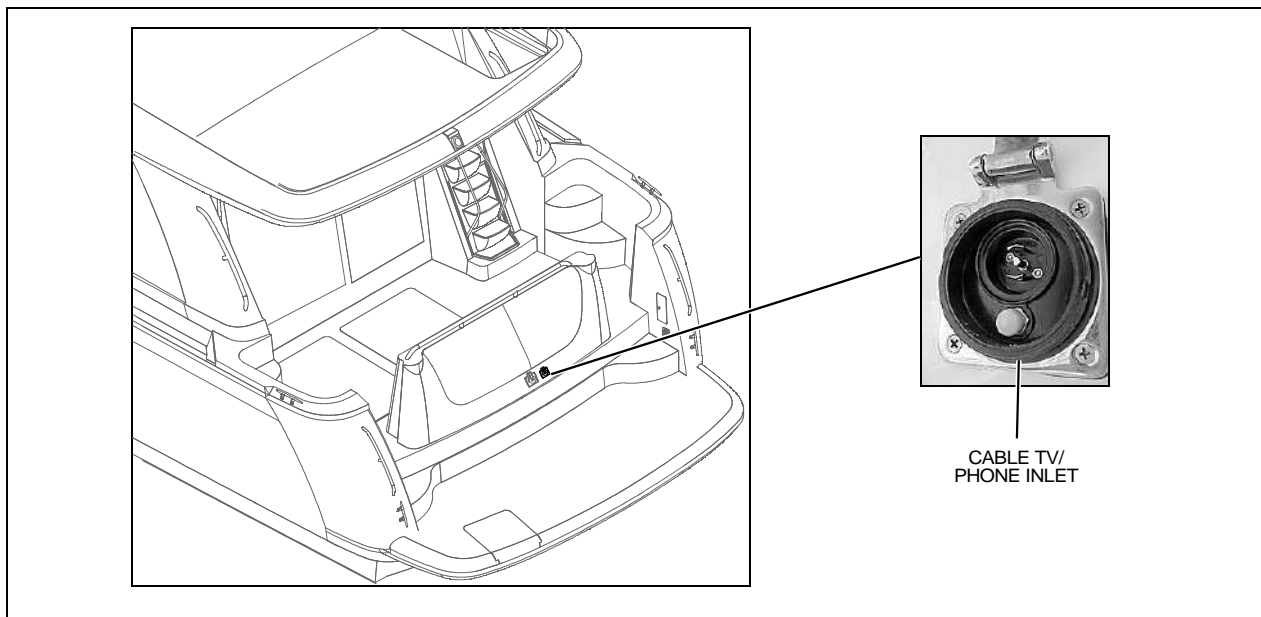

If you want to watch cable TV or use a telephone, plug a dockside source into the TV/telephone inlet.

Chapter 9: Lights

Care and Maintenance

All of the lights installed on your yacht are of top quality, but you should be aware that failure may periodically occur for a variety of reasons:

1. There may be a blown fuse - *replace the fuse.*
2. The bulb may be burned out - *carry spare bulbs for replacement.*
3. A wire may be damaged or may have come loose - *repair as required.*
4. The bulb base may be corroded - *clean the base and coat it with non-conductive electrical lubricant.*

Interior & Exterior Lights



CAUTION!

- **Be conservative in the use of battery power.**
- **Prolonged use of cabin interior lights (overnight) will result in a drained battery.**

- The lights are powered by the yacht's 12-volt DC system.
- The battery switch must be in the **On** position for the lights to work.
- There are **On/Off** light switches for different sets of lights on the cabin wall.
- Some individual lights also have a switch on the light.

Spotlight (If Equipped)

- Your yacht may feature a spotlight on the command bridge.
- The spotlight controls are located at the upper helm station.
- Read the spot light operating instructions **before** using the spotlight.

Chapter 10: Heating & Air Conditioning

Air Conditioning System (If Equipped)

⚠ DANGER!	
	<i>CARBON MONOXIDE POISONING HAZARD!</i>
	Dangerous carbon monoxide gas (CO) can be brought into the boat through the air conditioning system.

⚠ CAUTION!	
<i>SYSTEM DAMAGE HAZARD!</i>	
The air conditioning system's seacock <i>must</i> be <i>Opened before</i> turning on the air conditioner and <i>must</i> remain <i>Open</i> during use.	

Pilothouse Air Conditioning System

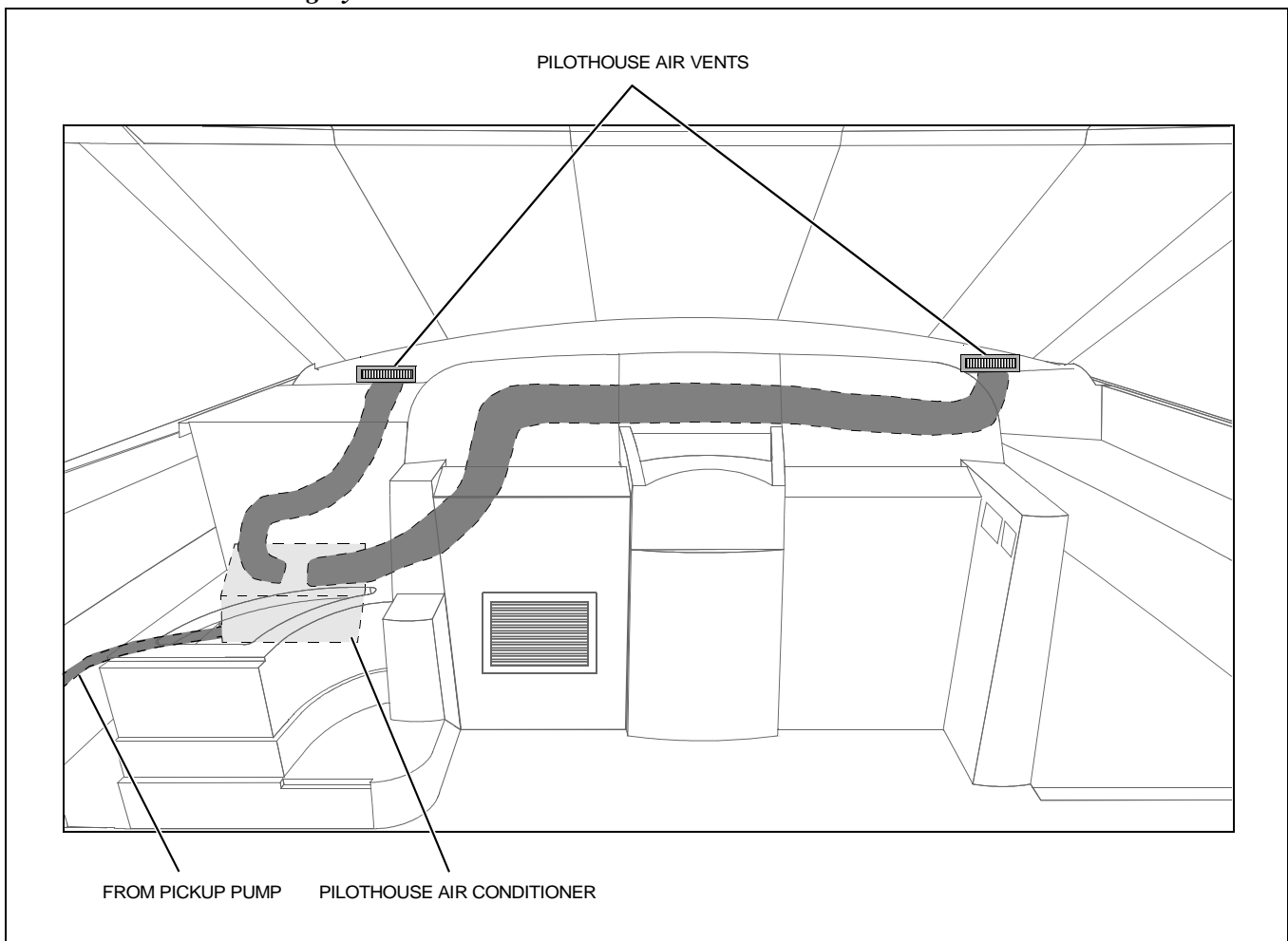

Forward & Aft Air Conditioning Systems

Read the air conditioner manual *before* using the air conditioning system.

- **Before** using the air conditioning system, make sure the breakers on the AC main distribution panel are turned **On** and that the system's seawater pickup seacock is **Open**.
- The seacock must remain **Open** while the air conditioner is in use.
- Check the seawater pickup strainer for debris **before** each use of the air conditioning system.
- If the strainer needs to be cleaned out; follow the directions given in the *Seawater Systems* section of this manual.

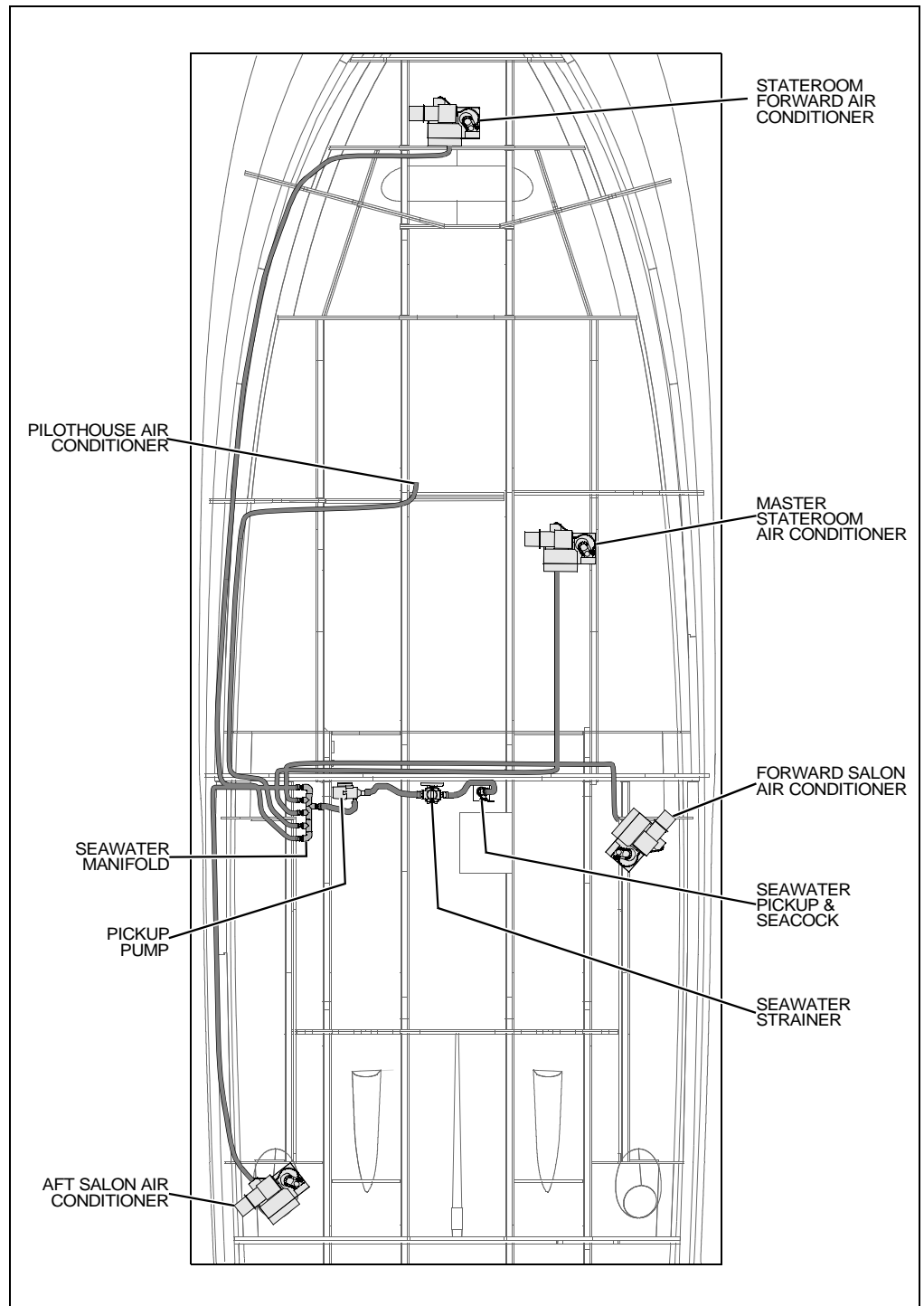

Diesel Heat (If Equipped)

⚠ DANGER!

CARBON MONOXIDE POISONING HAZARD!

Carbon monoxide gas (CO) is colorless, odorless, and extremely dangerous. All engines, generators, and fuel burning appliances produce CO as exhaust. direct and prolonged exposure to CO will cause *BRAIN DAMAGE* or *DEATH*.

- **Headache**
- **Nausea**
- **Dizziness**
- **Drowsiness**

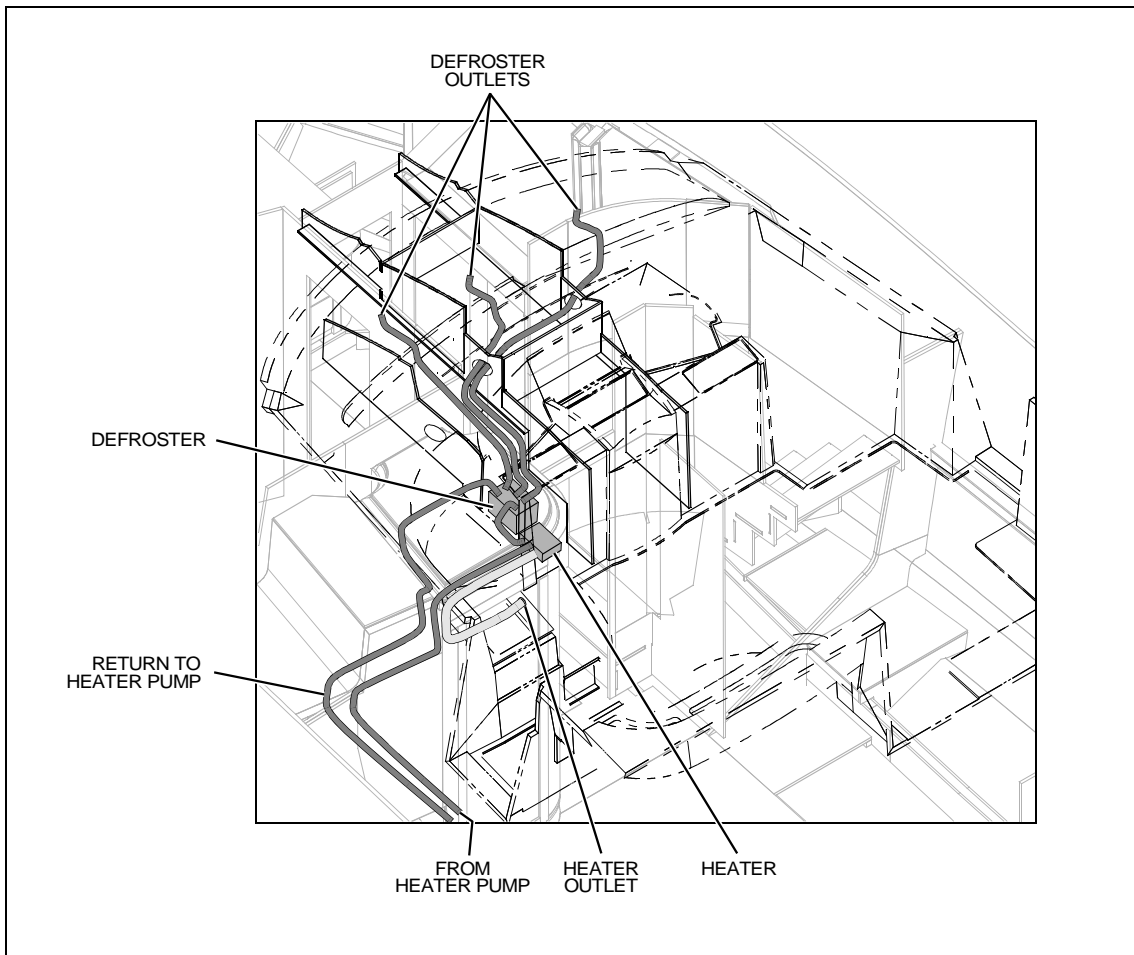

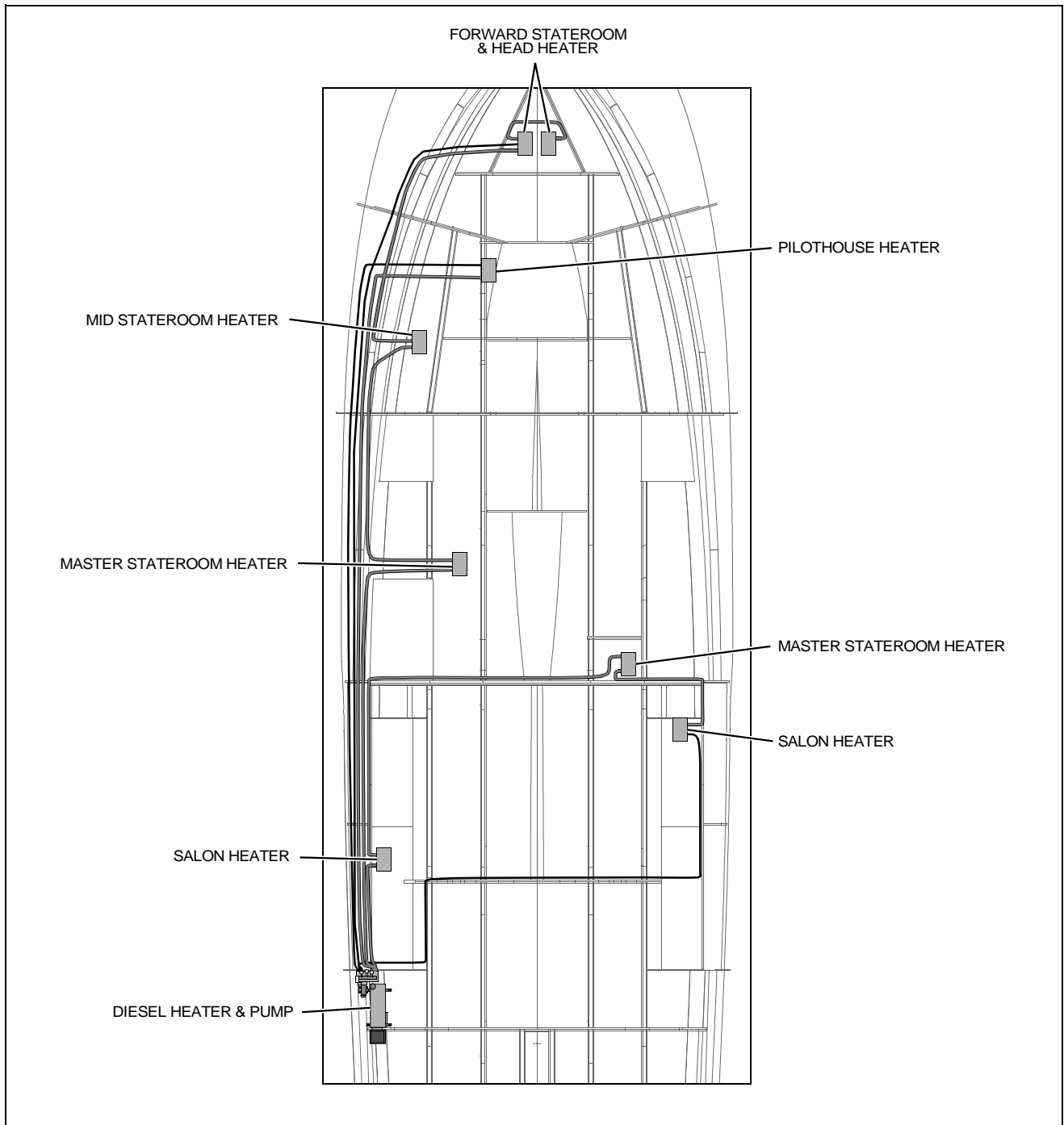



Electric Heaters (If Equipped)

Your yacht may feature electric cabin heaters. Operating instructions for this system can be found in the manufacturer's instruction manual.

- **Before** using the electric heaters, make sure the breakers on the AC panel are turned **On**.

Chapter 11: Electrical System





⚠ DANGER!

EXTREME FIRE, SHOCK & EXPLOSION HAZARD!

- To minimize the risks of fire and explosion, *NEVER* install knife switches or other arcing devices in the fuel compartments.
- *NEVER* substitute automotive parts for marine parts. Electrical, ignition and fuel system parts were designed and manufactured to comply with rules and regulations that minimize risks of fire and explosion.
- *DO NOT* modify the electrical systems or relevant drawings.
- Have qualified personnel install batteries and/or perform electrical system maintenance.
- Make sure that all battery switches are turned *Off before* performing any work in the engine spaces.

⚠ WARNING!

FIRE & EXPLOSION HAZARD!

- Fuel fumes are heavier than air and *will* collect in the bilge areas where they can be accidentally ignited.
- Visually and by smell (sniff test), check the engine and fuel compartments for fumes or accumulation of fuel.
- *ALWAYS* run the bilge blowers for at least four minutes prior to engine starting, electrical system maintenance or activation of electrical devices.
- Minimize the danger of fire and explosion by *not* exposing the batteries to open flame or sparks. *NEVER* smoke anywhere near the batteries.

⚠ CAUTION!



SHOCK & ELECTRICAL SYSTEM DAMAGE HAZARD!

NEVER disconnect the battery cables while the engine is running since it can cause damage to your yacht's electrical system components.

NOTICE

Electrical connections are prone to corrosion. To reduce corrosion caused electrical problems, keep *all* electrical connections clean and apply a spray-on protectant that is designed to protect connections from corrosion.

12-Volt DC System

Batteries

The batteries supply electricity for lights, accessories 12-Volt, and engine and generator starting.

The Electrical section of Chapter 8, in the *Cruiser & Yacht Owner's Manual Supplement*, provides battery, care and maintenance instructions.

Battery Switches



CAUTION!

- **Never disconnect the battery cables or turn *Off* the main battery switches while engines are running as this can cause damage to your boat's electrical components**

- A separate battery switch is provided for each battery (or battery bank).
- The batteries supply electricity for lights, 12-Volt accessories, and engine and generator starting.
- "Stand-by loads", such as the automatic bilge pumps, and the stereo memory, are *not* affected by the battery switches. Stand-by loads bypass the battery switch and are wired directly to the battery.

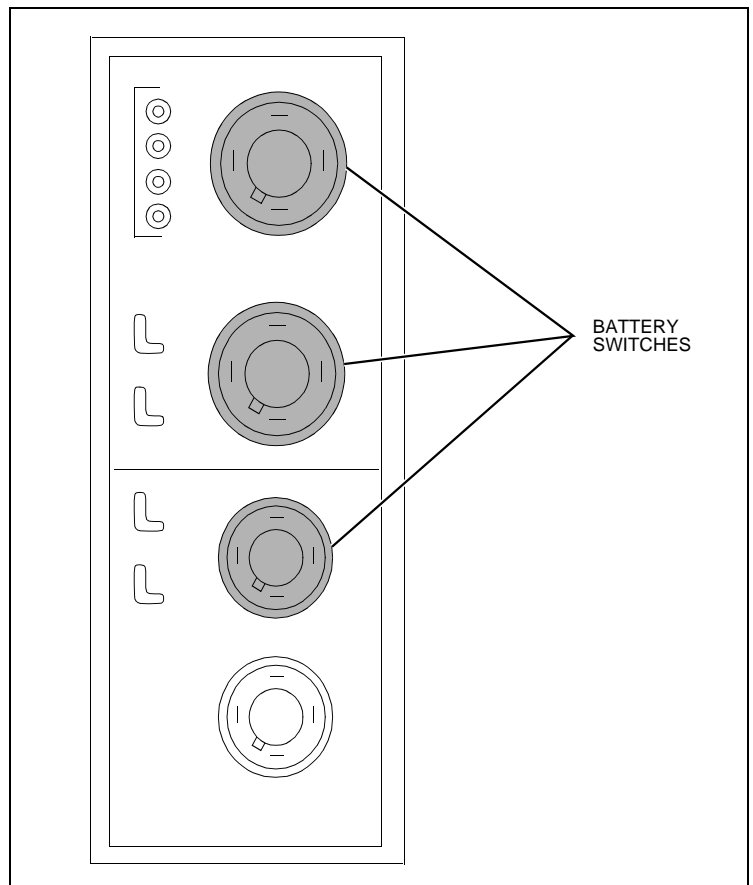

Fuses and Circuit Breakers

- Fuses and circuit breakers for engines and main accessory power are on the DC distribution panels and on the battery switch panel.
- Some equipment may have secondary fuse protection at the unit, behind the battery management panel or at the batteries.
- Electronics power is provided at the helm station.

12-Volt Accessory Outlet(s)

 CAUTION!
<p>DO NOT use the 12-volt accessory outlet with a cigarette or cigar lighter. High temperatures may melt the outlet.</p>

- Your boat features one or more 12-volt accessory outlets.
- The outlet can be used with any 12-volt device which draws 15 amps or less.
- The 12-volt accessory outlet is protected by a 15 amp circuit breaker on the main circuit breaker panel.

Alternators

The engine alternators *will* keep the batteries properly charged when running at cruising speeds.

Battery Charger or Inverter/Charger

 CAUTION!
<p>The battery charging systems (alternator and battery charger or inverter/battery charger) installed on your yacht are designed to charge conventional lead-acid batteries. Before installing gel-cell or other new technology batteries, consult with the battery manufacturer about charging system requirements.</p>

- **Before** using the battery charger or the inverter/battery charger, read **all** instructions and cautionary markings on (1) the battery charger or the inverter/battery charger, (2) the batteries, and (3) **all** appropriate sections of the battery charger manual or the inverter/battery charger manual.
- The battery switches **do not** need to be **On** when using the battery charger or the inverter/battery charger.
- You may use DC powered electrical systems, such as the lights and stereo when the battery charger or the inverter/battery charger is **On**, but there **will** be a corresponding drop in charger performance.

Alternating Current (AC) System

CAUTION!

WATER HEATER DAMAGE HAZARD!

- **DO NOT** turn *On* the water heater AC panel electrical circuit until the water heater tank is **COMPLETELY** filled with water.
- The tank is full if water flows from the tap when the hot water is turned *On* in the galley.
- Even momentary operation in a dry tank *will* damage the heating elements.
- Warranty replacements **WILL NOT** be made on elements damaged in this manner.

NOTICE

Whether using shore power or generator power, the simultaneous use of several AC components can result in an overloaded circuit. It may be necessary to turn *Off* one or more accessories in order to use another accessory.

- The 120V/60Hz AC system can be energized by shore power.
- The master circuit breakers, located on the AC panel, provide power source selections to AC powered accessories. Individual breakers *must* be turned *On* to supply power to the accessories you wish to use.
- The AC panel may contain inactive circuit breakers for accessories that are *not* available for this model yacht.

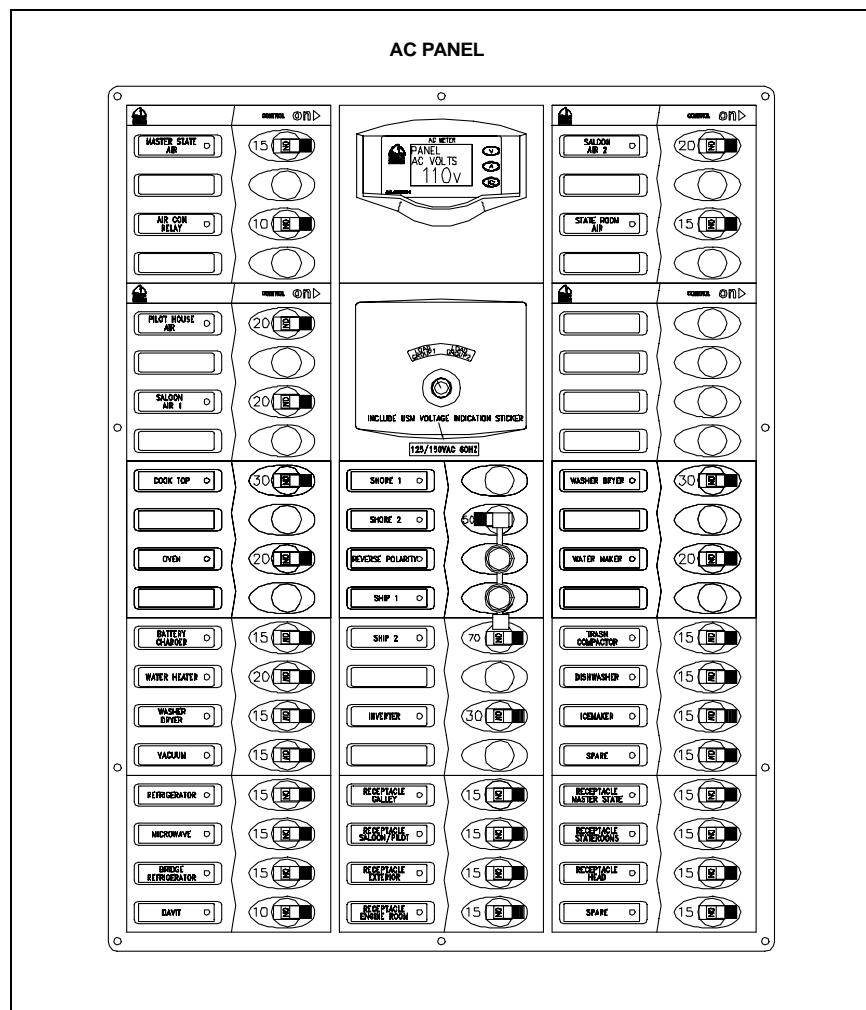

Shore Power



DANGER!



FIRE, EXPLOSION & SHOCK HAZARD!

- **DO NOT** alter shore power connectors and use *only* compatible connectors.
- **Before** plugging in or unplugging the shore power cord to your boat, make sure *all* breakers and switches on the AC master panel are turned *Off*.
- To prevent shock or injury from an accidental dropping of the “hot” cord into the water, **ALWAYS** plug the shore power cord to the boat inlet first; then to the dockside outlet. When unplugging from shore power, unplug the shore power cord from the dockside outlet first.
- **NEVER** leave a shore power cord plugged in to the dockside outlet only.
- Only use shore power cords approved for marine use. **NEVER** use ordinary indoor or outdoor extension cords that are *not* rated for marine use.



WARNING!



SHOCK & ELECTRICAL SYSTEM DAMAGE HAZARD!

- Monitor the polarity indicator lights **EVERY TIME** you connect to shore power.
- If a reversed polarity light turns on when you are connecting to shore power, **DO NOT turn On** the main breaker switches.
- Instead, **IMMEDIATELY** unplug the shore power cord (**ALWAYS** from the dockside outlet first) and alert marina management.



WARNING!



SHOCK & ELECTRICAL SYSTEM DAMAGE HAZARD!

- **Before** each use, check the shore power cord(s) for defects or damage.
- **NEVER** use damaged or faulty cords since the danger of fire and electrical shock exists.
- **DO NOT** pinch shore power cords in doors or hatches, or coil the shore power cord too tightly since these situations can generate enough heat to result in a fire.
- If a shore power cord is dropped into the water, **THOROUGHLY** dry the blades and contact slots *before* using.



CAUTION!



ELECTRICAL SYSTEM DAMAGE HAZARD!

- **NEVER** connect to dockside power outside of North America unless you have purchased the international electrical conversion option.
- Using several AC components at the same time can result in an overloaded circuit. You may have to turn *Off* one or more appliances in order to use another appliance.
- Use double insulated or three-wire protected electrical appliances whenever possible.



NOTICE



- Some dockside outlets may be rated less than 30 amps, therefore, you may need to purchase lower amp adapters.
- Whenever a lower amp adapter is used, however, there will be a corresponding drop in supplied power from the dockside system.

Inverter Power (If Equipped)

- The inverter allows the batteries to supply AC power to some accessories when your yacht is *not* connected to shore power.
- Primary control is from the Inverter Remote Control Panel and redundant controls are on the inverter itself.
- **Before** using the inverter, read *all* instructions and cautionary markings on (1) the inverter, (2) the batteries, and (3) *all* appropriate sections of the inverter manual.
- Energize the AC system under inverter power by switching **On** the inverter master breaker and pressing the **On/Off** switch on the inverter control panel.
- The inverter provides AC power only to the accessories that have white breakers on the AC panel.

Generator (If Equipped)

 DANGER!	
 DANGER <small>CARBON MONOXIDE</small>	<i>CARBON MONOXIDE POISONING HAZARD!</i>
	<ul style="list-style-type: none"> • Generators are a source of dangerous carbon monoxide gas (CO). Check the generator exhaust system for leaks before each use.

 WARNING!	
	<i>FIRE/EXPLOSION HAZARD!</i>
	<ul style="list-style-type: none"> • Use the bilge blowers for a minimum of four minutes <i>before</i> starting the generator. • Leave the blowers on while the generator is running unless the boat is running at cruising speed. • Use of the blower system is <i>not</i> a guarantee that explosive fumes have been removed. • If you smell any fuel, DO NOT start the generator. • If the generator is already running, IMMEDIATELY shut <i>Off</i> the generator and <i>all</i> electrical accessories and investigate. • DO NOT obstruct or modify the ventilation system.

 CAUTION!	
<i>SYSTEM DAMAGE HAZARD!</i>	
<ul style="list-style-type: none"> • <i>Always</i> make sure the generator's seawater pickup seacock is <i>Open before</i> and during the running of the generator. • NEVER use the generator starter for more than 30 seconds. • If the generator does <i>not</i> start, wait at least 30 seconds <i>before</i> another start attempt is made. • After starting the generator, wait for the generator to stabilize <i>before</i> turning <i>On</i> component breakers on the AC panel. 	

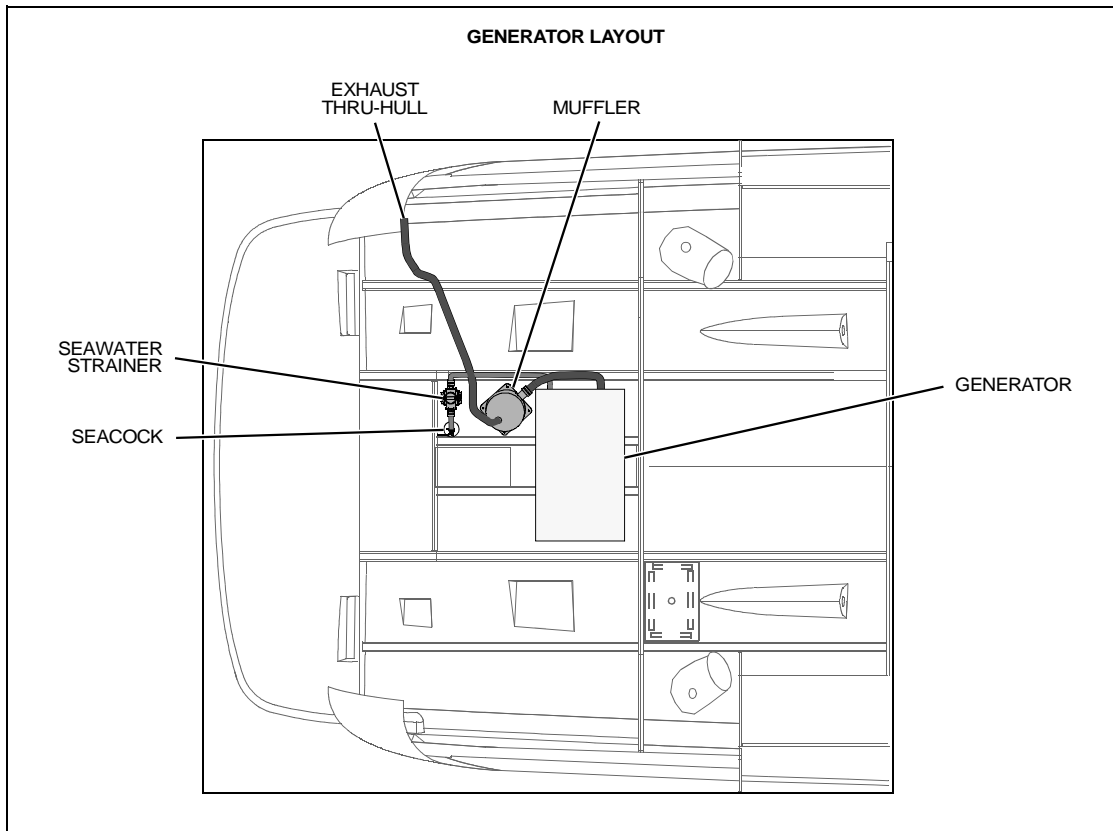

- The generator can supply 120V/60Hz power to the yacht when it is **not** connected to shore power.
- **Before** using the generator, read the generator operation manual for pre-start checks and break-in procedures.

Note the following about the generator:

- Polarity has been established in the installation of the generator, therefore the polarity lights **will not** function in this mode.
- Fuel to run the main generator is supplied from the port fuel tank.
- In addition to servicing the filters attached to the generator, the filters/separators (located near the fuel line valves) should be serviced as described in the manufacturer's manual.
- The coolant mixture installed at the factory consists of equal parts of water and antifreeze (Ethylene Glycol).
- The coolant bottle for the generator is located inside the port generator compartment hatch.
- Check the generator's seawater strainer for leaks and/or debris **before** each use.
- Oil pressure, water temperature, and voltage gauges are provided on the generator control panel, inside the AC/DC cabinet on the port side of the salon. These gauges monitor the engine functions of your generator.

Generator Starting & Stopping

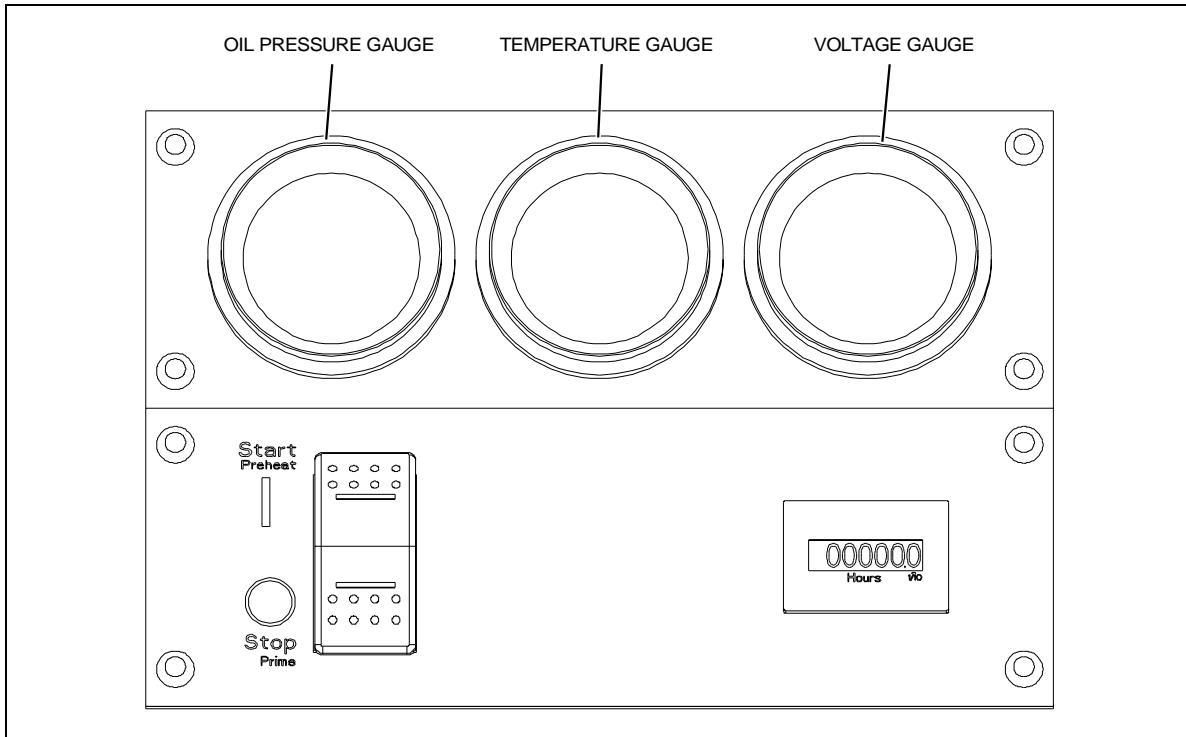

1. Run the bilge blowers for a minimum of four minutes *before* starting the generator.
 - If your yacht is running below cruising speed, leave the blowers on while the generator is running.
2. Make sure the generator's seawater pickup seacock is *Open before* starting and during running of the generator.
3. Make sure that the port engine battery switch is turned to the *On* position.
4. On the panel, hold the oil pressure switch (labeled "START/PREHEAT") until the generator starts.
5. Turn *On* each individual component breaker as required.

To shut *Off* the generator, hold the "STOP/PRIME" switch until the generator completely shuts down.

Electrical Routings

Deck Electrical Harness

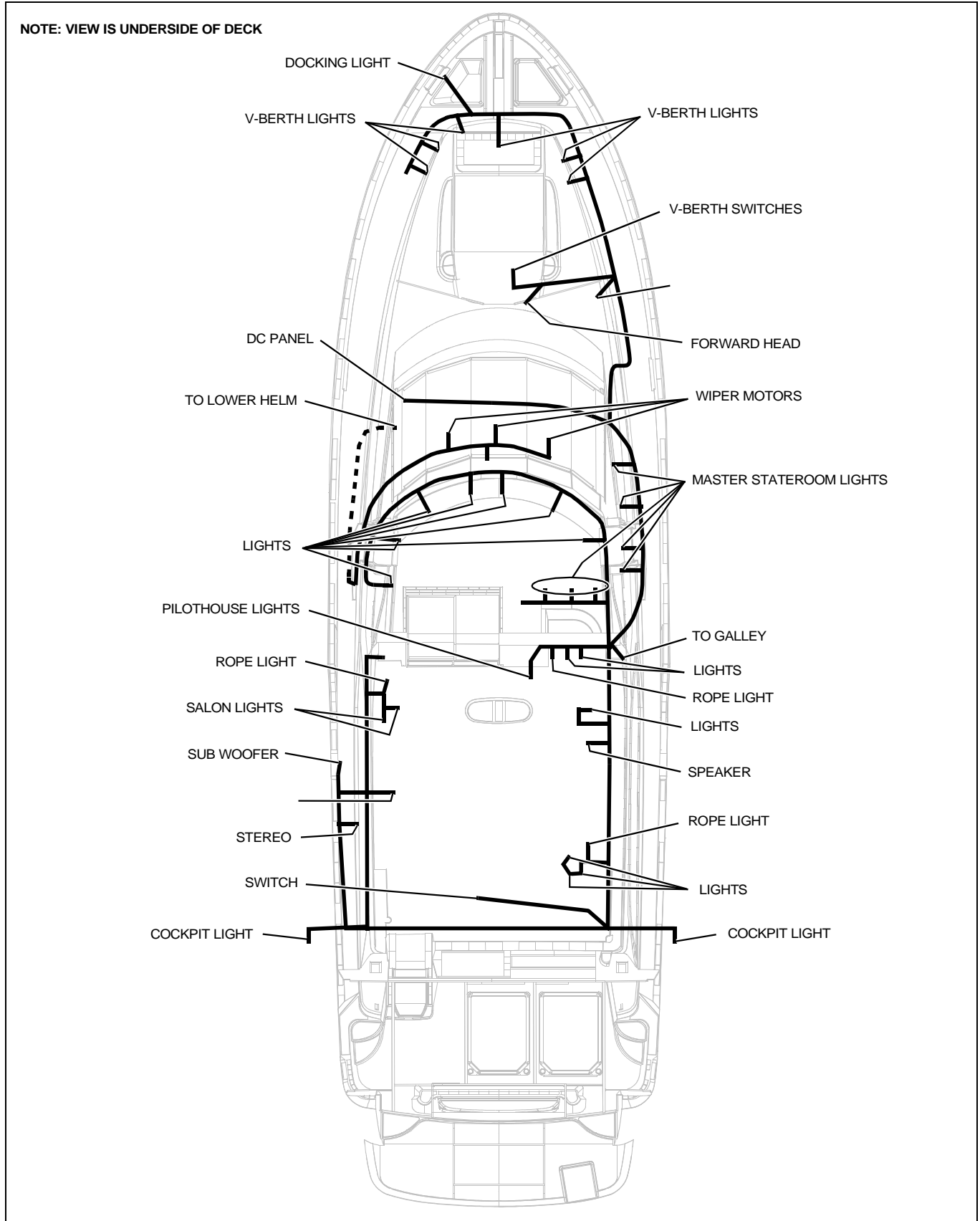

Hull Electrical System

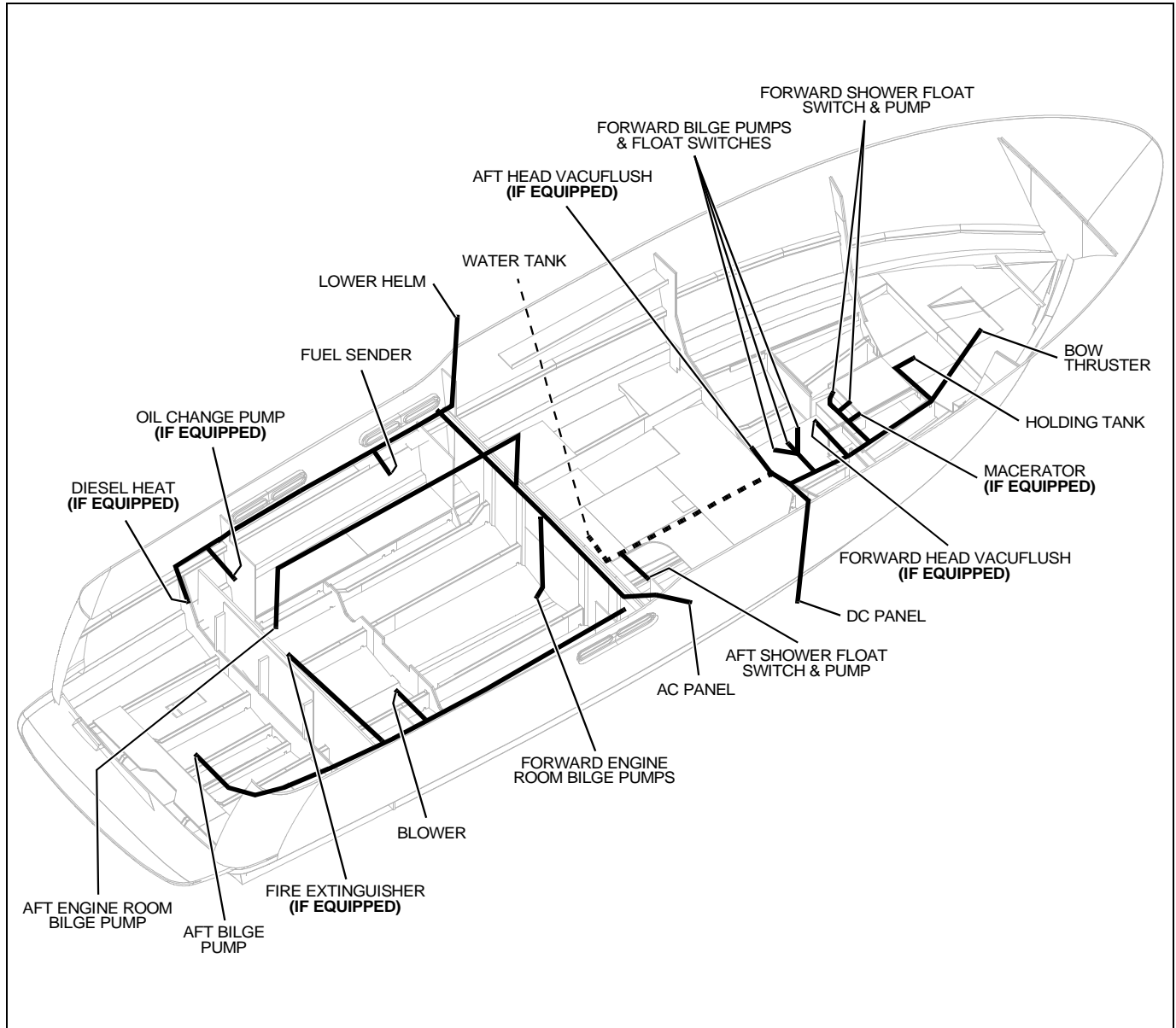

Radars Wing Harness

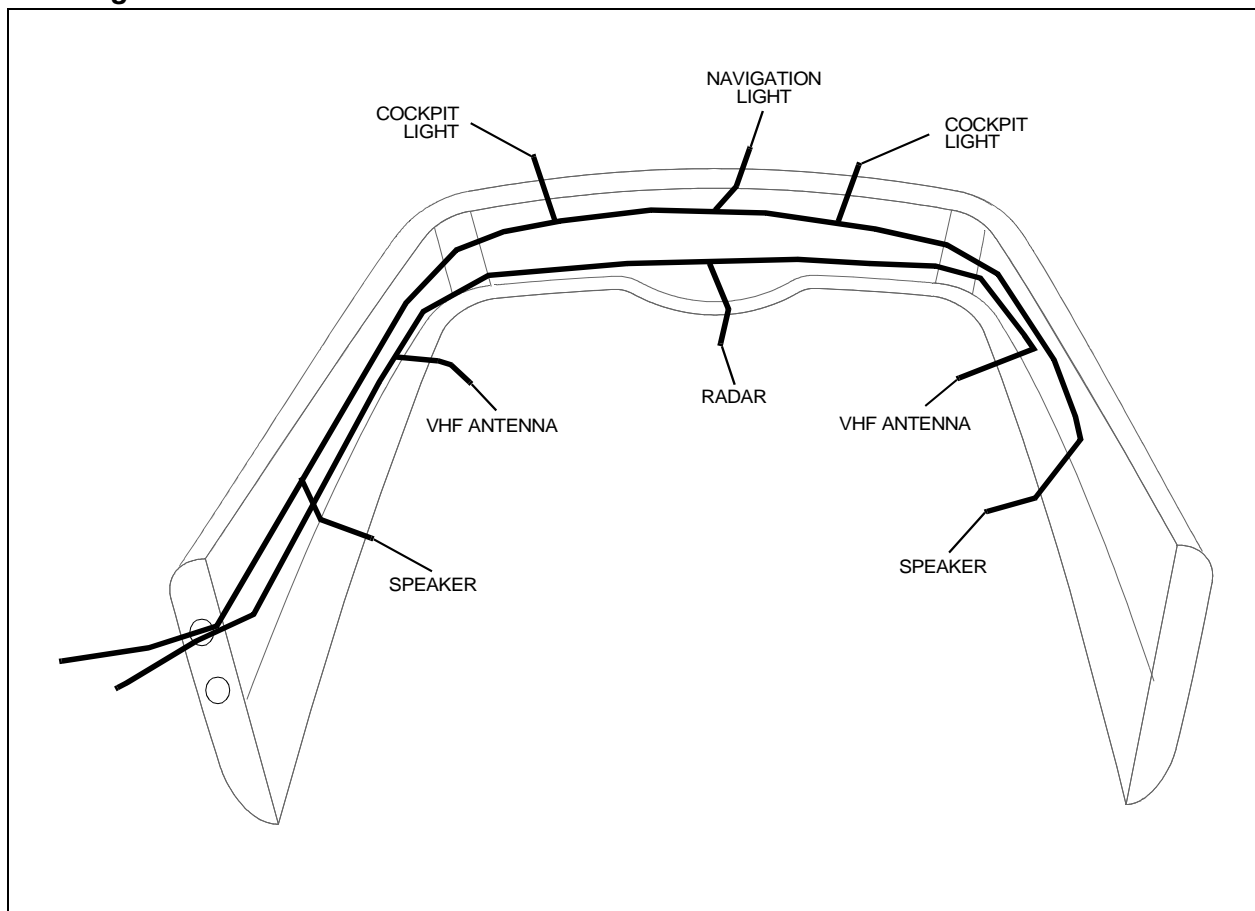

Command Bridge Shell Harness

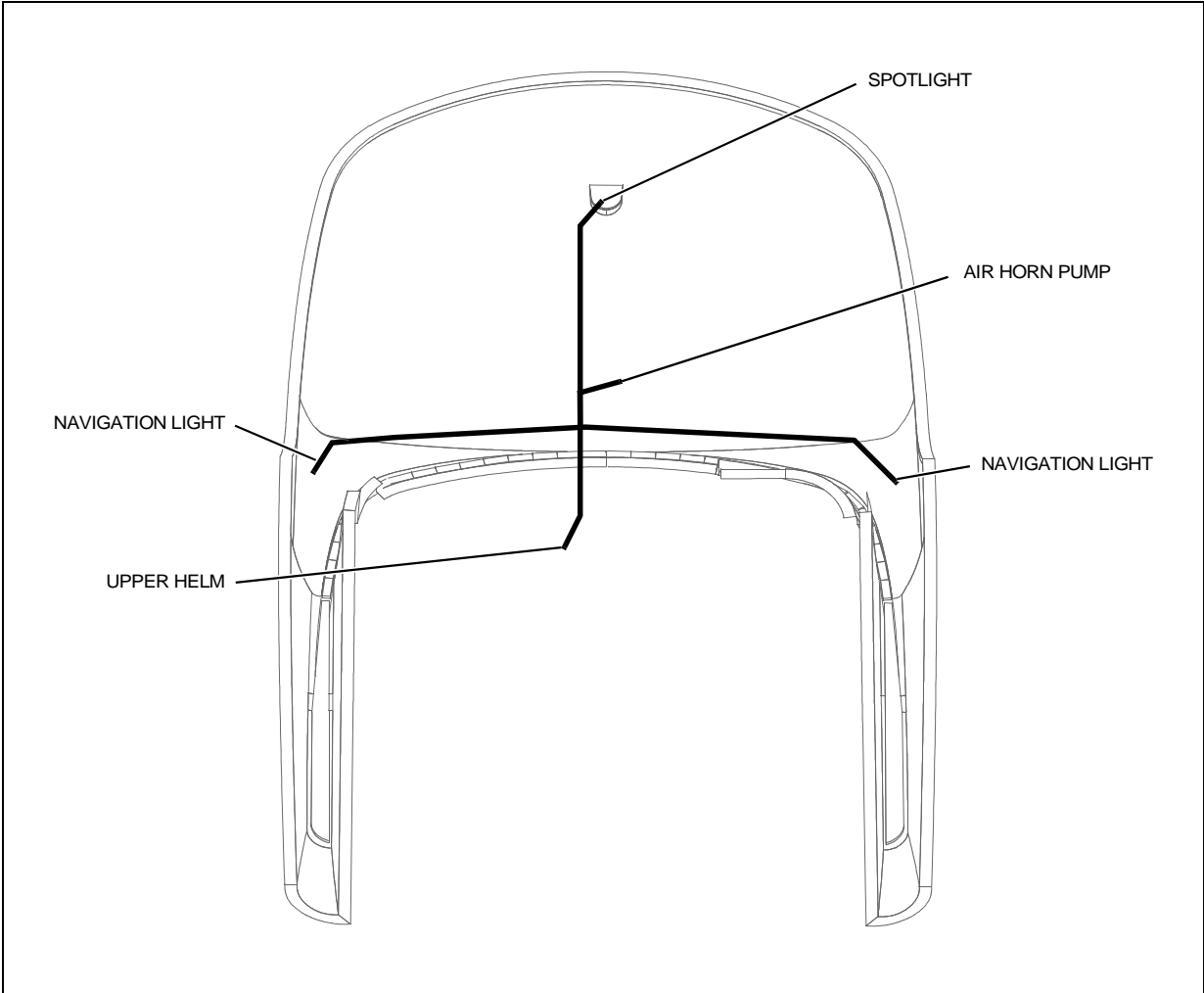

Battery Cable Routing

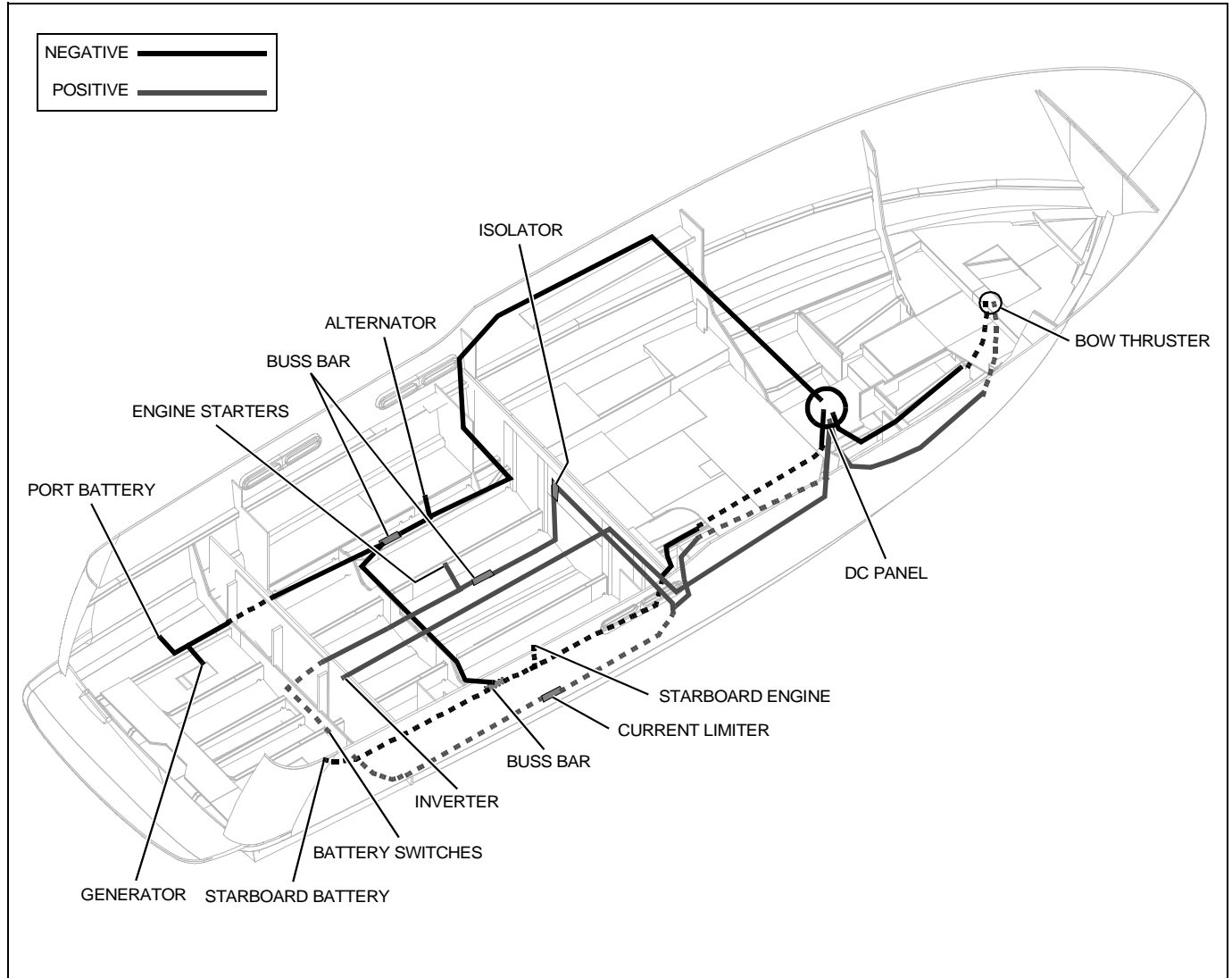

Battery System

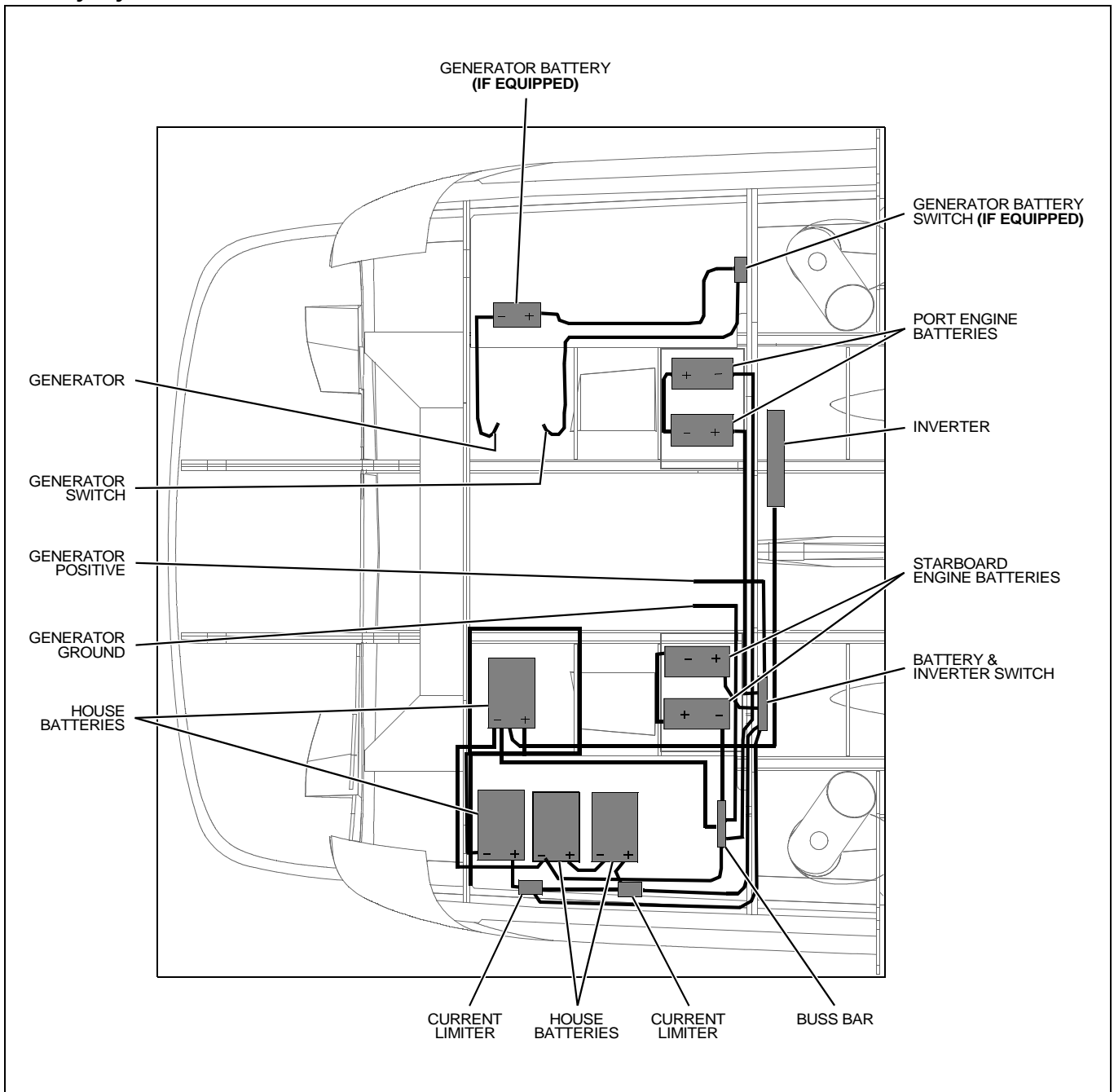



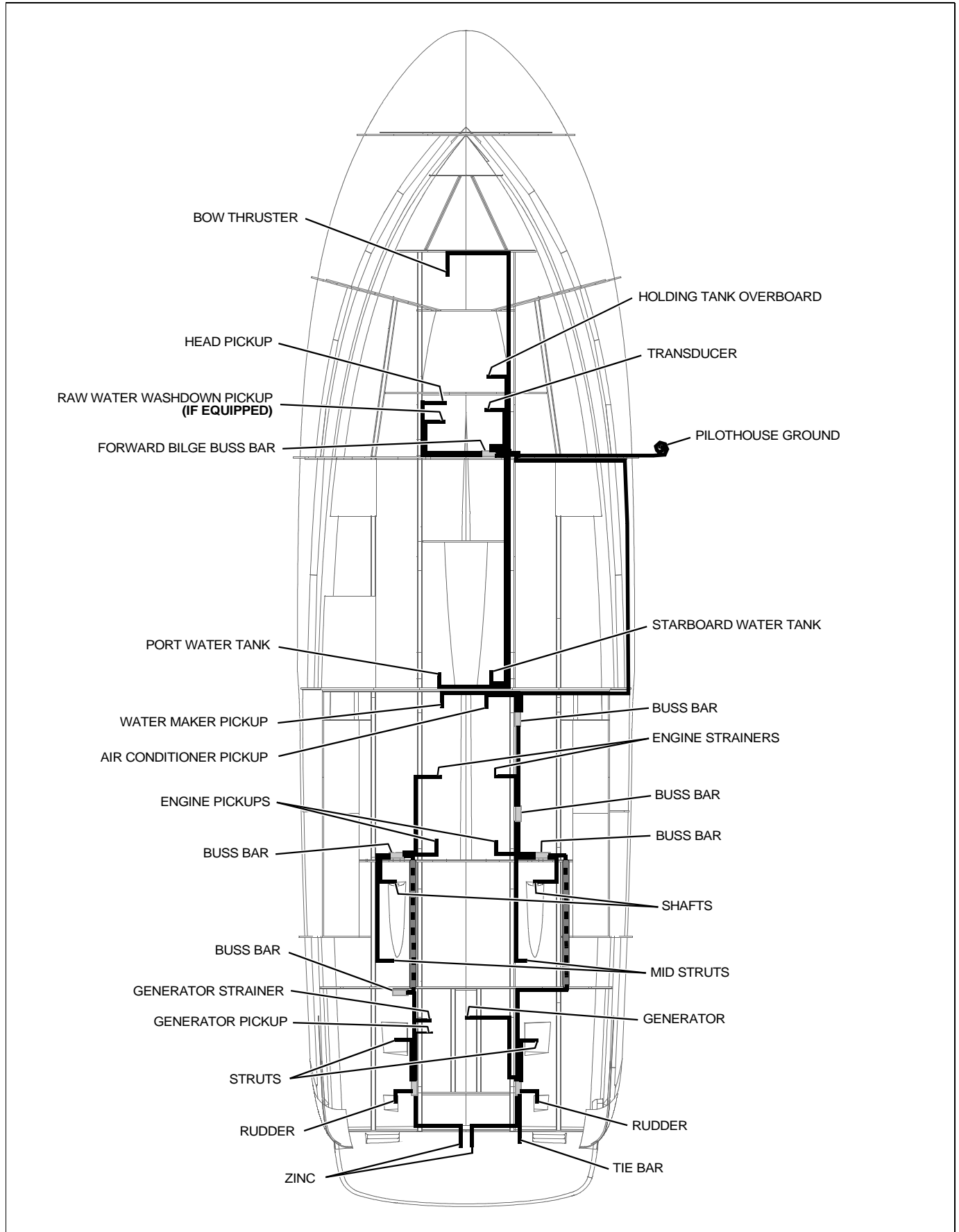





















Bonding Harness



Wiring Diagrams

Electrical Symbol Key

Symbol	Description	Symbol	Description
	Connection (Node)		Fuel Sender
	No Connection		Incandescent Lamp
	Battery		Neon Lamp
	Earth Ground: Represents a black conductor that is the same size as the colored conductor		Diode
	Ammeter		12V DC Receptacle
	Frequency Meter		Voltmeter
	Plug		Motor/Pump
	Breaker		Current Transformer
	Breaker		Solenoid
	Fuse		Gauge
	Switch: Single Pole Single Throw (SPST)		Speaker/Horn/Alarm
	Switch: Double Pole Single Throw (DPST)		Float Switch
	Lighted Switch: Single Pole Single Throw (SPST)		

Wire Color Key

Color Key	Description	Color Key	Description
B or BLK	Black	O, OR or ORG	Orange
BL or BLU	Blue	PK	Pink
BR or BRN	Brown	PU, PUR or PPL	Purple
DK	Dark	R or RED	Red
GY or GRY	Gray	T or TAN	Tan
G, GR or GRN	Green	W, WH or WHT	White
LT	Light	Y or YEL	Yellow

NOTICE

- Wiring diagrams may show *optional* equipment not installed on all models.
- Some yachts may come equipped with silver (-) and copper (+) colored speaker wires or red/black (-) and red/white (+) port speaker wire colors; green/black (-) and green/white (+) starboard speaker wire colors.

Smartcraft Electrical System

- NOTES:
 (1) CONTINUES TO OR FROM ANOTHER PAGE.
 (2) (DELETED)
 (3) START CIRCUIT NEUTRAL SAFETY SWITCHES LOCATED ON TRANSMISSIONS.
 (4) OPTIONAL EQUIPMENT.

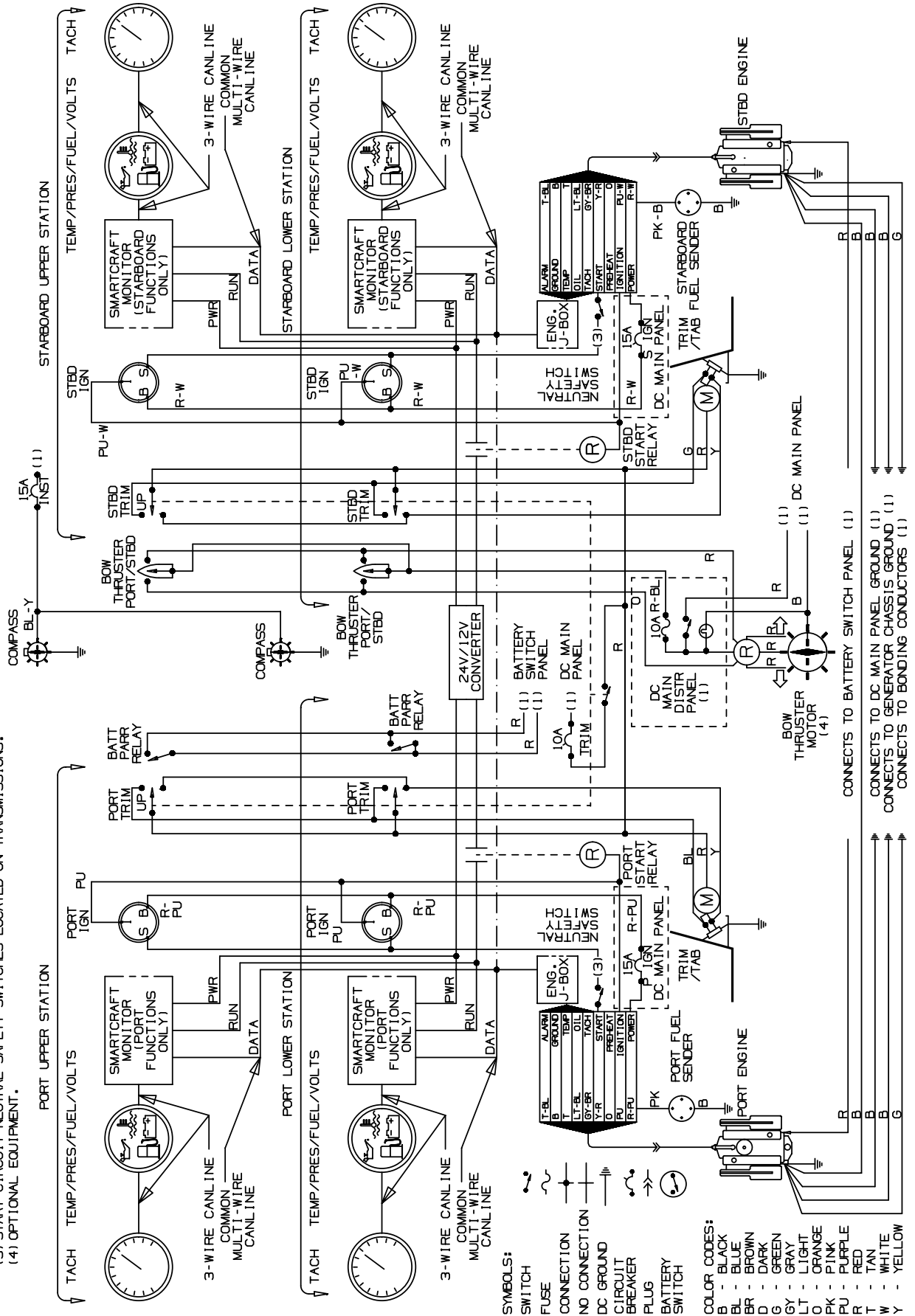

Hull Harness

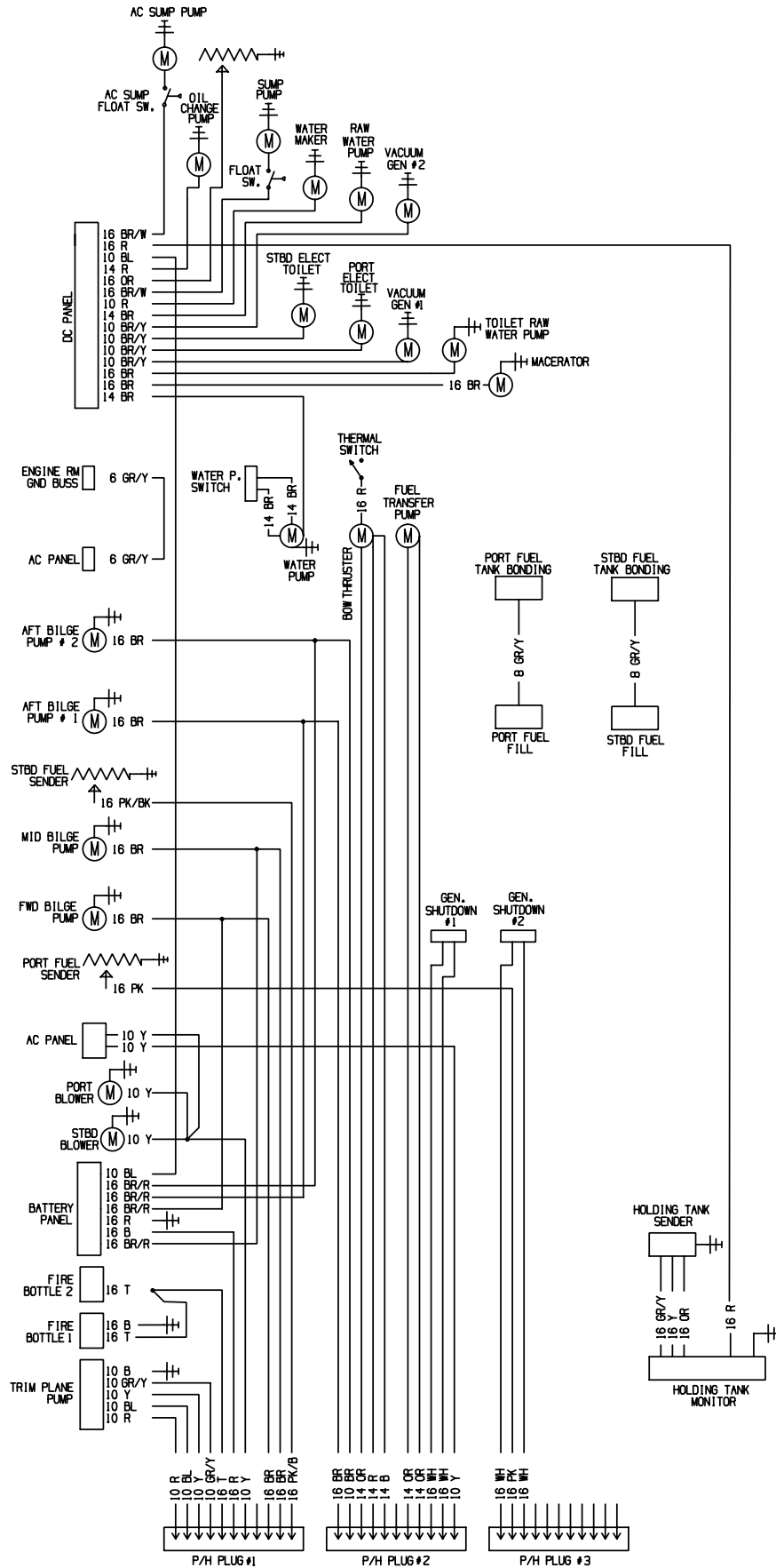

Pilothouse Harness

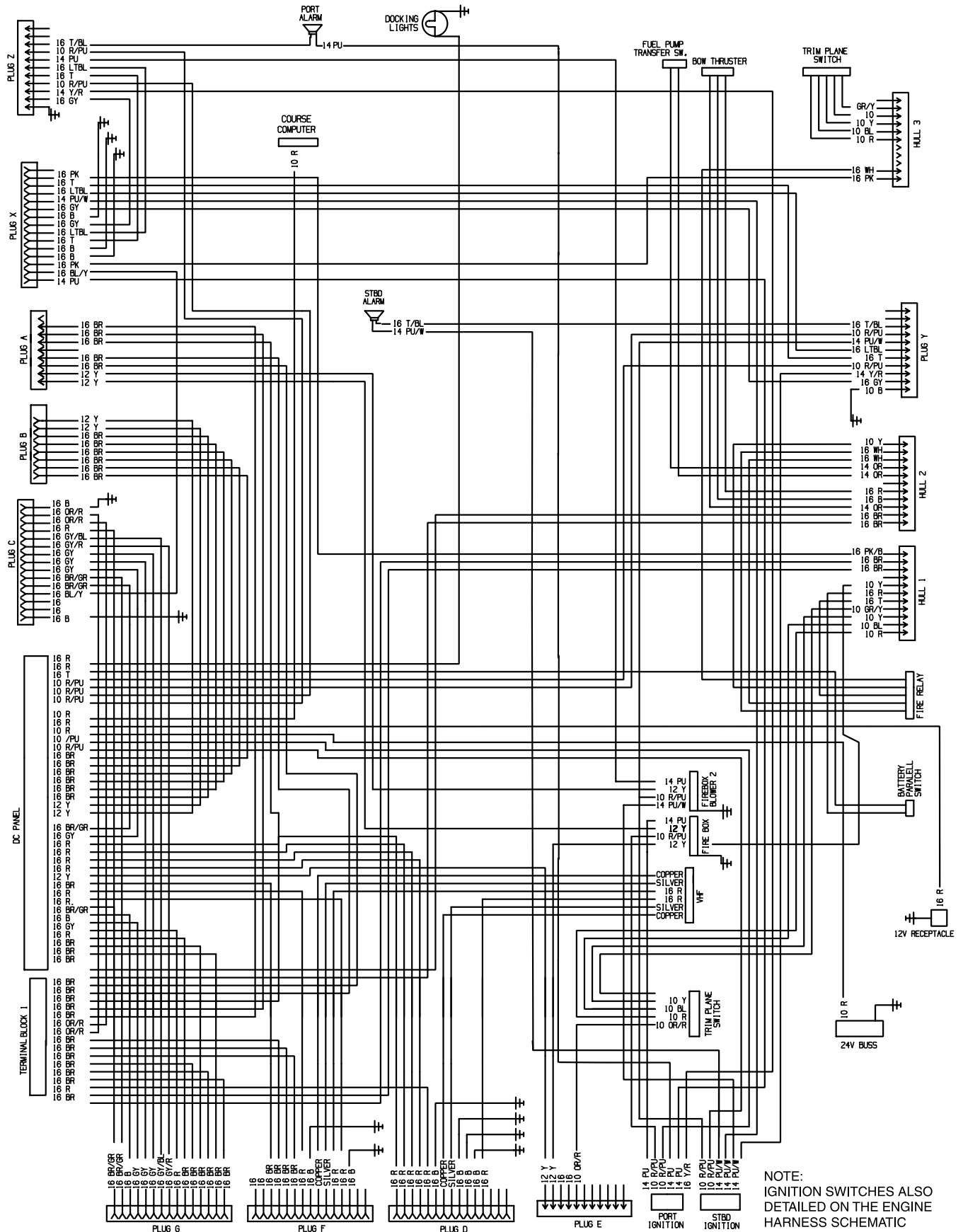

V-Berth Harness

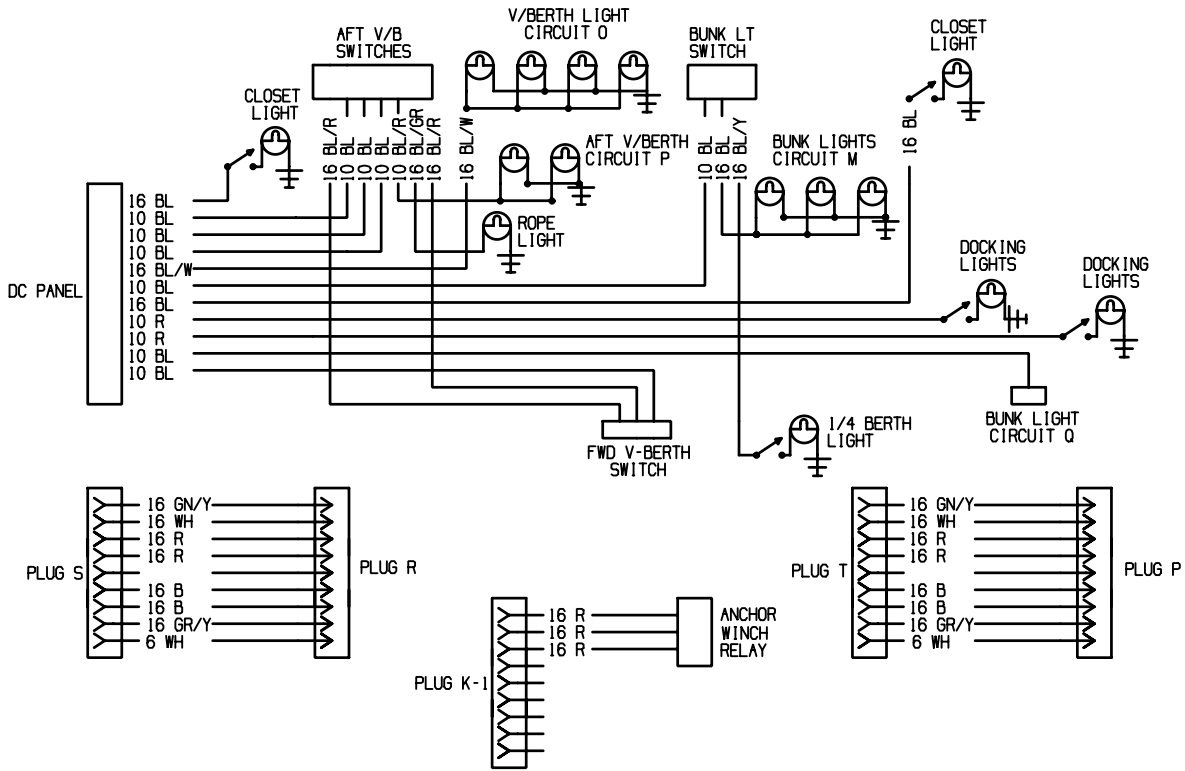

Diesel Heater (Option)

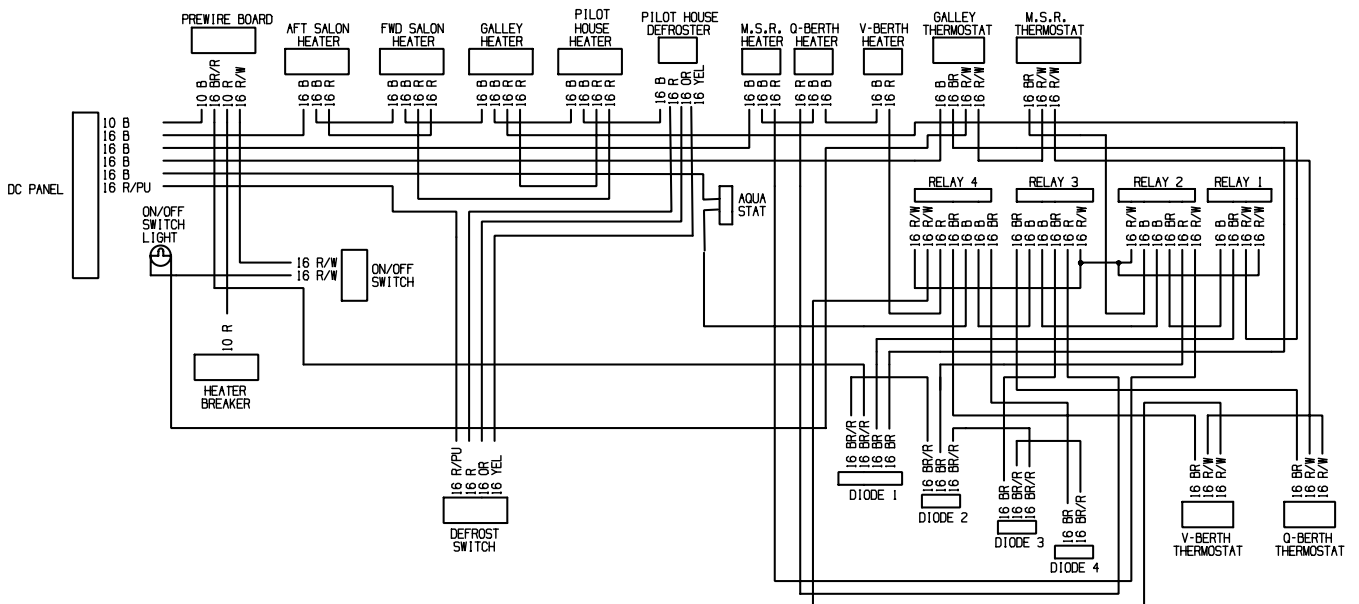

Command Bridge Harness

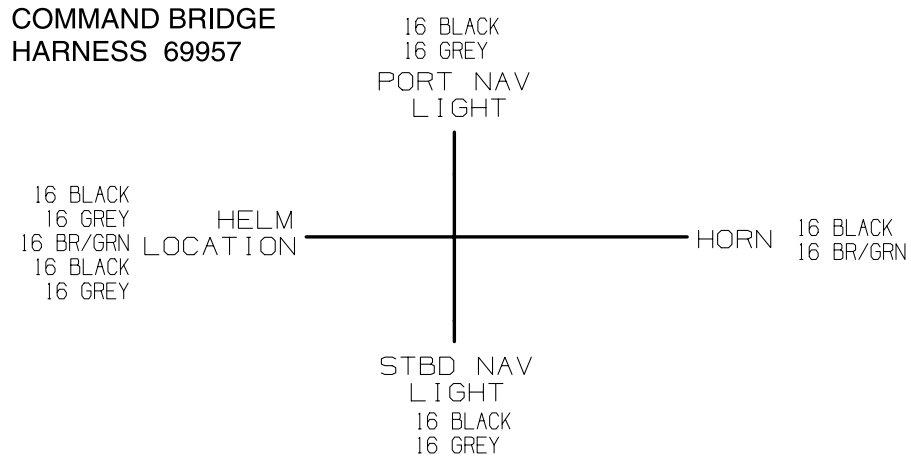

Generator Harness

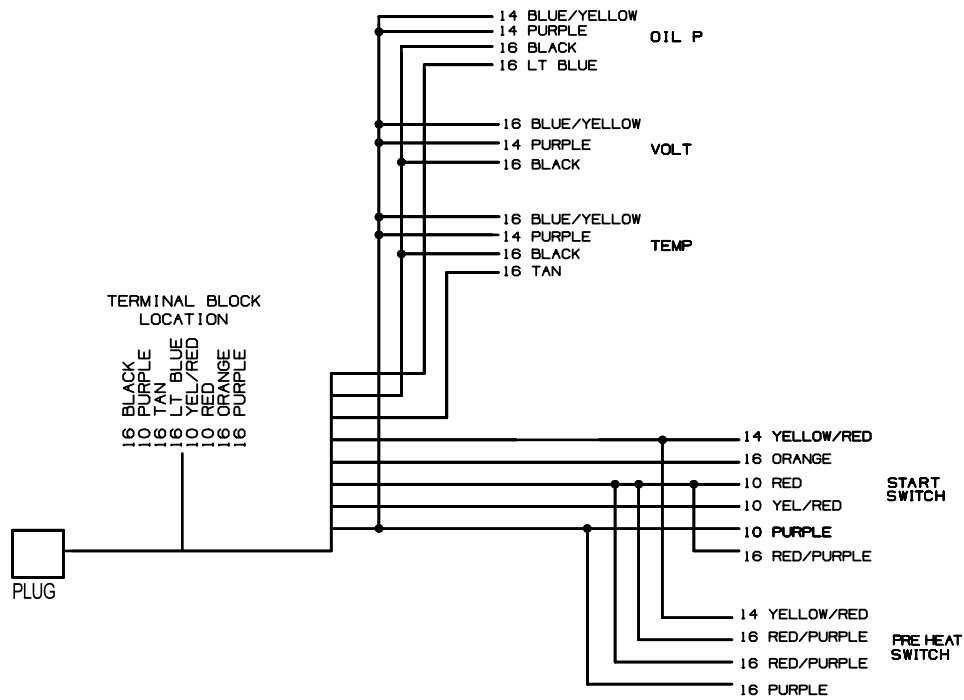

DC Panel

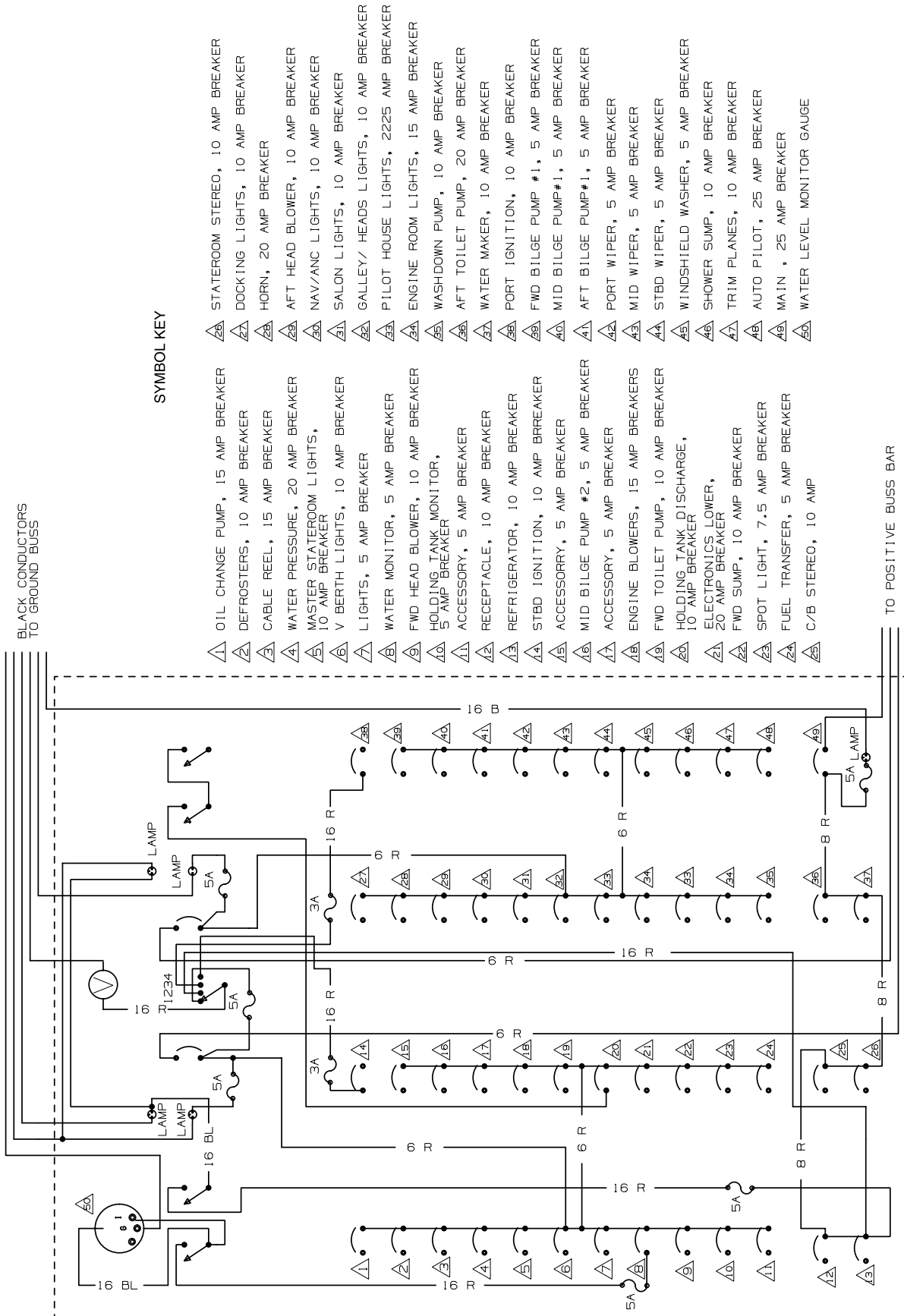

SYMBOL KEY

- 1 OIL CHANGE PUMP, 15 AMP BREAKER
- 2 DEFROSTERS, 10 AMP BREAKER
- 3 CABLE REEL, 15 AMP BREAKER
- 4 WATER PRESSURE, 20 AMP BREAKER
- 5 MASTER STATEROOM LIGHTS, 10 AMP BREAKER
- 6 V BERTH LIGHTS, 10 AMP BREAKER
- 7 LIGHTS, 5 AMP BREAKER
- 8 WATER MONITOR, 5 AMP BREAKER
- 9 FWD HEAD BLOWER, 10 AMP BREAKER
- 10 HOLDING TANK MONITOR, 5 AMP BREAKER
- 11 ACCESSORY, 5 AMP BREAKER
- 12 RECEPTACLE, 10 AMP BREAKER
- 13 REFRIGERATOR, 10 AMP BREAKER
- 14 STBD IGNITION, 10 AMP BREAKER
- 15 ACCESSORY, 5 AMP BREAKER
- 16 MID BILGE PUMP #2, 5 AMP BREAKER
- 17 ACCESSORY, 5 AMP BREAKER
- 18 ENGINE BLOWERS, 15 AMP BREAKERS
- 19 FWD TOILET PUMP, 10 AMP BREAKER
- 20 HOLDING TANK DISCHARGE, 10 AMP BREAKER
- 21 ELECTRONICS LOWER, 20 AMP BREAKER
- 22 FWD SUMP, 10 AMP BREAKER
- 23 SPOT LIGHT, 7.5 AMP BREAKER
- 24 FUEL TRANSFER, 5 AMP BREAKER
- 25 C/B STEREO, 10 AMP BREAKER
- 26 STATEROOM STEREO, 10 AMP BREAKER
- 27 DOCKING LIGHTS, 10 AMP BREAKER
- 28 HORN, 20 AMP BREAKER
- 29 AFT HEAD BLOWER, 10 AMP BREAKER
- 30 NAV/ANC LIGHTS, 10 AMP BREAKER
- 31 SALON LIGHTS, 10 AMP BREAKER
- 32 GALLEY/ HEADS LIGHTS, 10 AMP BREAKER
- 33 PILOT HOUSE LIGHTS, 2225 AMP BREAKER
- 34 ENGINE ROOM LIGHTS, 15 AMP BREAKER
- 35 WASHDOWN PUMP, 10 AMP BREAKER
- 36 AFT TOILET PUMP, 20 AMP BREAKER
- 37 WATER MAKER, 10 AMP BREAKER
- 38 PORT IGNITION, 10 AMP BREAKER
- 39 FWD BILGE PUMP #1, 5 AMP BREAKER
- 40 MID BILGE PUMP#1, 5 AMP BREAKER
- 41 AFT BILGE PUMP#1, 5 AMP BREAKER
- 42 PORT WIPER, 5 AMP BREAKER
- 43 MID WIPER, 5 AMP BREAKER
- 44 STBD WIPER, 5 AMP BREAKER
- 45 WINDSHIELD WASHER, 5 AMP BREAKER
- 46 SHOWER SUMP, 10 AMP BREAKER
- 47 TRIM PLANES, 10 AMP BREAKER
- 48 AUTO PILOT, 25 AMP BREAKER
- 49 MAIN, 25 AMP BREAKER
- 50 WATER LEVEL MONITOR GAUGE

AC Panel

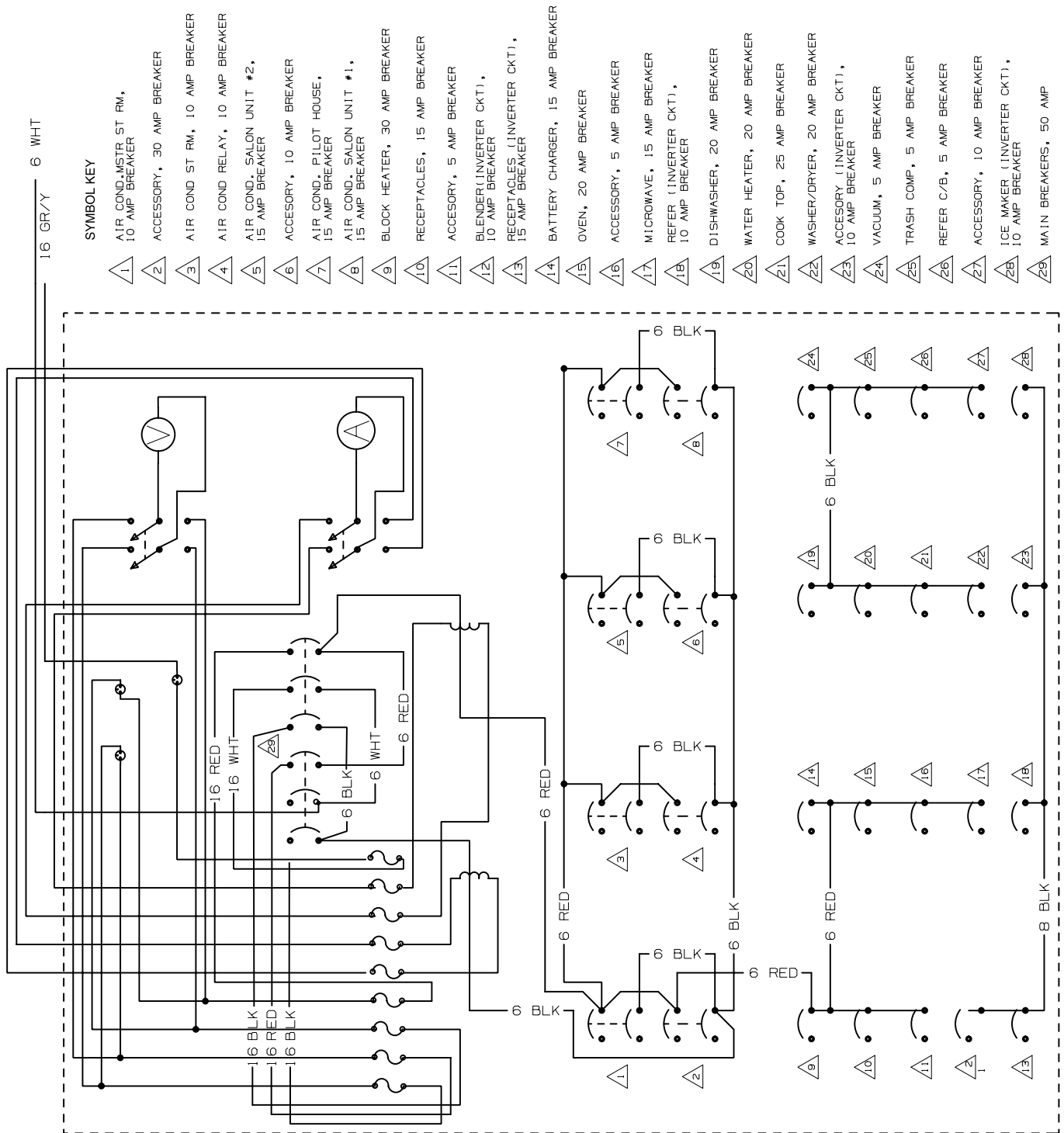

Receptacle Circuits

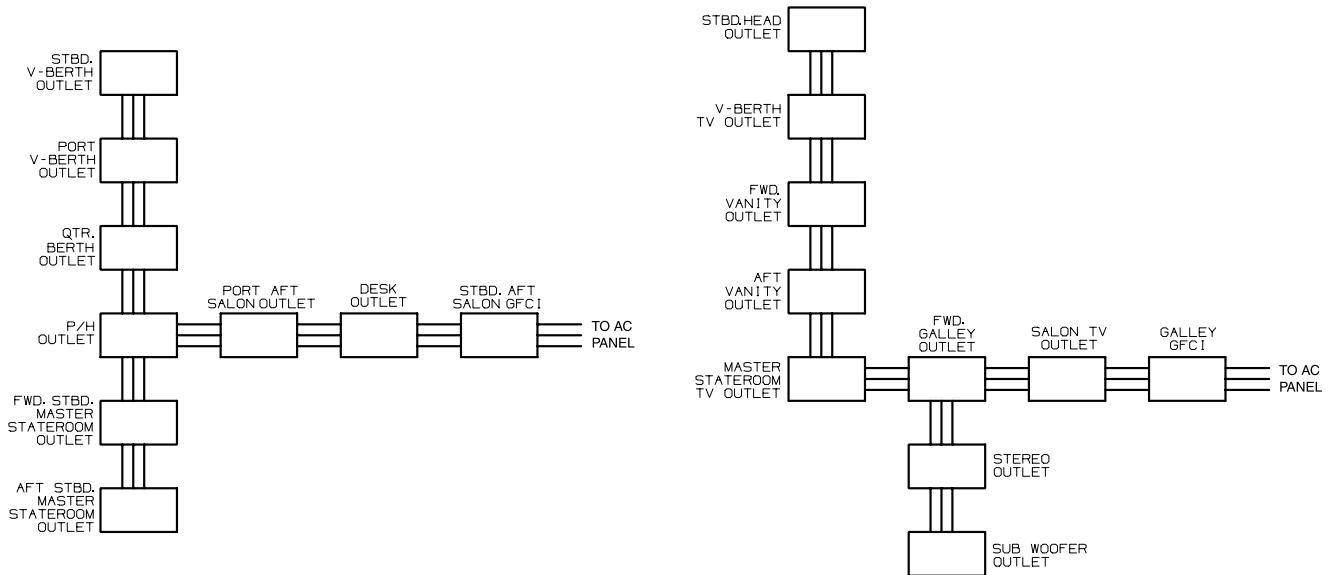

Battery & Charging System

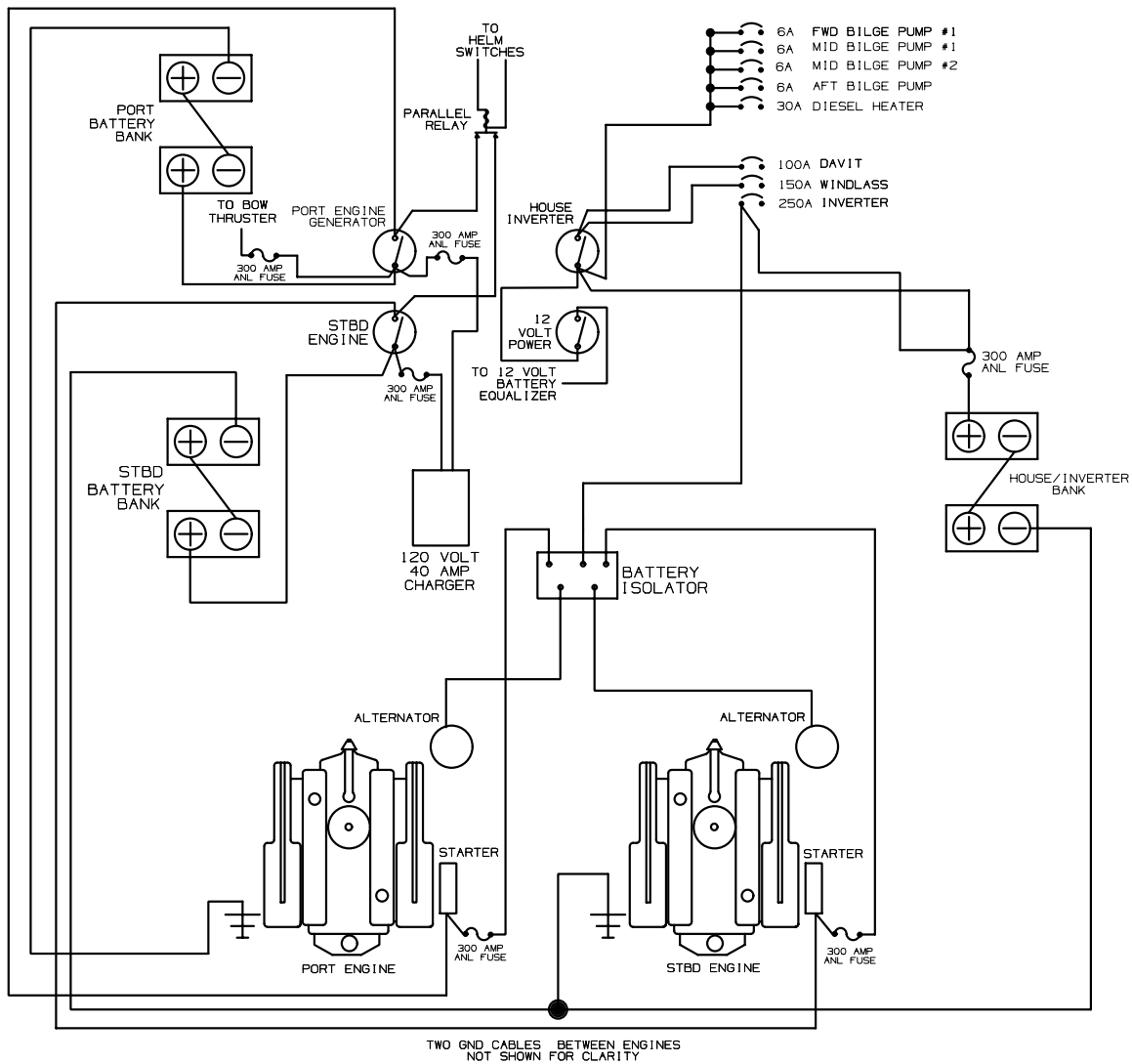

Important Records

Selling Dealer

Name Of Dealership

Address

Phone/FAX/E-mail

Sales Manager

Service Manager

Engines

Manufacturer

Model Name/Number

Port Engine Serial Number

Starboard Engine Serial Number

Oil Type/SAE

Quarts per Engine

Filter Type

Propeller

Manufacturer

Pitch

Model Number

Generator

Manufacturer

Model Name/Number

Serial Number

Oil Type/SAE

Quarts

Filter Type

Fuel System

Fuel Capacity

Filter Type

Plumbing

Fresh Water Tank Capacity

Waste Holding Tank Capacity

Key Numbers

Cabin

Ignition

Other

Other

Electronics

Manufacturer

Model Name/Number

Serial Number

Manufacturer

Model Name/Number

Serial Number

Manufacturer

Model Name/Number

Serial Number

Manufacturer

Model Name/Number

Serial Number

Manufacturer

Model Name/Number

Serial Number

Manufacturer

Model Name/Number

Serial Number

Float Plan

Before going boating, fill out a copy of this float plan (or similar) and leave it with a **reliable** person whom you can depend on to contact the Coast Guard or other rescue organization, if you do not return as scheduled.

Description of Boat

Registration/Documentation Number		
Length	Make	Type
Hull Color		Trim Color
Fuel Capacity	Engine Type	Number of Engines
Distinguishing Features		
Distinguishing Features		

Operator of Boat

Full Name		
Male or Female	Age	Health
Address		
Address		
Phone/FAX/E-mail		
Operator's Experience		

Persons Onboard

Full Name		
Age	Health	Phone Number
Full Name		
Age	Health	Phone Number
Full Name		
Age	Health	Phone Number
Full Name		
Age	Health	Phone Number
Full Name		
Age	Health	Phone Number
Full Name		
Age	Health	Phone Number
Full Name		
Age	Health	Phone Number

Survival Equipment

Number of PFDs	Flares (Yes/No)	Mirror (yes or no)
Smoke Signals (Yes/No)	Flashlight (Yes/No)	Food (Yes/No)
Water (Yes/No)	Anchor (Yes/No)	Raft/Dinghy (Yes/No)
Paddles (Yes/No)	EPIRB (Yes/No)	Other
Other	Other	Other
Marine Radio (Yes/No)	Type	Frequencies

Vehicle Description

Make	Model
Color	License Number
Where is the Vehicle Parked?	

Trip Expectations

Departing From	
Departure Date	Departure Time
Stopover 1	
Arrive No Later Than: Date	Arrive No Later Than: Time
Stopover 2	
Arrive No Later Than: Date	Arrive No Later Than: Time
Stopover 3	
Arrive No Later Than: Date	Arrive No Later Than: Time
Stopover 4	
Arrive No Later Than: Date	Arrive No Later Than: Time
Stopover 5	
Arrive No Later Than: Date	Arrive No Later Than: Time
Stopover 6	
Arrive No Later Than: Date	Arrive No Later Than: Time
Final Destination Port (If Different Than Home Port)	
Arrive No Later Than: Date	Arrive No Later Than: Time

If not returned by the date and time listed above, call the Coast Guard or other local authority.

Coast Guard Phone Number
Local Authority Phone Number

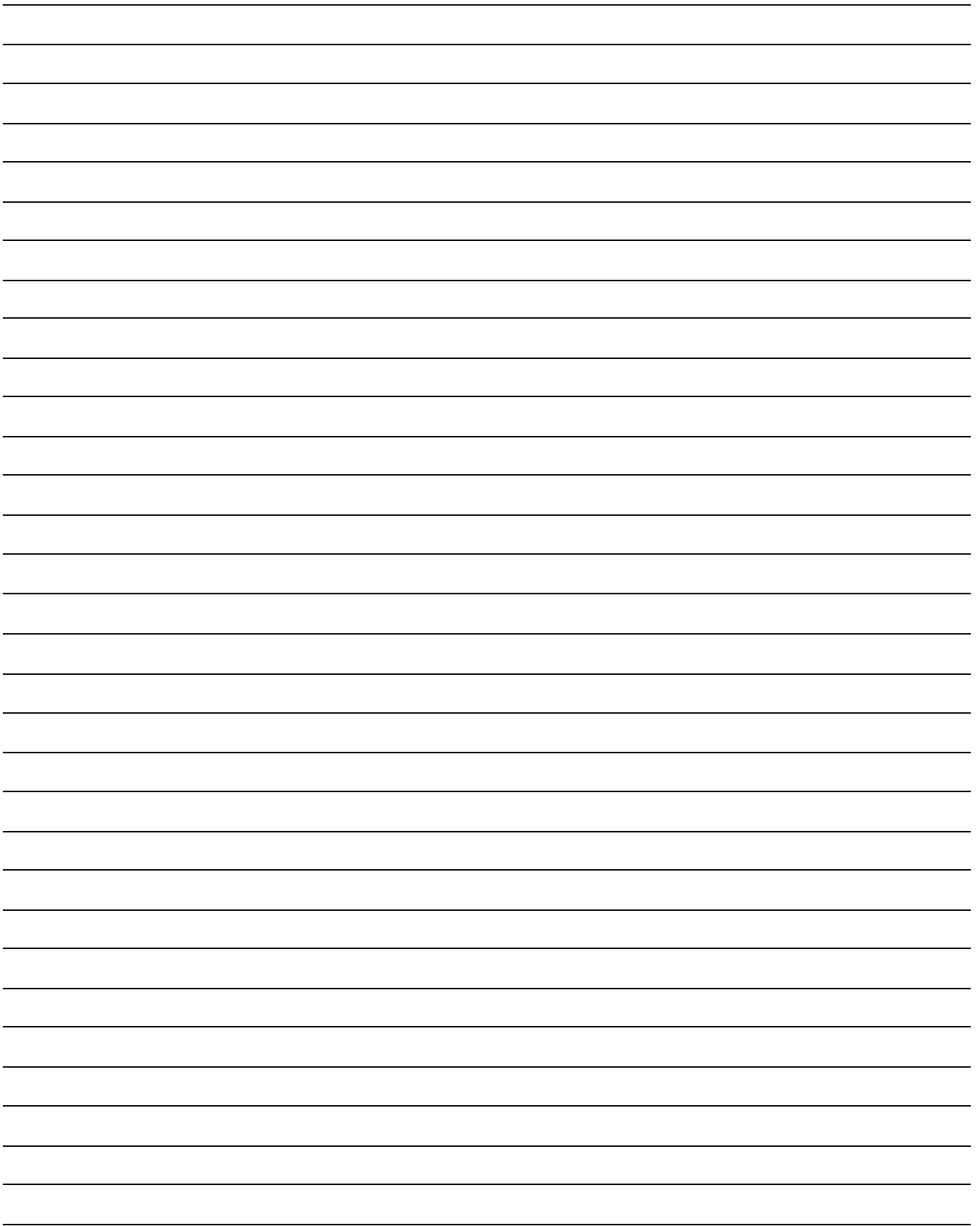

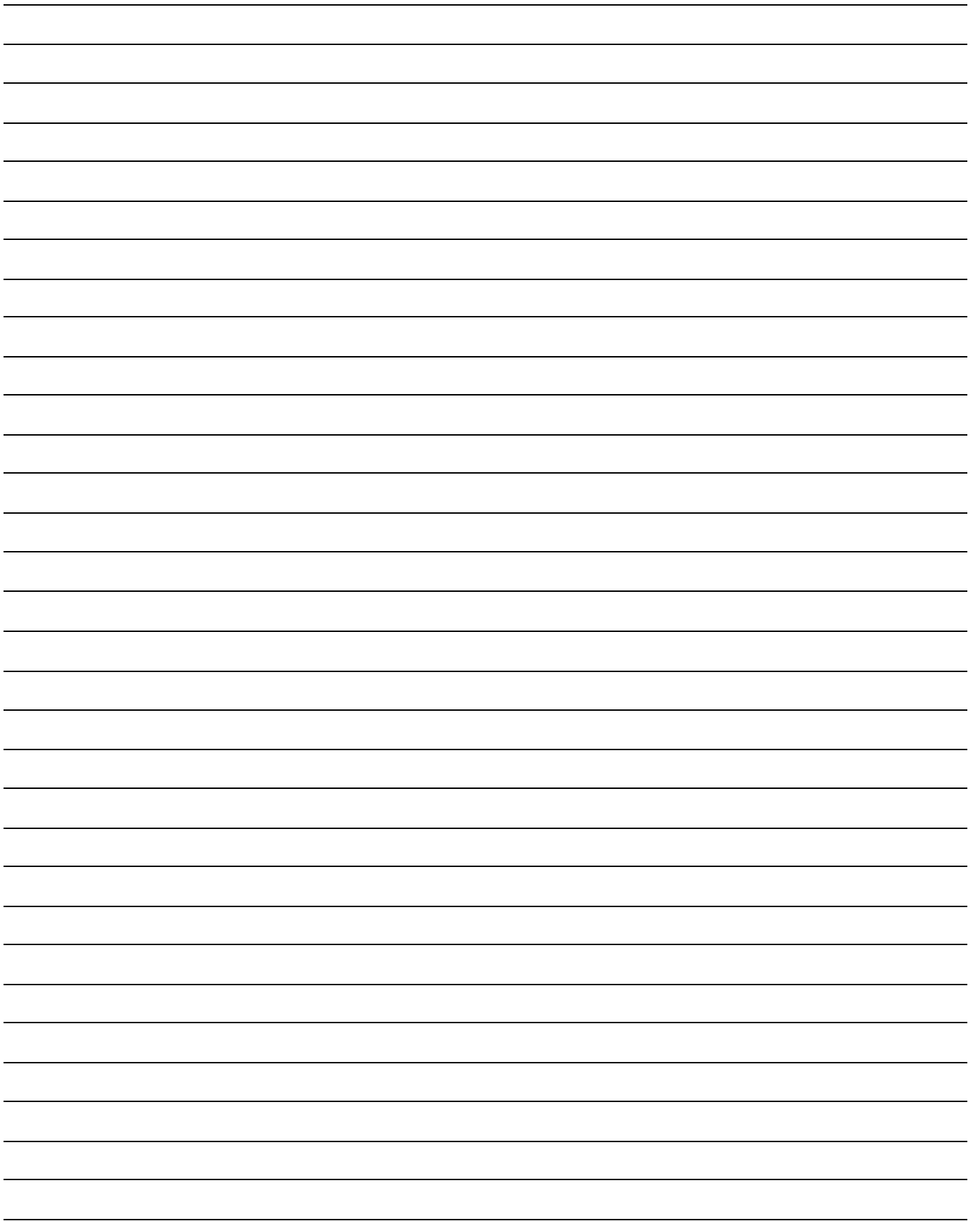

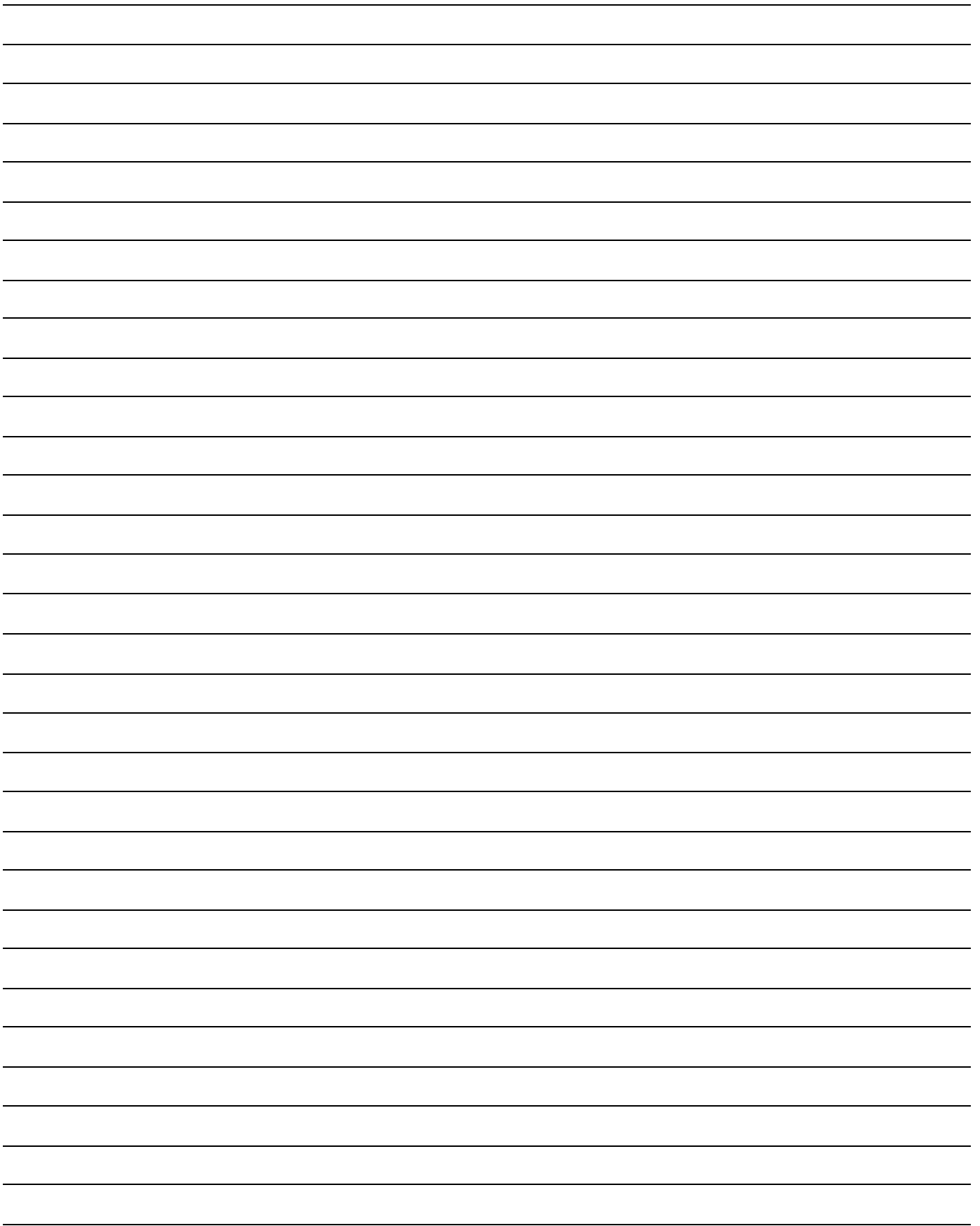

MERIDIAN™
YACHTS

A subsidiary of the Brunswick Boat Group
www.meridian-yachts.com | part # 1755292