



MERIDIANTM
YACHTS

459 MOTORYACHT OWNER'S MANUAL

Date of Purchase _____

Port Engine Serial Number: _____

Starboard Engine Serial Number: _____

Hull Identification Number: _____

Hull Identification Number

- The Hull Identification Number (HIN) is located on the starboard side of the transom.
- Record the HIN (and the engine serial numbers) in the space provided above.
- Please refer to the HIN for any correspondence or orders.

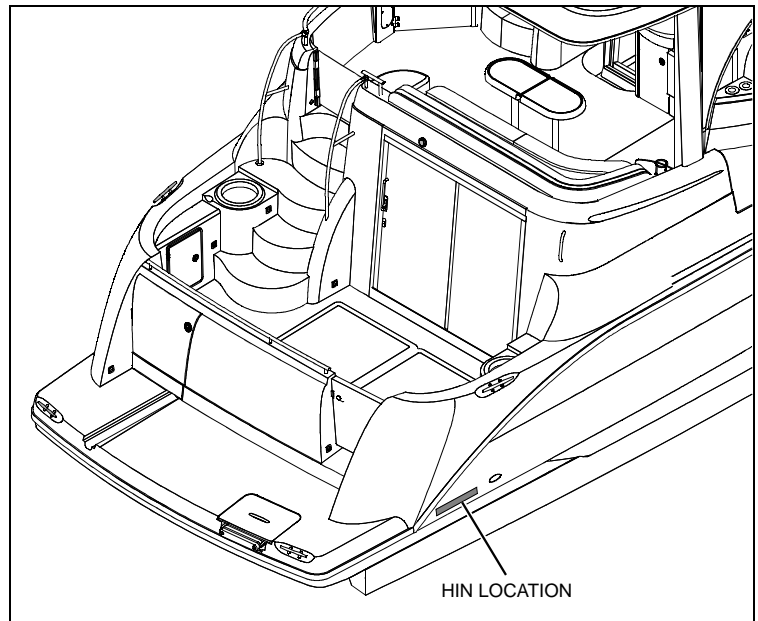

© 2004 Meridian Technical Publications. All rights reserved.

No part of this publication may be reproduced, stored in any retrieval system, or transmitted in any form by any means, electronic, mechanical, photocopying, recording or otherwise, without prior written permission of Meridian.

Printed in the United States of America.

General Notes

The material in this document is for information only and is subject to change without notice. While reasonable efforts have been made in the preparation of this document to assure its accuracy, Meridian assumes no liability resulting from errors or omissions in this document, or from the use of information contained herein.

Due to our commitment to product improvement, Meridian reserves the right to make changes in the product design, specifications, and equipment at any time without notice or obligation. Illustrations and/or photos may show optional equipment.

All Meridian products meet or exceed USCG (United States Coast Guard) and/or NMMA (National Marine Manufacturer's Association) construction standards. Manufactured with 1,1,1 Trichloroethane, a substance which harms public health and environment during the manufacturing process by destroying ozone in the upper atmosphere.

Proprietary Rights

This document discloses subject matter in which Meridian has proprietary rights. The information and design disclosed herein were originated by and are the property of Meridian. Neither receipt nor possession thereof confers or transfers any right to reproduce, copy, alter or disclose the document or any part thereof, any information contained therein, or to construct boats or any item from it, except by written permission from or written agreement with Meridian. This document is to be returned upon request to Meridian.

CONTENTS

1 Chapter 1: Welcome Aboard!

- 1 Dimensions and Tank Capacities
- 1 Layout View
- 1 Dealer Service
- 2 Warranty Information
- 2 Boating Experience
- 2 Qualified Maintenance
- 3 Engines & Accessories Guidelines
 - 3 *Propellers*
- 3 Engines & Accessories Literature
- 4 Safety Standards
- 5 Special Care For Moored Yachts
 - 5 *Sacrificial Anodes (Zincs)*
- 6 Yacht Lifting
- 7 Carbon Monoxide (CO)
 - 7 *Facts about CO*
 - 7 *Factors That Increase the Effects of CO Poisoning*
 - 8 *Where and How CO Can Accumulate*
 - 8 *How to Protect Yourself and Others From CO*
 - 9 *Trip Checklist*
 - 9 *Monthly Checklist*
 - 9 *Annual Checklist*
 - 9 *Carbon Monoxide Alarm System*
 - 10 *More Information*

11 Chapter 2: Locations

- 11 Exterior Views
 - 11 *Hull Views*
 - 12 *Forward Deck View*
 - 12 *Aft Deck Views*
 - 13 *Helm Station(s)*
- 14 Component Locations

32 Chapter 3: Propulsion & Related Systems

- 32 Engines
- 32 Engine Cooling System
- 33 Exhaust System
- 35 Fuel System
 - 37 *Fuel Fills & Vents*
 - 37 *Anti-siphon Valves (Gas Engines Only)*
 - 37 *Electronic Fuel Shut-off Valves (Diesel Engines Only)*
 - 38 *Gas Engine Fuel Filters*
 - 38 *Fuel Filter/Water Separators (Diesel Engines Only)*
 - 38 *Fuel Transfer Pump (Diesel Engines Only) (If Equipped)*
- 39 Fire Suppression System (If Equipped)
- 40 Shaft-Transmission Alignment
 - 40 *Shaft Log Packless Sealing System*

41 Chapter 4: Controls & Gauges

- 41 Steering
 - 41 *Rudder Stuffing Gland*
- 42 Autopilot (If Equipped)
- 42 Shift/Throttle Controls
 - 42 *Engine Synchronization (If Equipped)*
- 43 Trim Tabs
- 44 Dual Thruster System
- 45 Gauges
 - 45 *Cleaning Gauges*
 - 45 *Gauge Fogging*
 - 45 *Radio Transmission Interference*
 - 45 *Twin Engine Readings*
 - 45 *Fuel Gauge*

46 Chapter 5: Navigation & Communication Equipment

- 46 Compass
- 46 Depth Finder
- 46 VHF Radio (If Equipped)
- 47 Radar (If Equipped)
- 47 Global Positioning System (GPS) (If Equipped)

48 Chapter 6: Plumbing

- 48 Bilge Pumps
 - 49 *Bilge Pump Testing*
 - 50 *Autofloat Switches*
- 51 Seawater Systems
 - 51 *Seacocks*
 - 51 *Seawater Strainers*
 - 52 *Seawater Washdown System (If Equipped)*
- 53 Freshwater System
 - 54 *Freshwater System Winterization*
 - 55 *Transom Shower*
 - 55 *City Water Inlet*
 - 56 *Water Heater*
 - 56 *Winterizing the Water Heater*
- 57 Drain Systems
 - 57 *Deck Drains*
 - 57 *Gray Water Drains*
 - 57 *Sump Pump Drain System*
 - 57 *Sump Box Cleaning*
 - 57 *Sump System Winterization*
- 58 Marine Head & Holding Tank
 - 58 *VacuFlush Head System*
 - 59 *Macerator (If Equipped)*

60 Chapter 7: Deck Equipment

- 60 Cleats
- 60 Windlass
- 61 Canvas
 - 62 *Canvas Care*
 - 63 *Clear Vinyl Care*

64 Chapter 8: Appliances & Entertainment Systems

- 64 Refrigerator
- 64 Electric Stove (If Equipped)
- 64 Range/Oven (If Equipped)
- 65 Coffeemaker (If Equipped)
- 65 Audio & Visual Equipment
 - 65 *Dockside Television & Telephone Inlet*

66 Chapter 9: Lights

- 66 Care and Maintenance
- 66 Interior & Exterior Lights
- 66 Navigation Lights
- 66 Spotlight

67 Chapter 10: Heating & Air Conditioning

- 67 Air Conditioning System (If Equipped)
- 69 Heat Exchanger Cabin Heat (If Equipped)
- 69 Electric Heaters (If Equipped)

70 Chapter 11: Electrical System

- 71 12-Volt DC System
 - 71 *Batteries*
 - 71 *Battery Switches*
 - 72 *Emergency Battery Parallel Switch*
 - 73 *Fuses and Circuit Breakers*
 - 73 *12-Volt Accessory Outlet(s)*
 - 73 *Alternators*
 - 74 *Battery Charger or Inverter/Charger*
- 75 110-Volt AC System
 - 76 *Shore Power*
 - 77 *Connecting To Shore Power*
 - 78 *Shore Power Cable Hoist (If Equipped) (50-amp/220-Volt Only)*
 - 78 *Parallel Switch (If Equipped With Dual Shore Power)*
 - 78 *Inverter Power (If Equipped)*
 - 79 *Generator*
 - 81 *Starting Generator*
- 82 Electrical Routings
 - 82 *12-Volt DC Deck Electrical Harness*
 - 83 *12-Volt DC Hull Electrical System*
 - 84 *Power Inverter (If Equipped)*
 - 85 *Battery System*
 - 86 *Bonding Harness*
 - 87 *110-Volt AC Electrical Harness*
- 88 Wiring Diagrams
 - 88 *Engine Electrical System*
 - 89 *12-Volt DC Command Bridge Electrical System*
 - 90 *12-Volt DC Cabin Electrical System*
 - 91 *12-Volt DC Auxiliary Electrical System*
 - 92 *110/220-Volt AC Electrical System*
 - 93 *110/220-Volt AC Electrical System (If Equipped)*

94 Important Records

95 Float Plan

Hazard Boxes & Symbols

The hazard boxes and symbols shown below are used throughout this manual to call attention to potentially dangerous situations which could lead to either personal injury or product damage. **Read ALL warnings carefully and follow ALL safety instructions.**

 **DANGER!**
This box alerts you to immediate hazards which *WILL* cause severe personal injury or death if the warning is ignored.

 **WARNING!**
This box alerts you to hazards or unsafe practices which *COULD* result in severe personal injury or death if the warning is ignored.

 **CAUTION**
This box alerts you to hazards or unsafe practices which *COULD* result in minor personal injury or cause product or property damage if the warning is ignored.

NOTICE
This box calls attention to installation, operation or maintenance information, which is important to proper operation but is *not* hazard related.

 FIRE HAZARD!	 EXPLOSION HAZARD!	 NO OPEN FLAME!	 ELECTRICAL HAZARD!	 HOT HAZARD!
---	--	---	--	--

 FALLING HAZARD!	 ROTATING PROPELLER HAZARD!	 RUN BILGE BLOWERS FOR 4 MINUTES!
--	---	--

DANGER
CARBON MONOXIDE
CO POISONING HAZARD!

Chapter 1: Welcome Aboard!

- This *Owner's Manual* provides information about your yacht that is **not** covered in the *Cruiser & Yacht Owner's Manual Supplement*.
- **Before** using your yacht, study this *Owner's Manual*, the *Cruiser & Yacht Owner's Manual Supplement*, and **all** engine and accessory literature carefully.
- Keep this *Owner's Manual* and the *Cruiser & Yacht Owner's Manual Supplement* on your yacht in a secure, yet readily available place.

Dimensions and Tank Capacities

Overall Length	Bridge Clearance	Beam	Draft (Hull)	Draft (Maximum)	Fuel Capacity	Freshwater Capacity	Waste Holding Tank Capacity
47' 10"	16' 9"	14' 4"	2' 8"	3' 10"	330 Gallons	90 Gallons	55 Gallons

Layout View

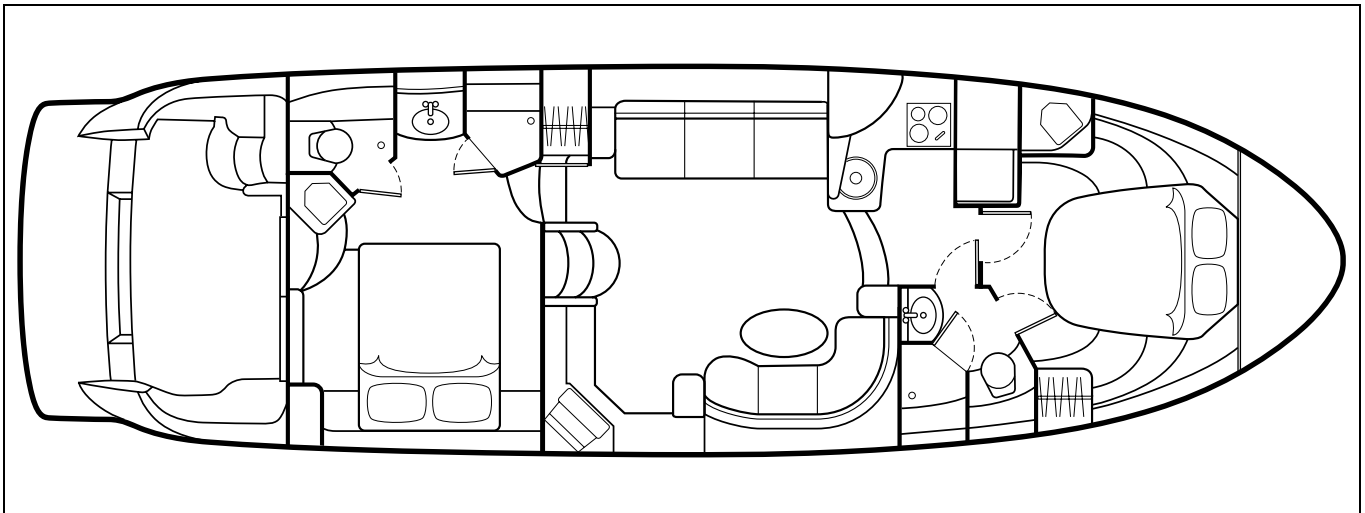

Dealer Service

- Your dealer is your key to service.
- Ask your dealer to explain **all** systems **before** taking delivery of your yacht.
- Contact your dealer if you have any questions or problems with your new yacht.
- If your dealer cannot help, call our customer service hotline: 360-403-2198 or send us a FAX: 360-403-1158.
- Buy replacement parts from any authorized Meridian dealer.

Warranty Information

- Meridian offers a Limited Warranty on each new Meridian purchased through an authorized Meridian dealer.
- A copy of the Limited Warranty was included in your owner's packet.
- If you did not receive a copy of the Limited Warranty, please contact your Meridian dealer or call 360-403-2198 for a copy.

Boating Experience

WARNING!

CONTROL HAZARD!

A qualified operator *must* be in control of the yacht at *all* times. Do *NOT* operate your yacht while under the influence of alcohol or drugs.

If this is your first yacht or if you are changing to a type of yacht you are *not* familiar with, for your own comfort and safety, obtain handling and operating experience *before* assuming command of this yacht.

Take one of the boating safety classes offered by the U.S. Power Squadrons or the U.S. Coast Guard Auxiliary. For more course information, including dates and locations of upcoming classes, contact the organizations directly:

- U.S. Power Squadrons: 1-888-FOR-USPS (1-888-367-8777) or on the Internet at: <http://www.usps.org>
- In Canada, for the CPS courses call 1-888-CPS-BOAT.
- U.S. Coast Guard Auxiliary: 1-800-368-5647 or on the Internet at: <http://www.cgaux.org>

Outside the United States, your Meridian dealer, national sailing federation or local boat club can advise you of local sea schools or competent instructors.

Qualified Maintenance

WARNING!

To maintain the integrity and safety of your yacht, allow *only* qualified personnel to perform maintenance on, or in any way modify the:

- **Steering System**
- **Propulsion System**
- **Engine Control System**
- **Fuel System**
- **Environmental Control System**
- **Electrical System**
- **Navigational System.**

- Failure to maintain your yacht's systems (listed in the warning above) as designed could violate the laws in your jurisdiction and could expose you and other people to the danger of bodily injury or accidental death.
- Follow the instructions provided in the *Cruiser & Yacht Owner's Manual Supplement*, this *Owner's Manual*, the engine owner's manual and *all* accessory literature.

Engines & Accessories Guidelines

NOTICE

When storing your yacht please refer to your engine's operation and maintenance manuals.

- Your yacht's engines and accessories were selected to provide optimum performance and service.
- Installing different engines or other accessories may cause unwanted handling characteristics.
- Should you choose to install different engines or to add accessories that will affect the yacht's running trim, have an experienced marine technician perform a safety inspection and handling test *before* operating your yacht again.

Certain modifications to your yacht will result in cancellation of your warranty protection.

- *Always* check with your dealer *before* making any modifications to your yacht.

Propellers



CAUTION

ENGINE DAMAGE HAZARD!

The factory standard propellers may not be the best for your particular yacht and load conditions. Refer to the engine manual for engine RPM ratings. The engines should reach, but *NOT* exceed the full rated RPM when full-throttle is applied.

Immediately contact your local Meridian dealer if:

- **The engines cannot reach the full rated RPM when full-throttle is applied, or;**
- **The engines exceed the full rated RPM when full-throttle is applied.**

- Keep the propellers in good repair and at the correct pitch for your particular situation.
- A slightly bent or nicked propeller will adversely affect the performance of your yacht.

Engines & Accessories Literature

- The engines and accessories installed on your yacht come with their own operation and maintenance manuals.
- Read these manuals *before* using the engines and accessories.
- Unless noted otherwise, *all* engine and accessory literature referred to in this *Owner's Manual* is included in your owner's packet.

Safety Standards

⚠ DANGER!



FALLING and ROTATING PROPELLER HAZARD!

- ***NEVER*** allow anyone to ride on parts of the yacht ***NOT*** designed for such use.
- ***Sitting on seat backs, lounging on the forward deck, bow riding, gunwale riding or occupying the transom platform while underway is especially hazardous and will cause personal injury or death.***

⚠ DANGER!





ROTATING PROPELLER and CARBON MONOXIDE POISONING HAZARD!

- ***NEVER*** allow anyone to occupy, or hang from, the back deck or swim platform while the engines are running.
- ***Teak surfing, dragging, or water skiing within 20 feet of a moving watercraft can be fatal.***

⚠ DANGER!

PERSONAL SAFETY HAZARD!

ALWAYS secure the anchor and other loose objects *before* getting underway. The anchor and other items that are ***NOT*** properly secured can come loose when the yacht is moving and cause personal injury or death.

- Your yacht's mechanical and electrical systems were designed to meet safety standards in effect at the time it was built.
- Some of these standards were mandated by law, all of them were designed to insure your safety, and the safety of other people, vessels and property.

In addition to this *Owner's Manual*, please read the *Cruiser & Yacht Owner's Manual Supplement* and ***all*** accessory instructions for important safety standards and hazard information.

Special Care For Moored Yachts

NOTICE

- To help seal the hull bottom and reduce the possibility of gelcoat blistering on moored boats, apply an epoxy barrier coating. The barrier coating should be covered with several coats of anti-fouling paint.
- Many states regulate the chemical content of bottom paints in order to meet environmental standards. Check with your local dealer about recommended bottom paints, and about the laws in effect in your area.

- Whether moored in saltwater or freshwater, your yacht will collect marine growth on its hull bottom.
- This will detract from the yacht's beauty, greatly affect its performance and may damage the gelcoat.
- There are two methods of slowing marine growth:
 1. Periodically haul the yacht out of the water and scrub the hull bottom with a bristle brush and a solution of soap and water.
 2. Occasionally re-paint the hull below the waterline with a good grade of anti-fouling paint.

Sacrificial Anodes (Zincs)

NOTICE

- Do **NOT** paint between the zinc and the metal surface it contacts and do **NOT** paint over the zincs.
- If the zincs are **NOT** bonded correctly, they will **NOT** provide protection.

Your yacht features sacrificial anodes (zincs) to protect underwater metal parts from excessive deterioration. Check the zincs regularly and replace them if they have deteriorated more than 70%.

There are many factors that affect the rate at which the zincs deteriorate, including:

- Water temperature
- Salinity
- Water pollution
- Stray electrical current from the yacht or dock may cause complete deterioration in just a few weeks. If there is rapid zinc deterioration, measure the electrolytic corrosion around your yacht with a corrosion test meter.



NEW SACRIFICIAL ANODE

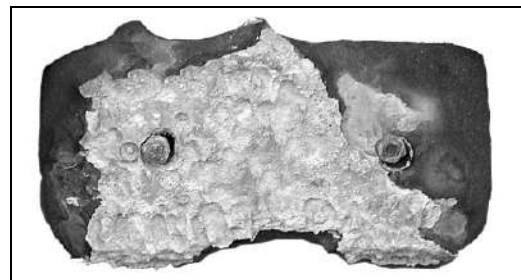

DETERIORATED SACRIFICIAL ANODE

Yacht Lifting

⚠ WARNING!

PERSONAL INJURY and /or PRODUCT OR PROPERTY DAMAGE HAZARD!

- Lifting slings may slip on the hull.
- Avoid serious injury or death by securing the lifting slings together *before* lifting.

⚠ WARNING!

PERSONAL INJURY and /or PRODUCT OR PROPERTY DAMAGE HAZARD!

NEVER lift the yacht using the cleats, or the bow and stern eyes.

⚠ WARNING!

PERSONAL INJURY and /or PRODUCT OR PROPERTY DAMAGE HAZARD!

- Water in the bilge can shift and change the balance of the load.
- If water is present in the bilge, pump or drain the water out of the bilge areas *before* lifting your yacht.

⚠ CAUTION

PRODUCT or PROPERTY DAMAGE HAZARD!

- When lifting any boat, *always* use a spreader bar.
- The spreader bar *must* be equal to the width of the boat at each lifting point.

- *Always* follow the lift equipment's instructions and requirements.
- When lifting your yacht, *always* position the lifting slings at the port and starboard lifting sling label positions, as shown in the illustration.

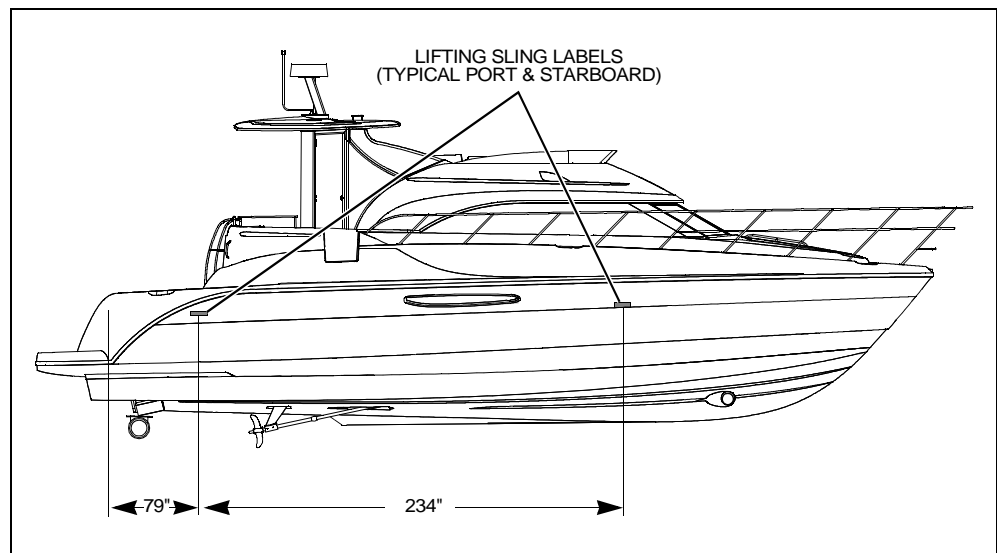

Carbon Monoxide (CO)

⚠ DANGER!	
	<ul style="list-style-type: none"> • Carbon monoxide gas (CO) is colorless, odorless, tasteless, and extremely dangerous. • <i>All</i> engines, generators, and fuel burning appliances produce CO as exhaust. • Prolonged exposure to low concentrations or very quick exposure to high concentrations <i>will</i> cause BRAIN DAMAGE or DEATH. • Teak surfing, dragging, or water skiing within 20 feet of a moving watercraft can be fatal.

Facts about CO

- CO poisoning causes a significant number of boating deaths each year.
- Called the "silent killer", CO is an extremely toxic, colorless, odorless and tasteless gas.
- CO can harm or even kill you inside or outside your yacht.
- CO can affect you whether you're underway, moored, or anchored.
- CO symptoms are similar to seasickness or alcohol intoxication.
- CO can make you sick in seconds. In high enough concentrations, even a few breaths can be fatal.
- Breathing CO blocks the ability of your blood to carry oxygen.
- The effects are cumulative, even low levels of exposure can result in injury or death.

Factors That Increase the Effects of CO Poisoning

- Age
- Smokers or people exposed to high concentrations of cigarette smoke
- Consumption of alcohol
- Lung disorders
- Heart problems
- Pregnancy

Where and How CO Can Accumulate

Stationary Conditions That Increase CO Accumulations Include:

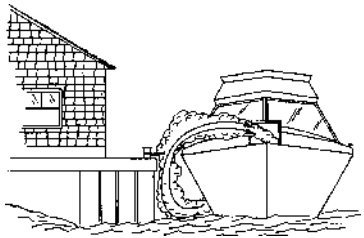
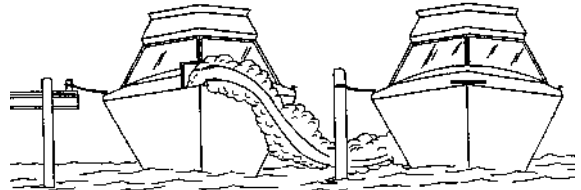
<p>a. Using engine, generator, or other fuel burning device when yacht is moored in a confined space.</p> 	 <p>b. Mooring too close to another boat that is using its engine, generator, or other fuel burning device.</p>
--	--

To correct stationary situations A and/or B:

- **Close all** windows, portlights and hatches.
- If possible, move your yacht away from source of CO.

Running Conditions That Increase CO Accumulations Include:

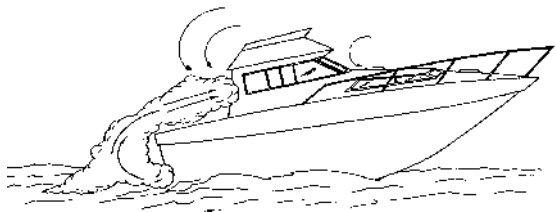
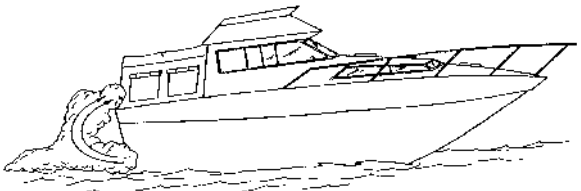
 <p>c. Running yacht with trim angle of bow too high.</p>	 <p>d. Running yacht without through ventilation (station wagon effect).</p>
---	---

To correct running situations C and/or D:

- Trim bow down.
- **Open** windows and canvas.
- When possible, run yacht so that prevailing winds help dissipate exhaust.

How to Protect Yourself and Others From CO

- Know where and how CO may accumulate in and around your yacht (see above).
- Maintain fresh air circulation throughout the yacht at **all** times.
- Know where your engine and generator exhaust outlets are located and keep everyone away from these areas.
- **Never** sit on, or hang onto, the back deck or swim platform while the engines are running.
- **Never** enter the areas under swim platforms where exhaust outlets are located.
- Although CO can be present without the smell of exhaust fumes, if exhaust fumes are detected on the yacht, take **immediate** action to dissipate these fumes.
- Treat symptoms of seasickness as possible CO poisoning. Get the person into fresh air **immediately**. Seek medical attention—unless you're sure it's not CO.
- Install and maintain CO alarms inside your yacht. Do **not** ignore any alarm. Replace alarms as recommended by the alarm manufacturer.
- Follow the checklists provided on the next page.
- Get a Vessel Safety Check.

For information on how to get a free VESSEL SAFETY CHECK, visit www.vesselsafetycheck.org or contact your local U.S. Coast Guard Auxiliary or United States Power Squadrons®.

- U.S. Coast Guard Auxiliary: 1-800-368-5647 or on the Internet at: <http://www.cgaux.org>
- U.S. Power Squadrons: 1-888-FOR-USPS (1-888-367-8777) or on the Internet at: <http://www.usps.org>

Trip Checklist

- Educate *all* passengers about the symptoms of CO poisoning and where CO may accumulate.
- When docked, or rafted with another boat, be aware of exhaust emissions from the other boats.
- Make sure you know where the exhaust outlets are located on your yacht.
- Confirm that water flows from the exhaust outlets when the engines and generator are started.
- Listen for any change in exhaust sound, which could indicate an exhaust component failure.
- Test the operation of each CO alarm by pressing the test button.

Monthly Checklist

- Make sure *all* exhaust clamps are in place and secure.
- Look for exhaust leaking from exhaust system components. Signs include rust and/or black streaking, water leaks, or corroded or cracked fittings.
- Inspect rubber exhaust hoses for burned, cracked, or deteriorated sections. *All* rubber hoses should be pliable and free of kinks.

Annual Checklist

Have a Qualified Marine Technician:

- Replace exhaust hoses if cracking, charring, or deterioration is found.
- Ensure that your engines and generators are properly tuned, and well maintained.
- Inspect each water pump impeller and the water pump housing. Replace if worn. Make sure cooling systems are in working condition.
- Inspect *all* metallic exhaust components for cracking, rusting, leaking, or loosening. Make sure they check the cylinder head gasket, exhaust manifold, water injection elbow, and the threaded adapter nipple between the manifold and the elbow.
- Clean, inspect, and confirm proper operation of the generator cooling water anti-siphon valve (if equipped).

Carbon Monoxide Alarm System

 **DANGER!**



CARBON MONOXIDE POISONING HAZARD!

- The house battery switch must be in the *On* position for the CO Monitors to work.
- If your yacht will be unattended for an extended period of time, turn *Off* the house battery switch or the CO Monitors *will* drain the house battery.
- *Immediately* turn the house battery switch back *On* when you reboard your yacht.

- **NEVER** disconnect the alarm system.
- Read and understand the manufacturer's instructions for your CO alarm system. If you did not receive an instruction manual, call (800) 383-0269 and one will be mailed to you.

More Information

For more information about how you can prevent carbon monoxide poisoning on recreational boats and other ways to boat more safely, contact:

United States Coast Guard
Office of Boating Safety (G-OPB-3)
2100 Second Street SW
Washington, DC 20593
www.uscgboating.org
1-800-368-5647

National Marine Manufacturers
Association (NMMA)
200 East Randolph Drive
Suite 5100
Chicago, IL 60601-9301
www.nmma.org
312-946-6200

American Boat & Yacht Council, Inc.
(ABYC)
3069 Solomon's Island Road
Edgewater, MD 21037-1416
www.abycinc.org
410-956-1050

For information on how to get a free VESSEL SAFETY CHECK, visit www.vesselsafetycheck.org or contact your local U.S. Coast Guard Auxiliary or United States Power Squadrons®.

- U.S. Coast Guard Auxiliary: 1-800-368-5647 or on the Internet at: <http://www.cgaux.org>
- U.S. Power Squadrons: 1-888-FOR-USPS (1-888-367-8777) or on the Internet at: <http://www.usps.org>

Chapter 2: Locations

Exterior Views

Hull Views

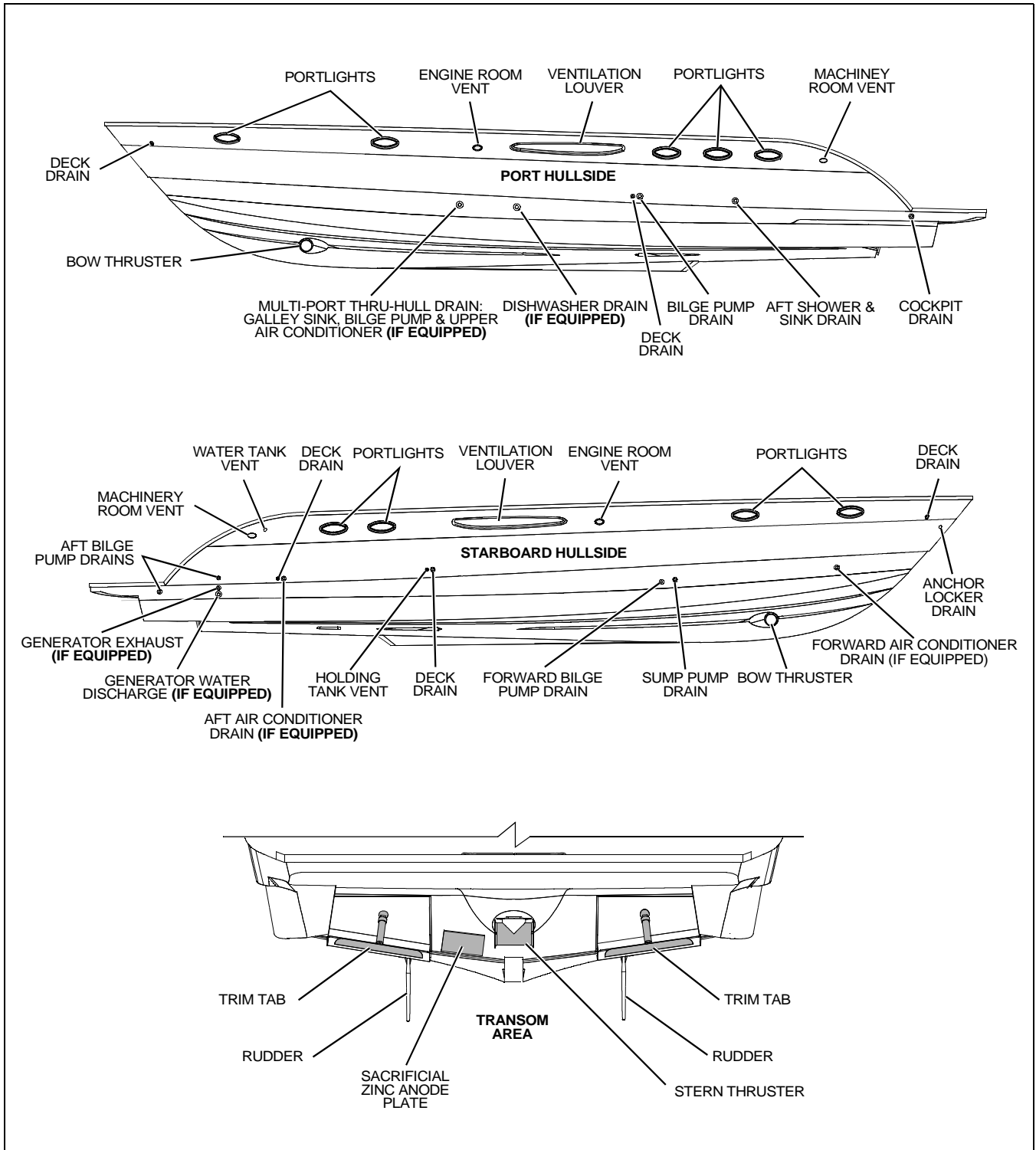

Forward Deck View

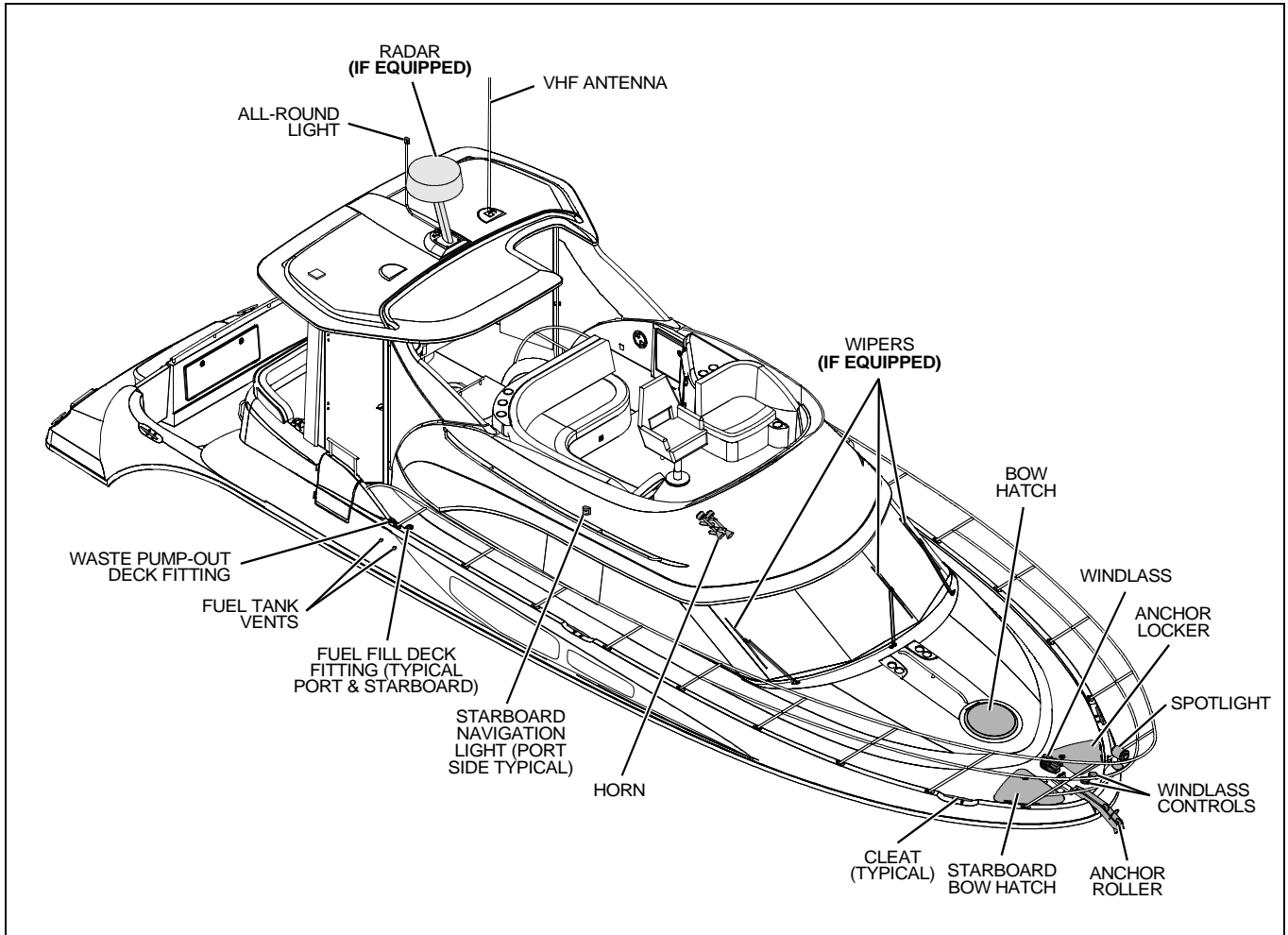

Aft Deck Views

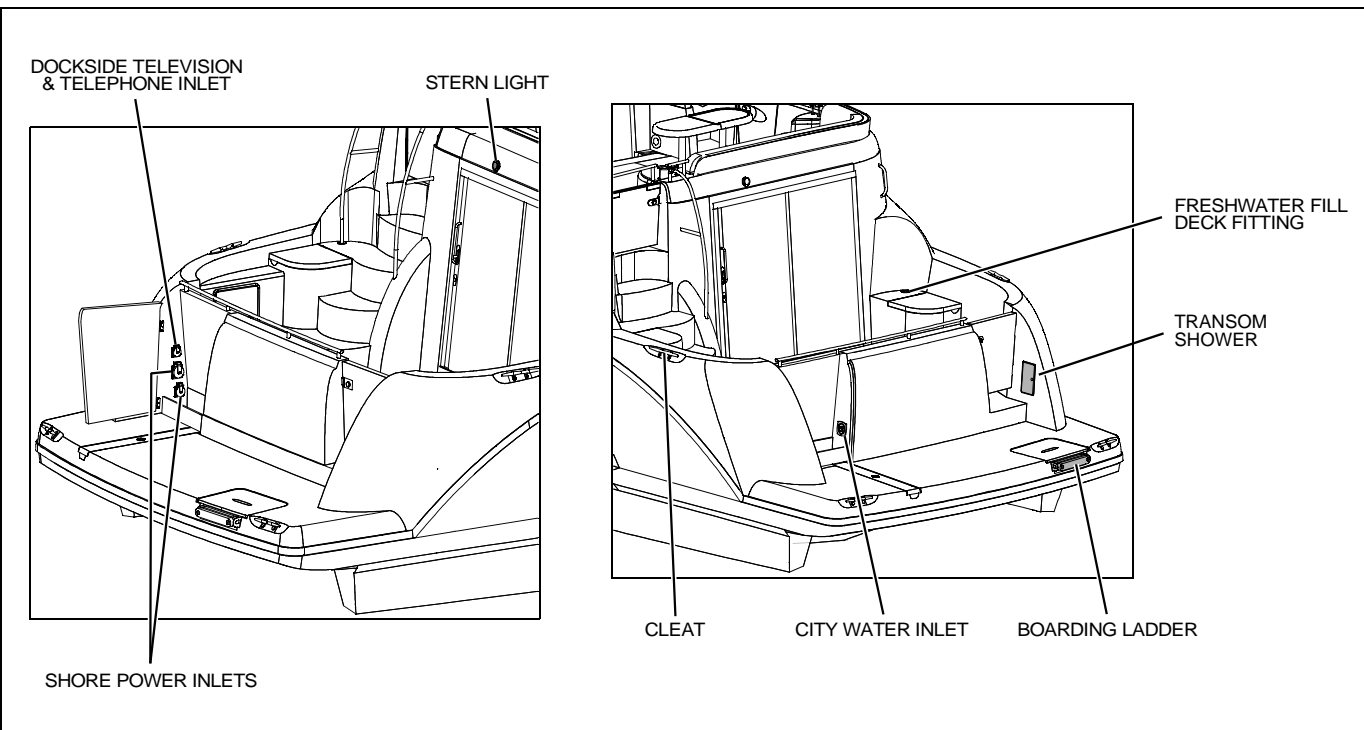

Helm Station(s)

NOTE: TYPICAL HELM LAYOUTS SHOWN. ACTUAL LAYOUTS MAY VARY DEPENDING ON ENGINE & ACCESSORY OPTIONS

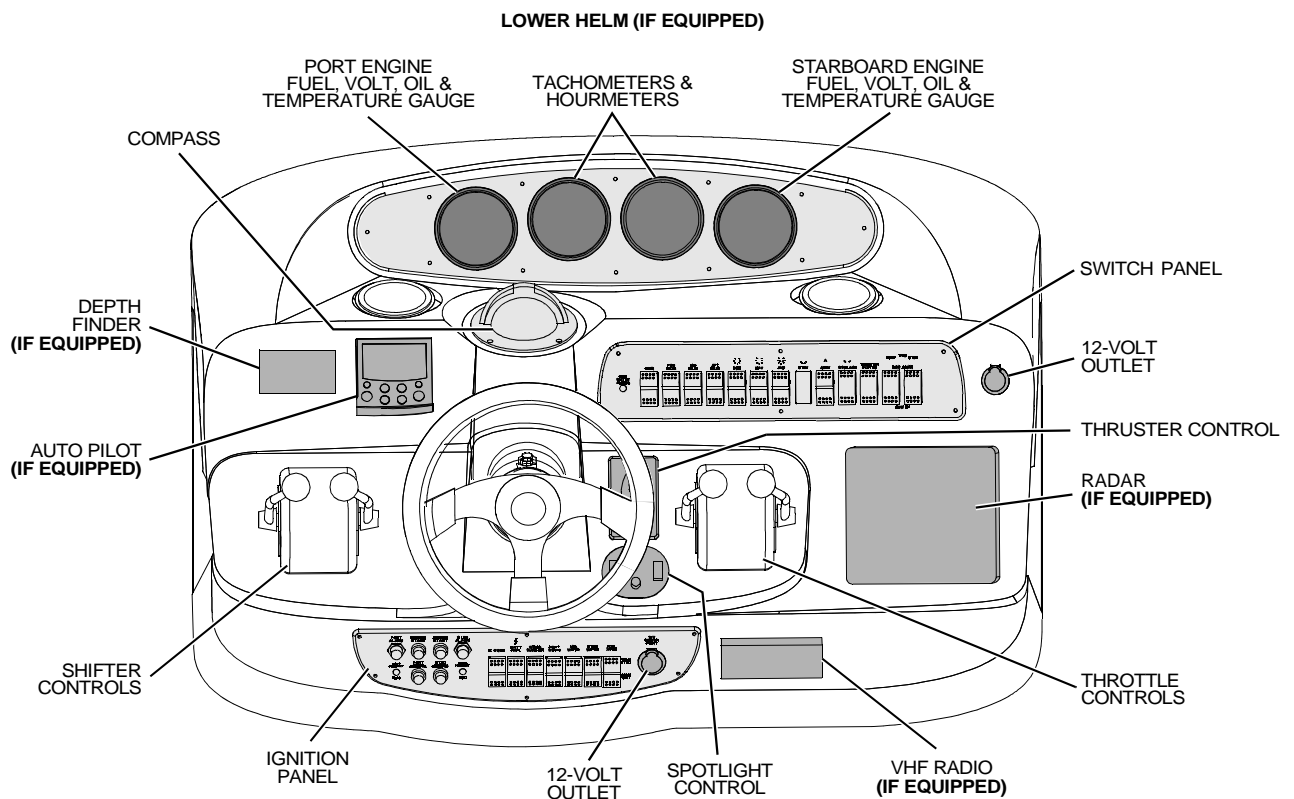
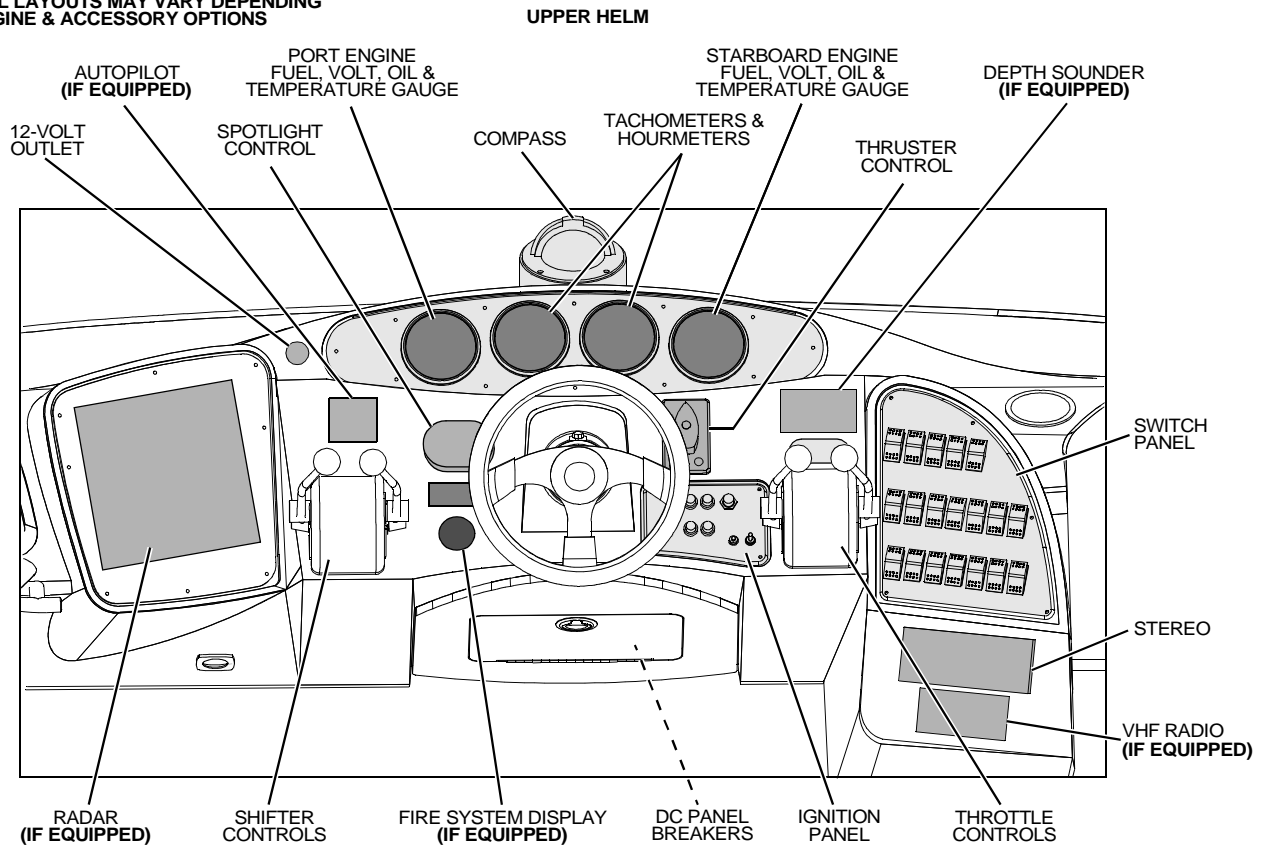

Component Locations

12-Volt Accessory Outlet - Upper Helm:

- Located just to the left of the gauge panel.

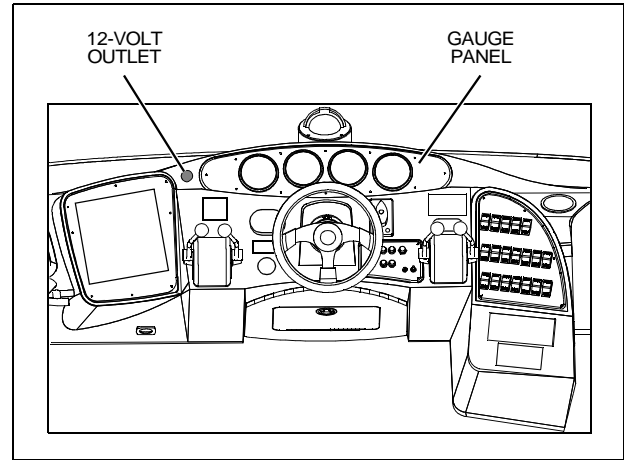

12-Volt Accessory Outlets - Lower Helm (If Equipped):

- One is located just to the right of the switch panel and one is located on the ignition panel.

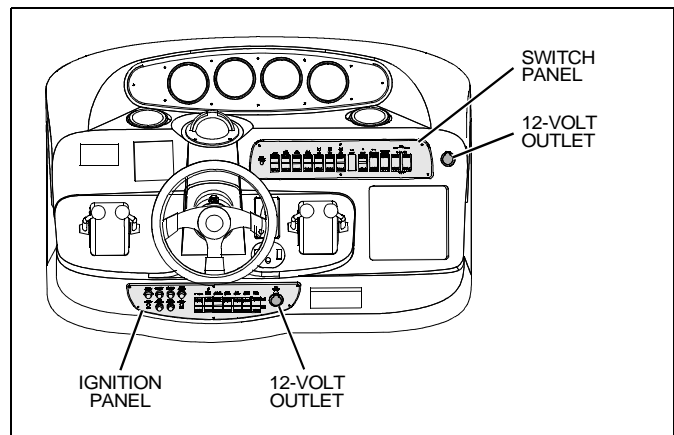

12-Volt Accessory Outlet - Aft Cabin:

- Located on the forward wall.

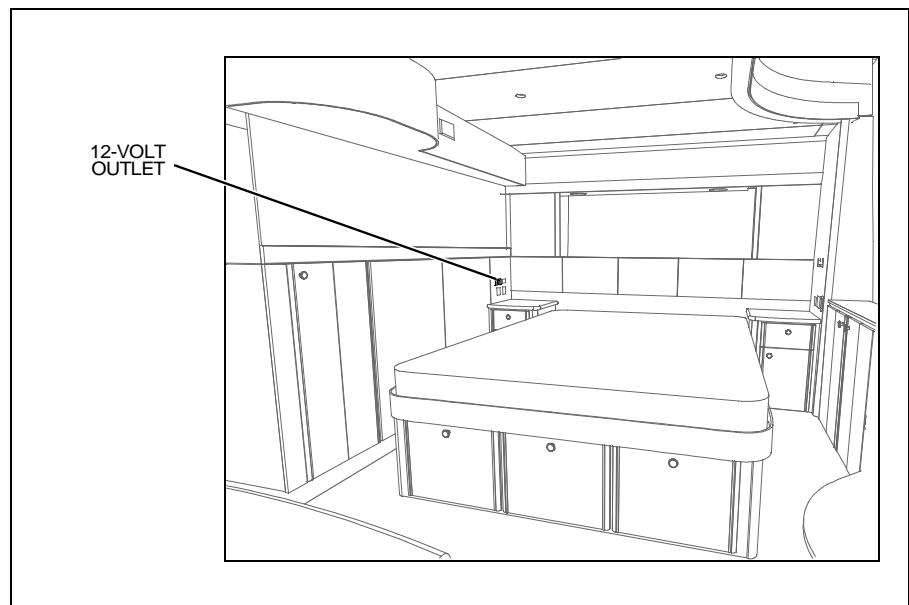

AC & DC Main Distribution Panels

- Located in the upper salon cabinet next to the entry steps.

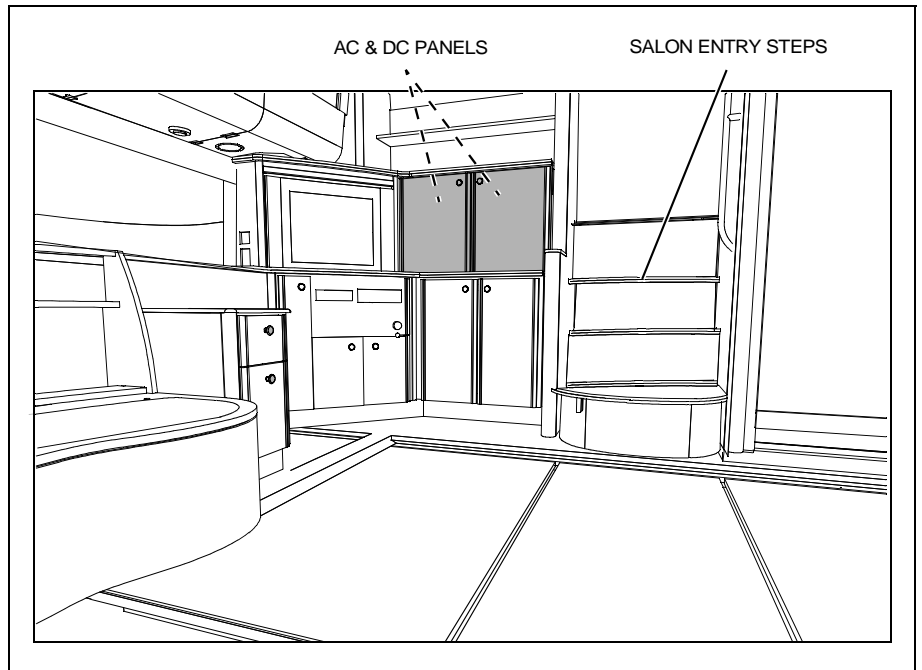

Air Conditioner Seawater Intake Seacock (If Equipped):

- Located in the engine room, forward of the engine room ladder.

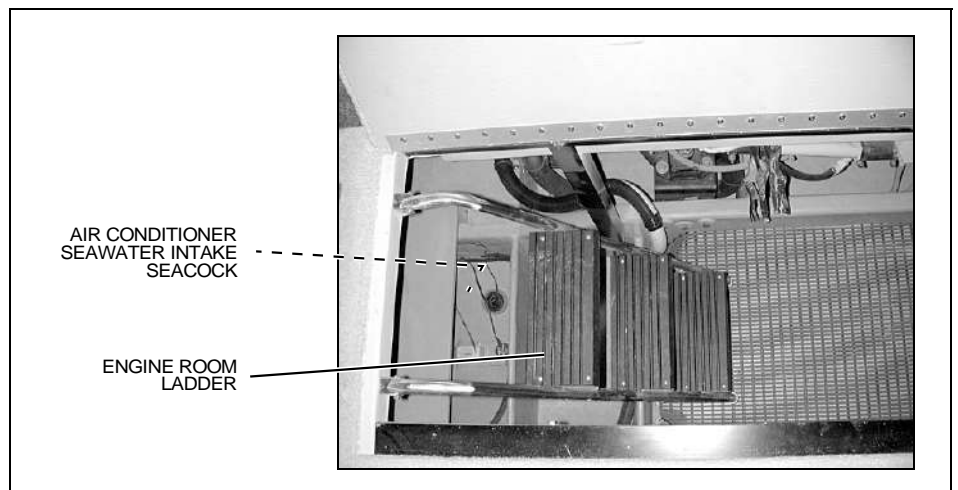

Air Conditioner Unit - V-berth (If Equipped):

- Located in the port storage locker under the V-berth mattress.

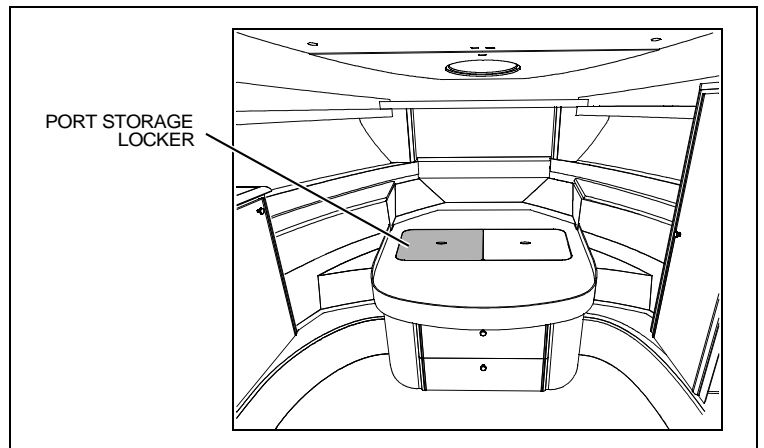

Air Conditioner Unit - Aft Cabin (If Equipped):

- Located in the starboard storage locker under the aft berth mattress.

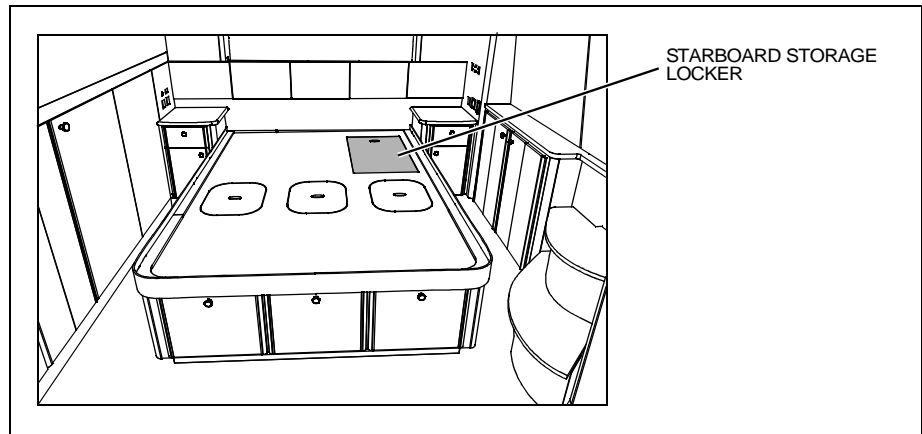

Air Conditioner Units (2) - Command Bridge (If Equipped):

- Located under the command bridge dash.

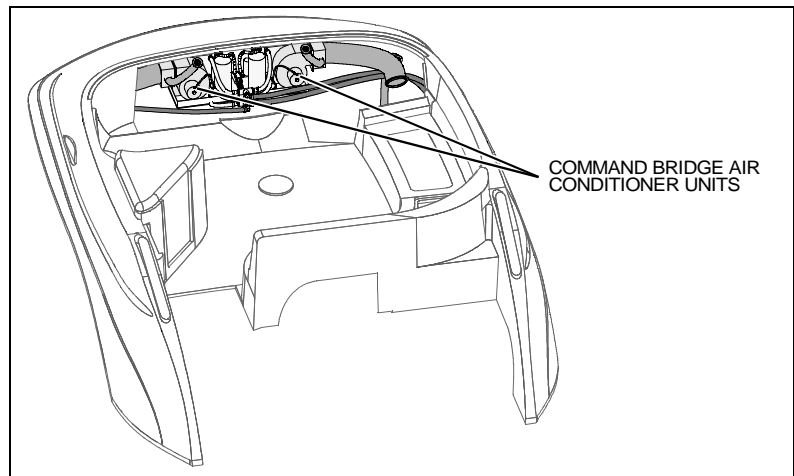

Batteries:

- All batteries except the bow thruster battery are located in the lazarette.
- The bow thruster battery is located in the engine room, forward of the port engine.

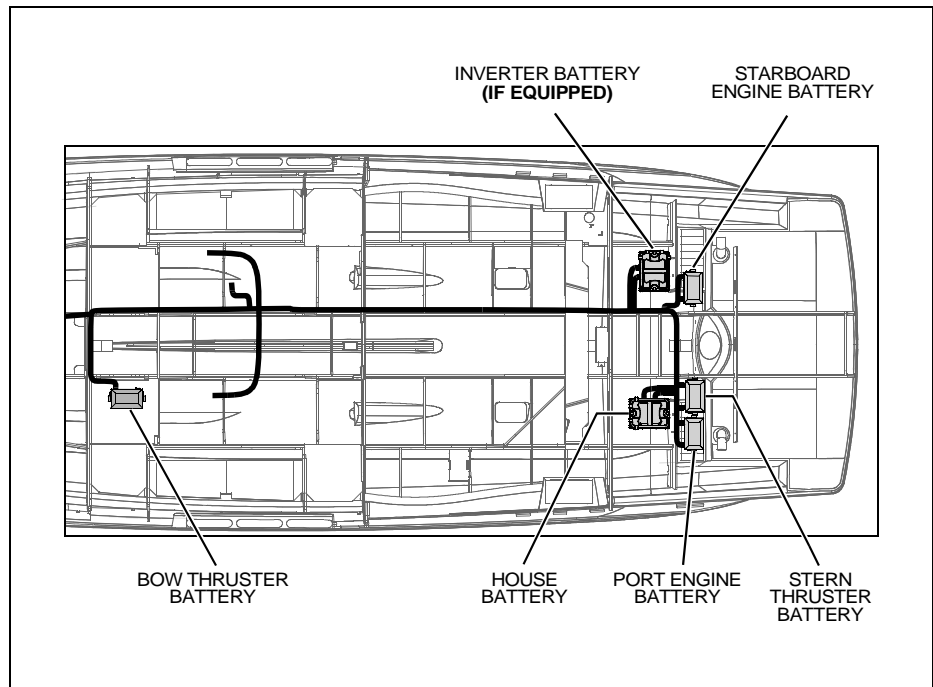

Battery Charger:

- Located on the aft wall in the engine room.

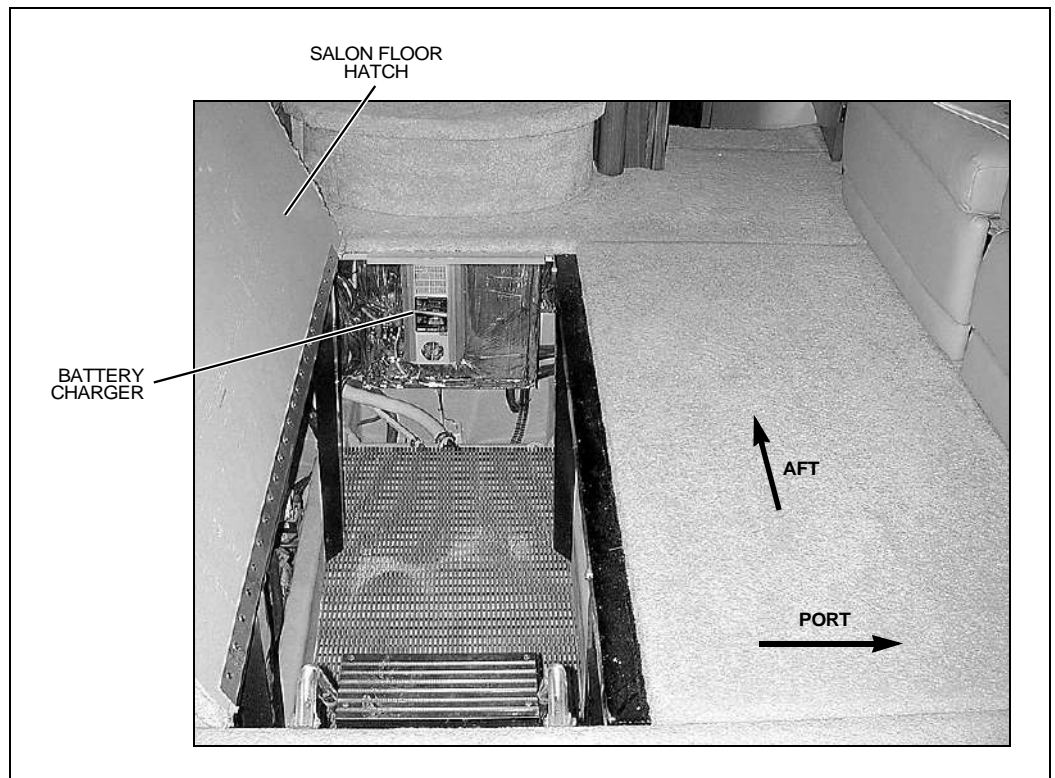

Battery Management Panel (Battery Switches):

- Located in the lower salon cabinet next to the entry steps.

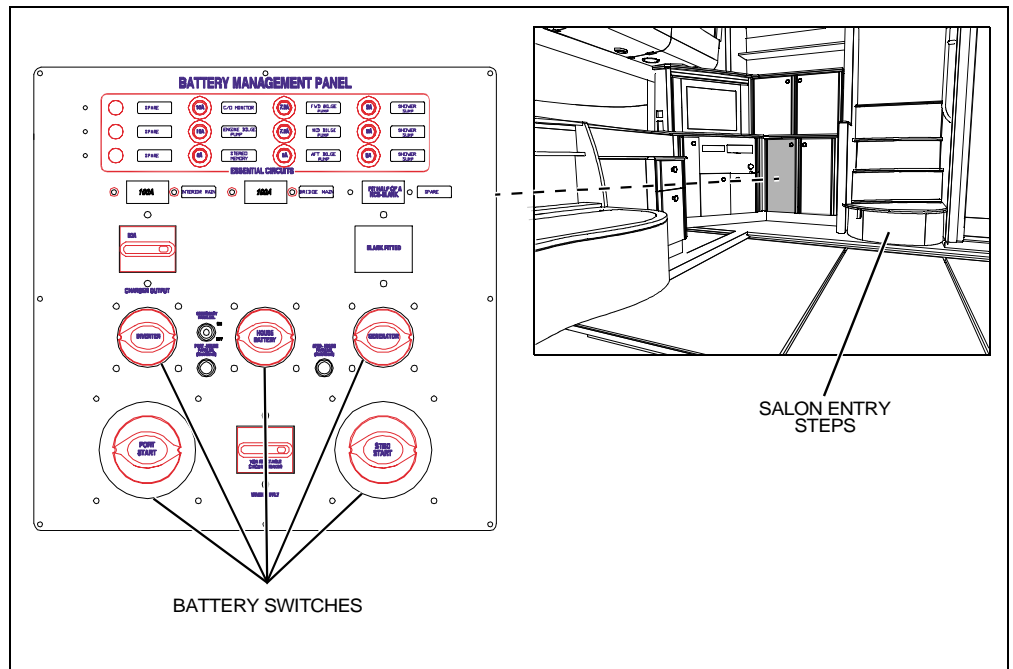

Bilge Pump & Float Switch - Aft:

- Located in the lazarette bilge.

Bilge Pump & Float Switch - Aft-Forward:

- Located in the bilge under the aft cabin.
- Access is through the aft entry step.

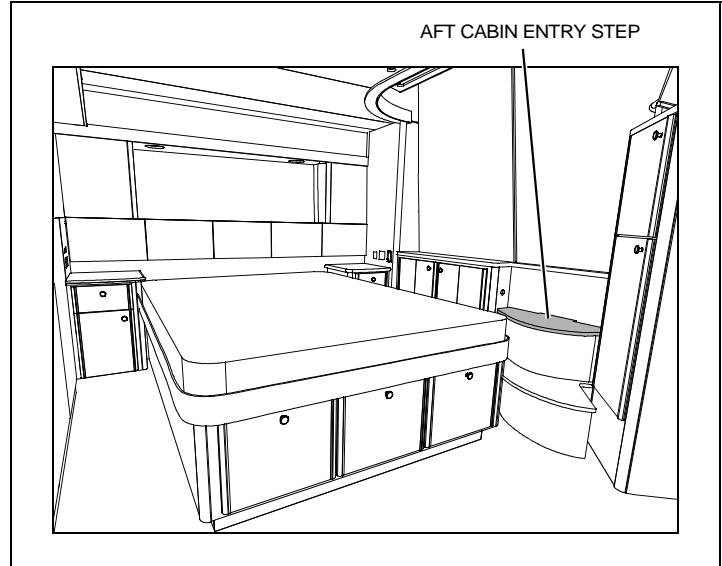
**Bilge Pump & Float Switch - Mid-Aft:**

- Located in the bilge under the aft cabin.
- Access is through the forward floor hatch in the aft cabin.

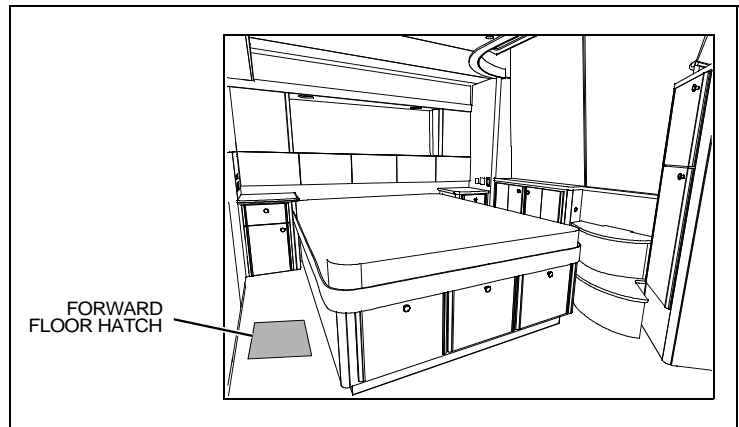
**Bilge Pump & Float Switch - Mid-Forward:**

- Located forward of the engine room ladder.

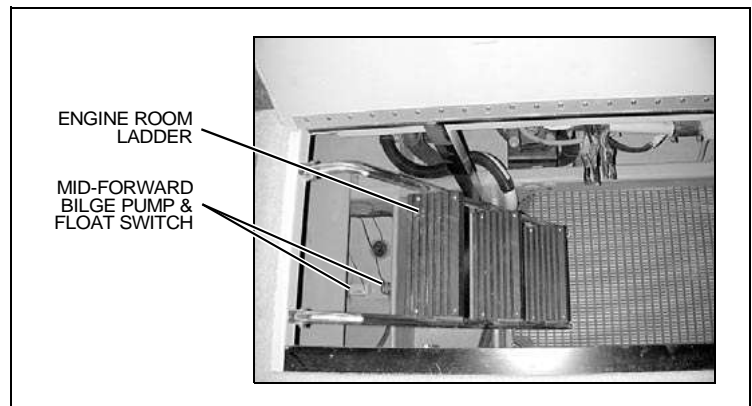

Bilge Pump & Float Switch - Mid:

- Located aft of the waste holding tank in the engine room.

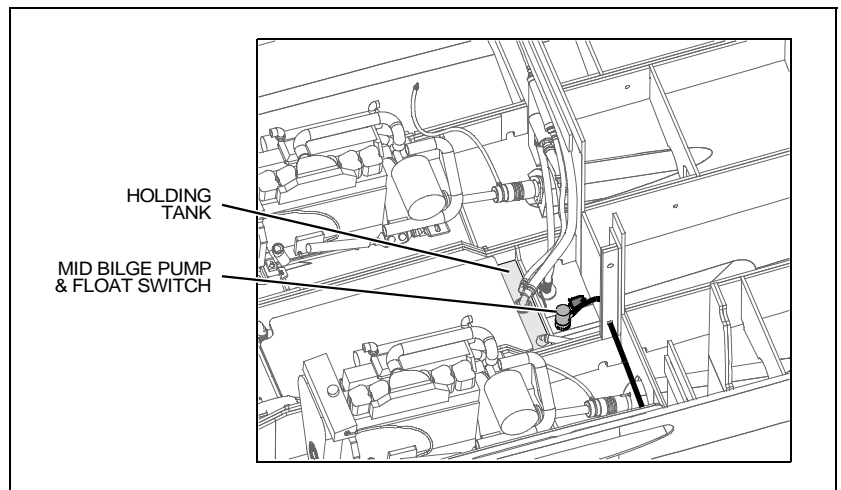
**Bilge Pump & Float Switch - Forward:**

- Located inside the floor hatch in the utility room.
- Access the utility room by lifting up the galley steps.

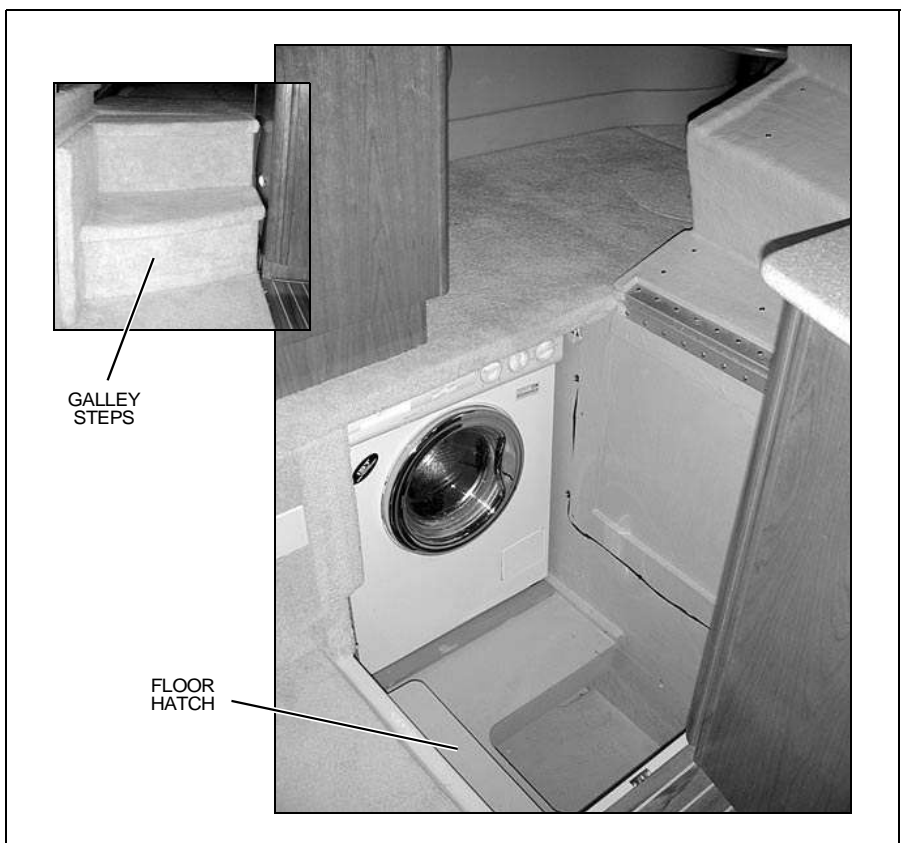

Carbon Monoxide Monitor - Aft Cabin:

- Located on the forward wall.

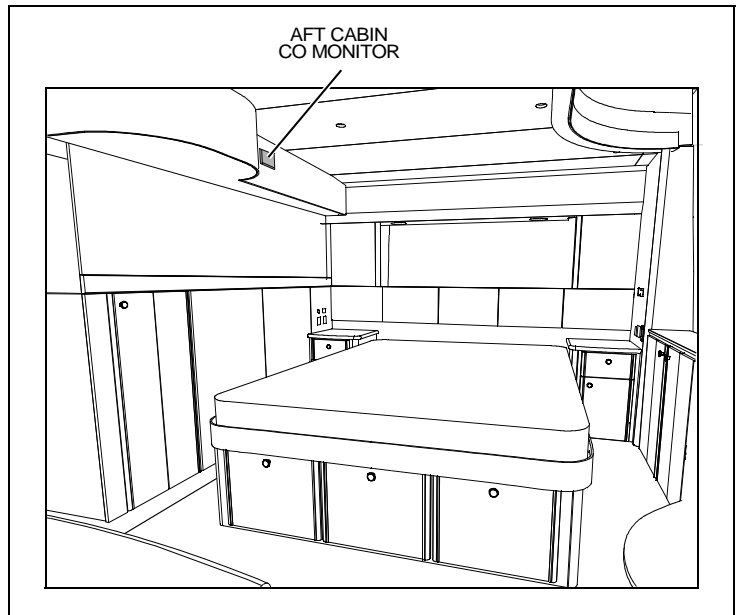

Carbon Monoxide Monitor - Salon:

- Located on the ceiling.

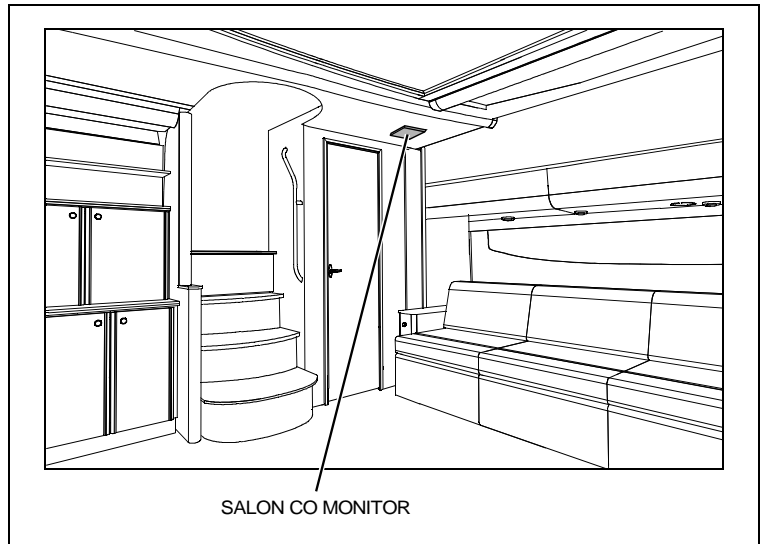

Carbon Monoxide Monitor - V-berth:

- Located on the ceiling.

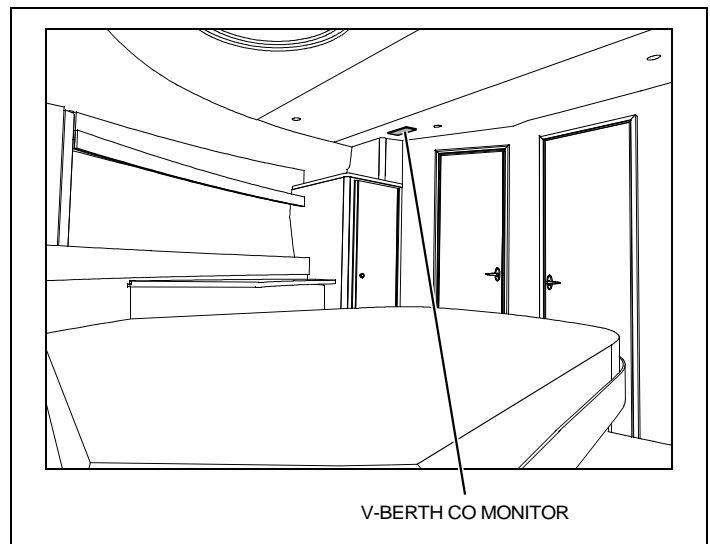

DC Push-To-Reset Breaker Panel:

- Located under the upper helm.

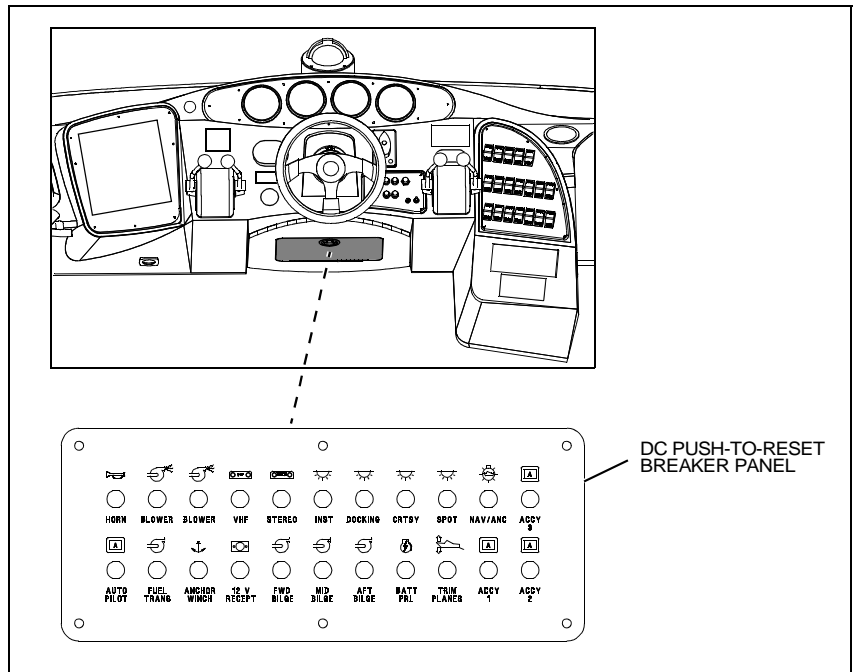

Depth Sounder Thru-hull Transducer:

- Located in the engine room bilge, forward of the engine room ladder.

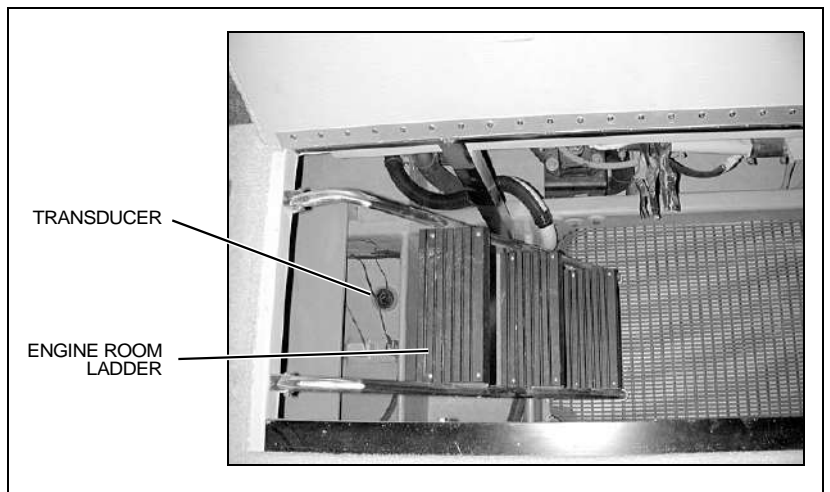

Digital Tank Monitor:

- Located in the upper salon cabinet next to the entry steps.

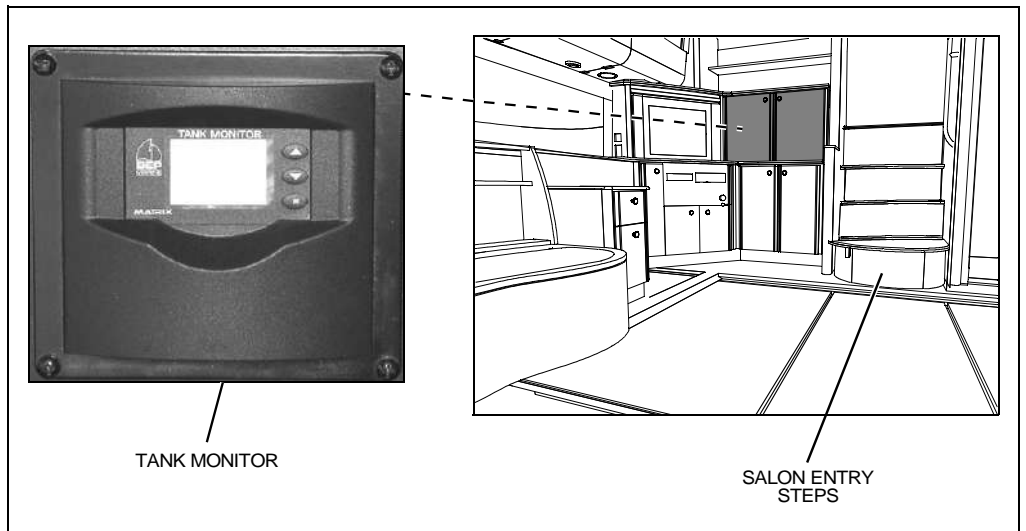

Engine Circuit Breaker:

- Located on each engine.

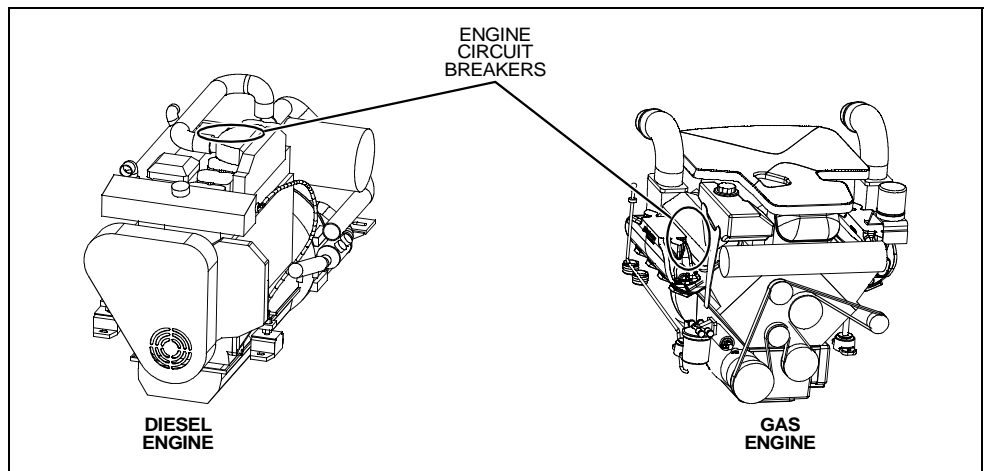

Engine Cooling System Seawater Intake Seacocks:

- Located in the engine room, forward of each engine.

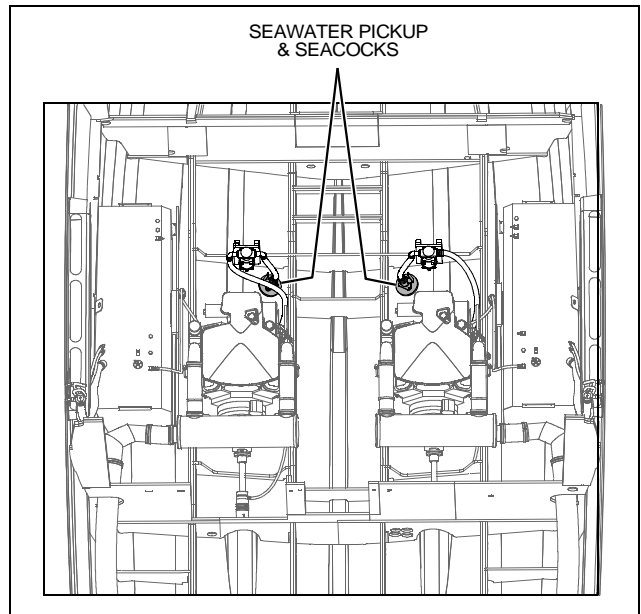

Engine Room Access:

- Access the engine room through the center floor hatch in the salon.

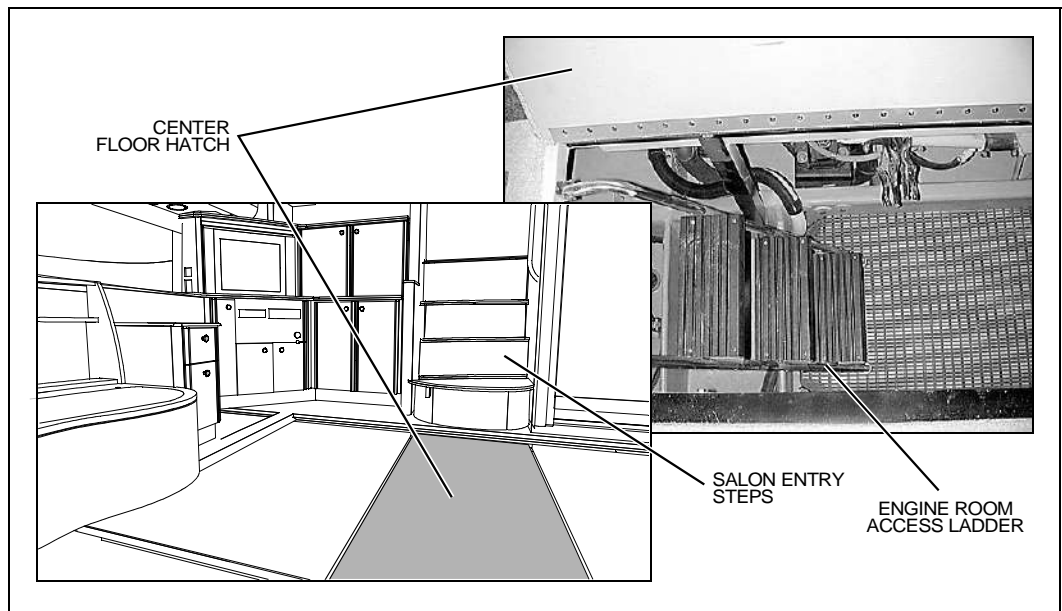

Freshwater Fill Deck Fitting:

- Located on the starboard side of the cockpit, forward of the fender storage hatch.

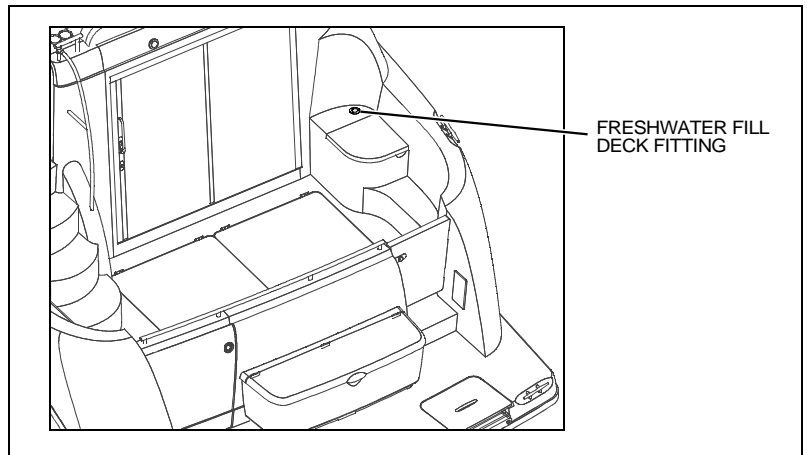

Freshwater Pump:

- Located in the aft cabin.
- Access is through the forward floor hatch.

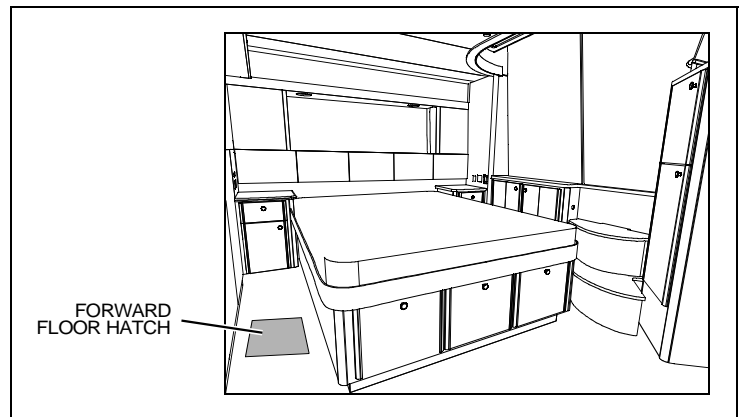

Freshwater Pump Switch:

- Located on the DC panel in the upper salon cabinet next to the entry steps.

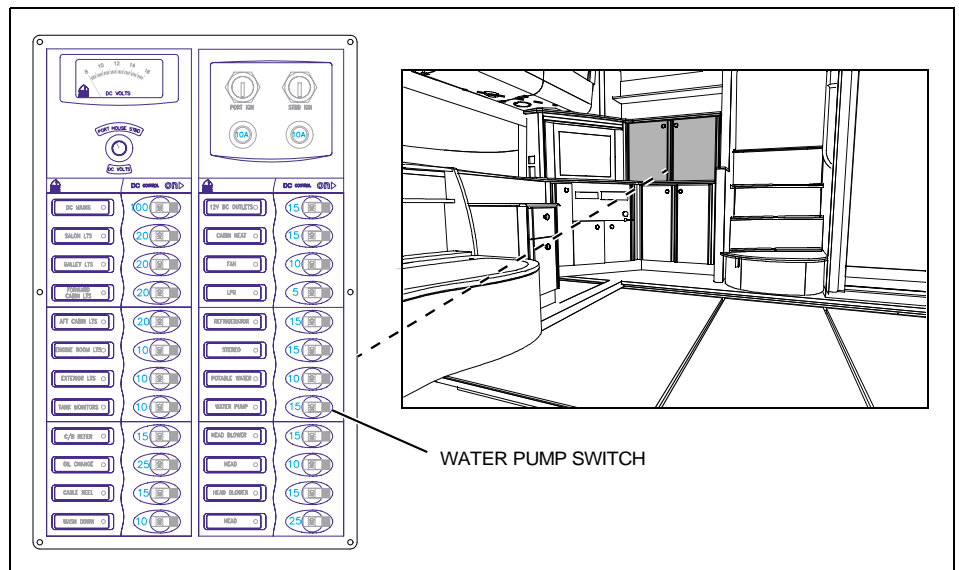

Freshwater Tank:

- Located in the aft cabin.
- Access is through the aft floor hatch or the forward floor hatch.

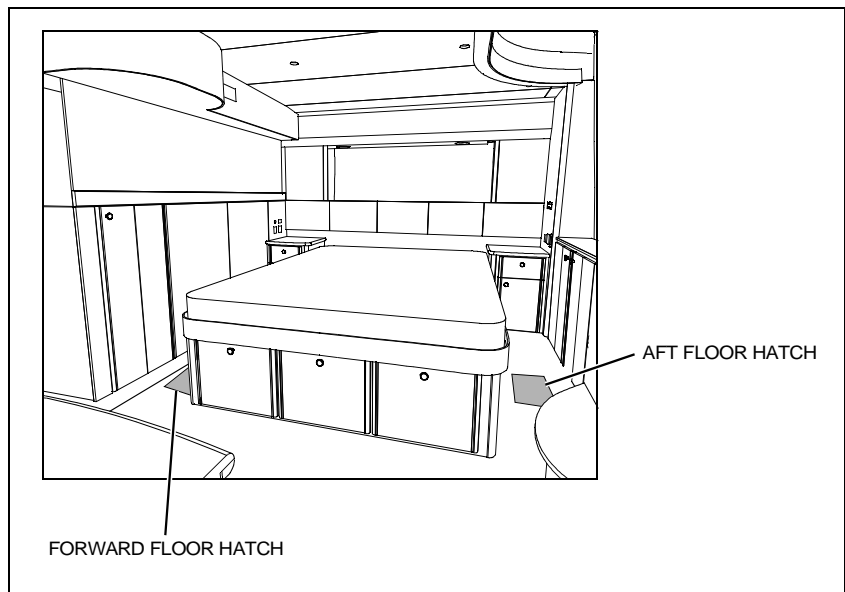
**Fuel Fill Deck Fittings:**

- Located on the port and starboard deck trails.

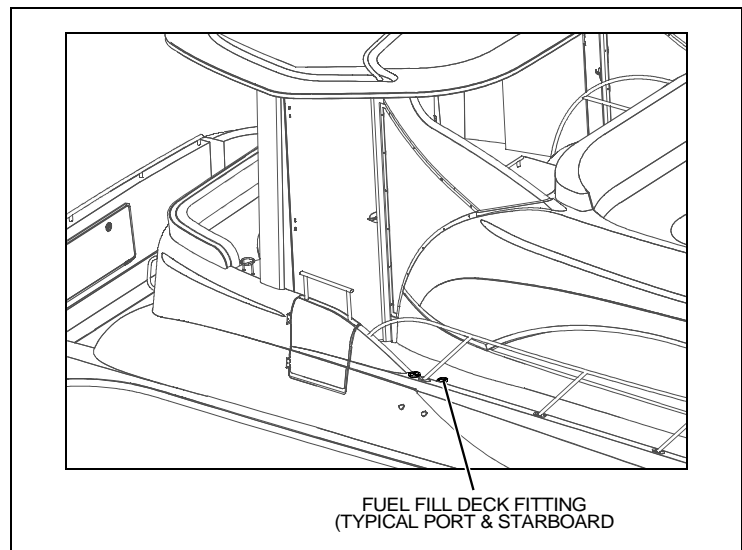
**Fuel Tanks:**

- Located on each side of the engine room.

Generator (If Equipped):

- Located in the lazarette.

Generator Seawater Pickup Seacock (If Equipped):

- Located in the lazarette, aft of the generator.

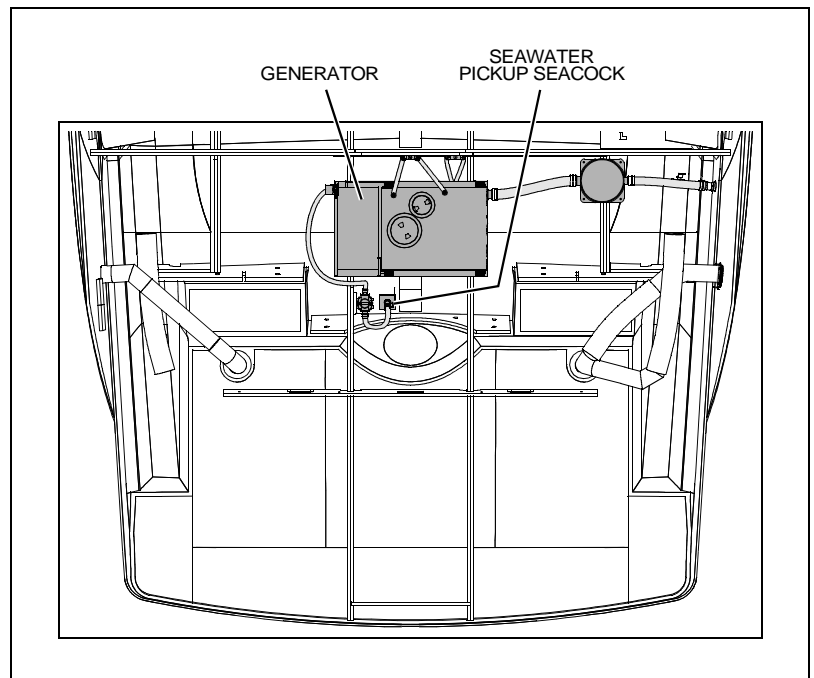
**Heat Exchanger Fan Switch (If Equipped):**

- Located to the left of the galley sink.

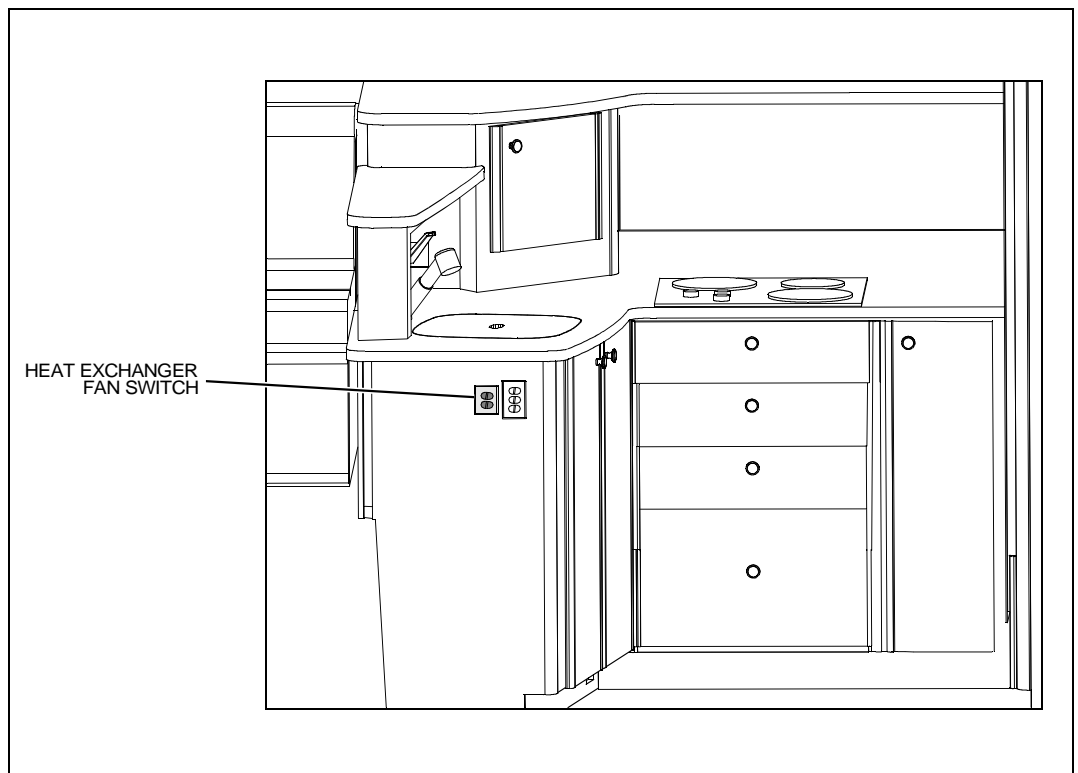

Heat Exchanger Shut-off Valve (If Equipped):

- Located in the engine room, forward of the starboard engine.

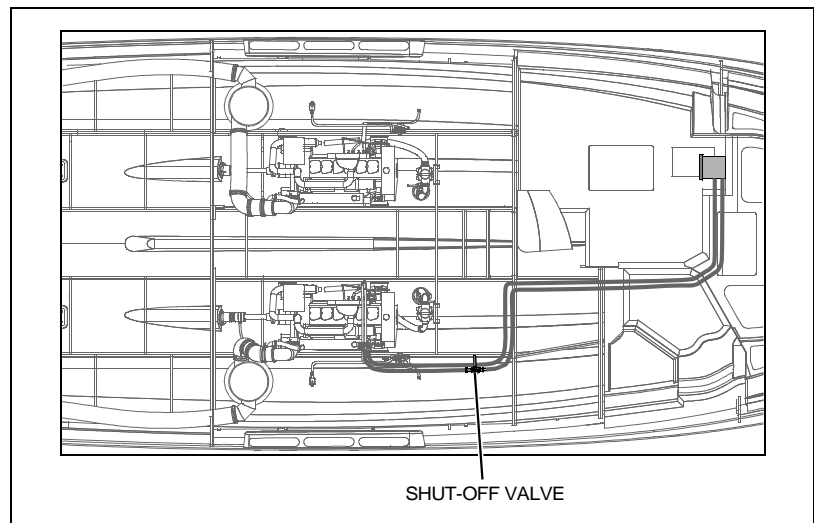

Hydraulic Steering Fluid Reservoir:

- Located on the steering column at each helm.

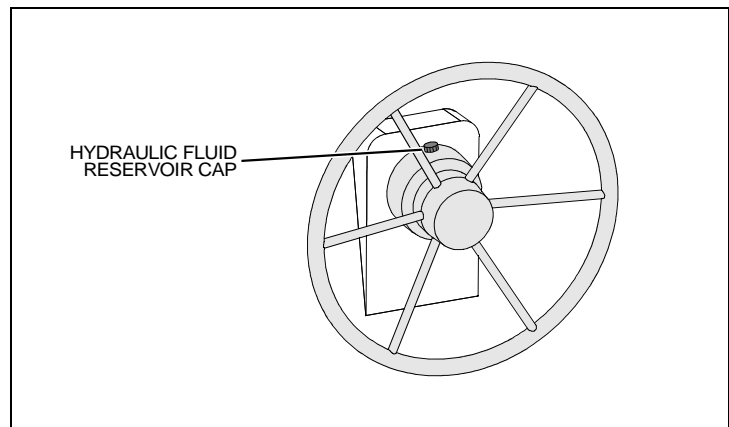

Inverter (If Equipped):

- Located in the aft cabin.
- Access is through the aft entry step.

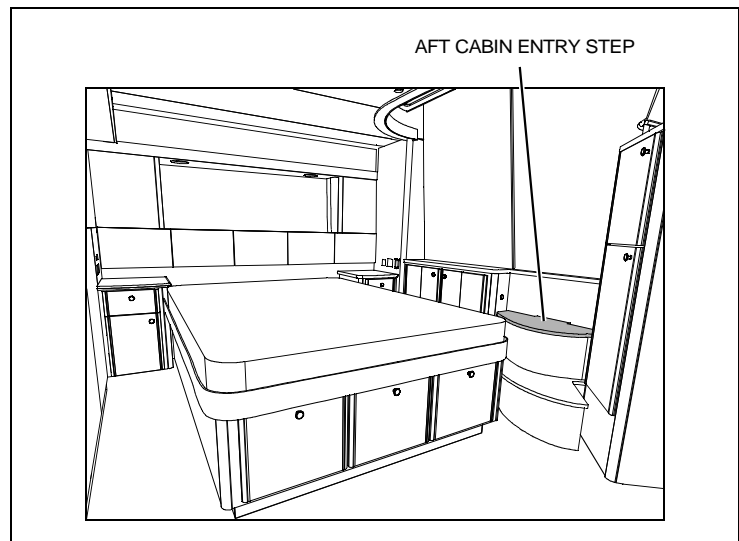

Lazarette:

- Access the lazarette through the cockpit floor hatches.

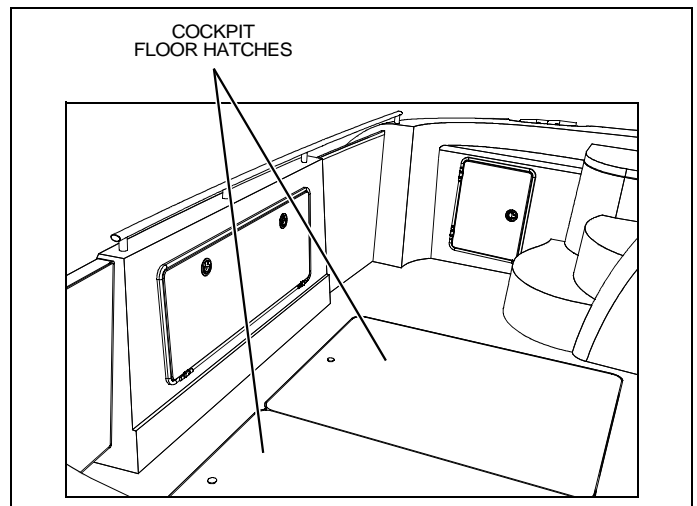
**Macerator Underwater Discharge Seacock (If Equipped):**

- Located in the engine room, aft of the holding tank.

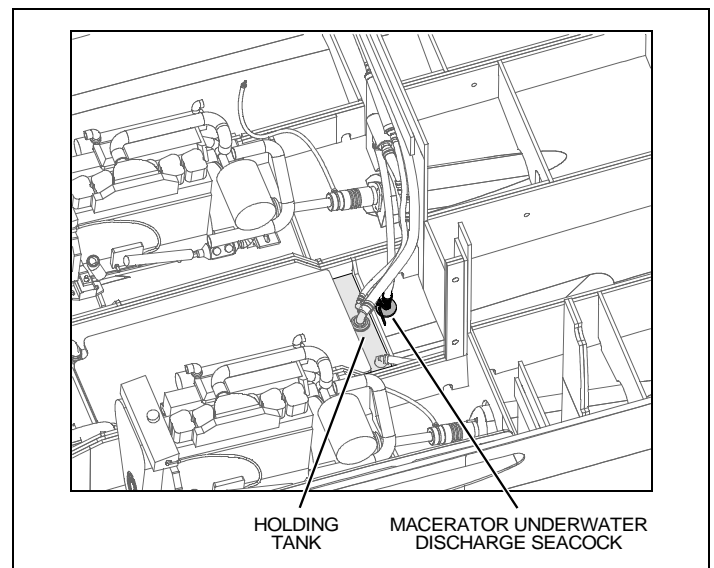
**Seawater Washdown Pickup Seacock:**

- Located inside the floor hatch in the utility room.

Seawater Washdown Pump:

- Located inside the floor hatch in the utility room.



Seawater Washdown Pump Circuit Breaker:

- Located on the DC panel, inside the electrical cabinet.

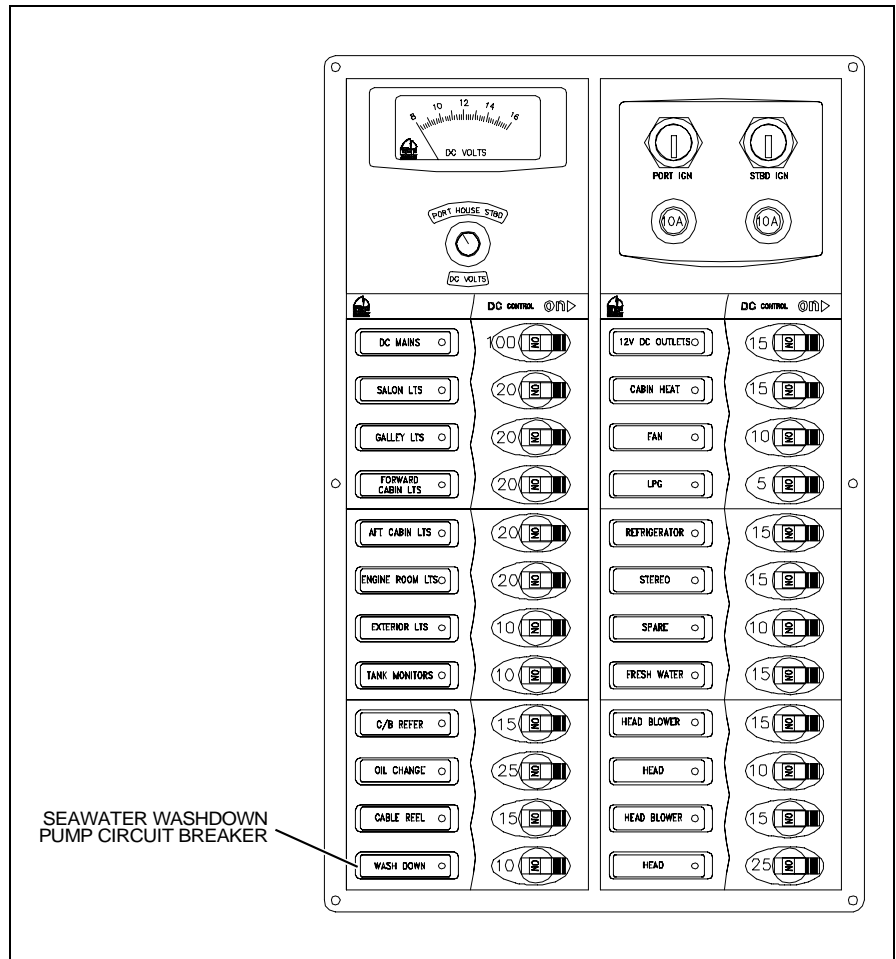

Spotlight:

- Located on the forward deck.

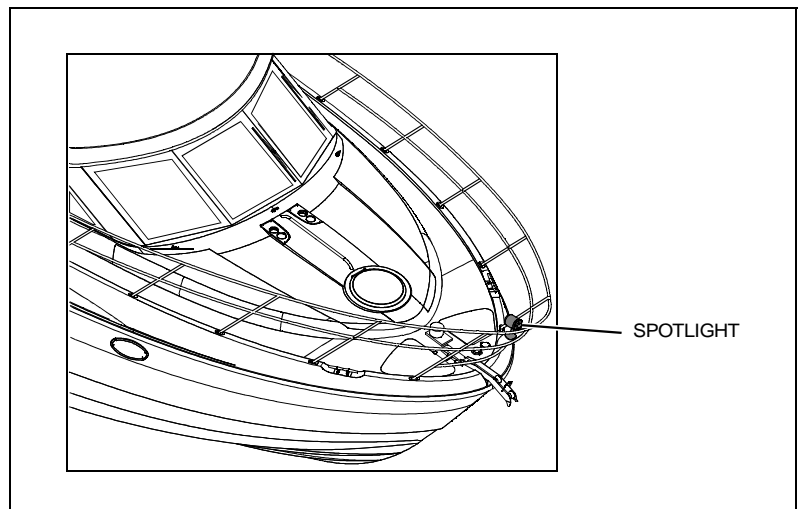

Spotlight Control Panels:

- Located at each helm.

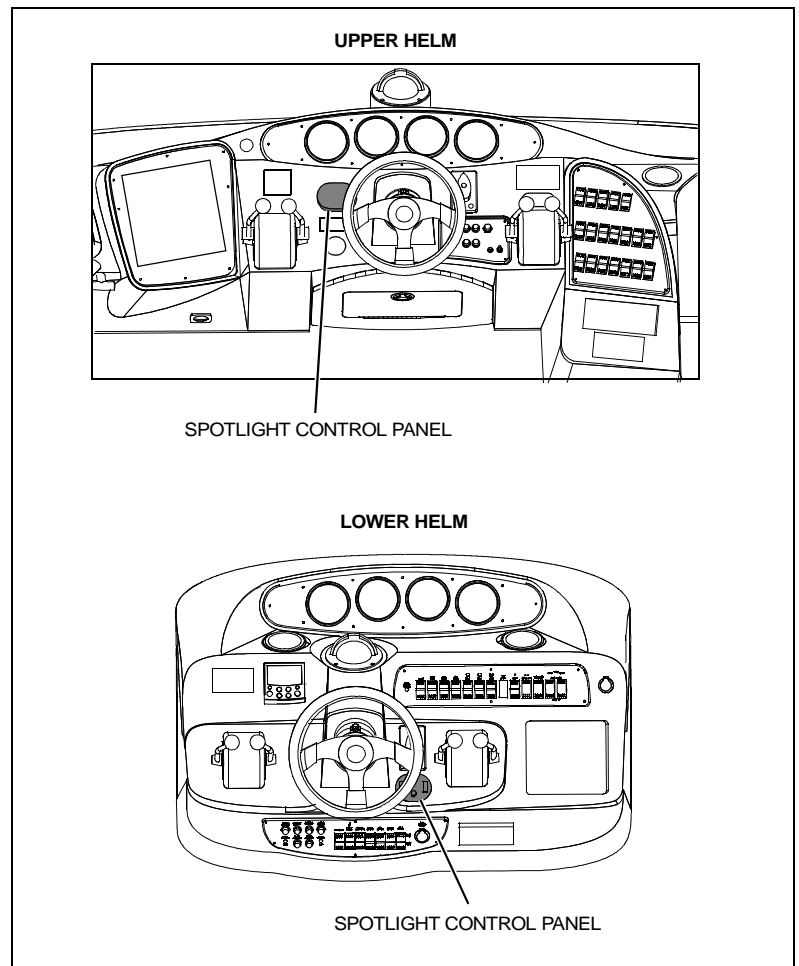
**Sump Pump - Aft:**

- Located in the bilge under the aft cabin.
- Access is through the forward floor hatch in the aft cabin.

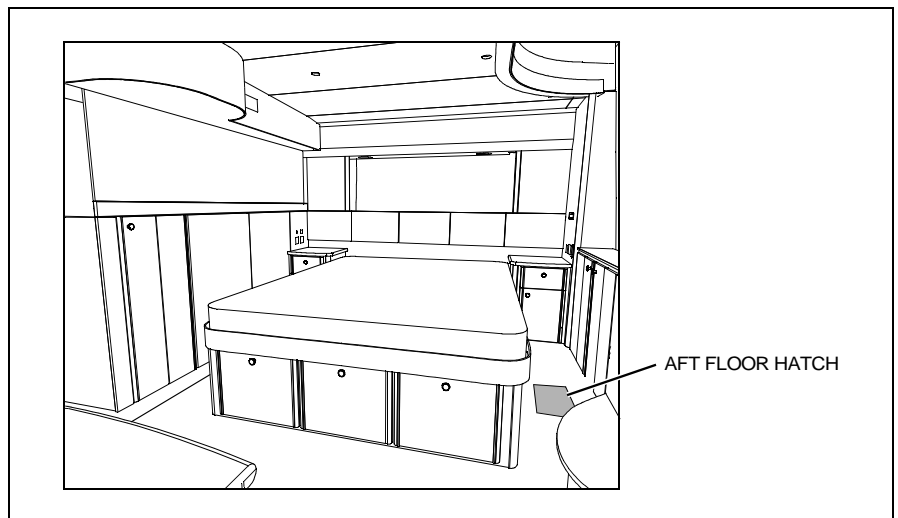

Sump Pump - Forward:

- Located inside the floor hatch in the utility room.

**Trim Tab Hydraulic Fluid Reservoir:**

- Located on the port side of the lazarette, forward of the generator.

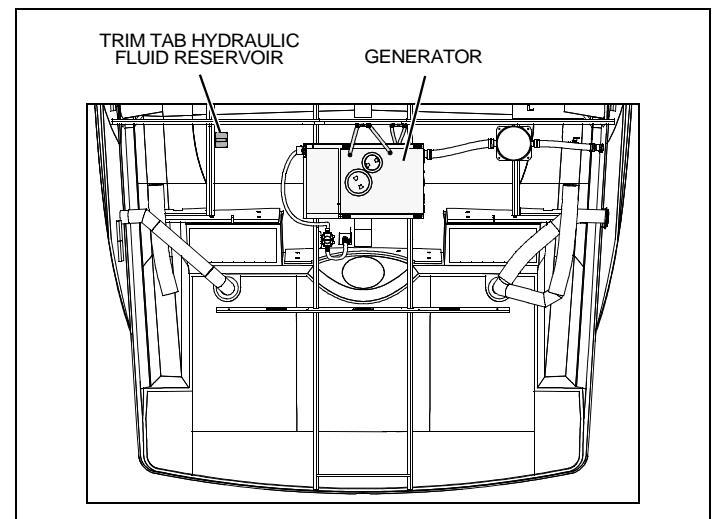
**Wall Vacuum Unit (If Equipped):**

- Located in the utility room on the forward starboard wall.

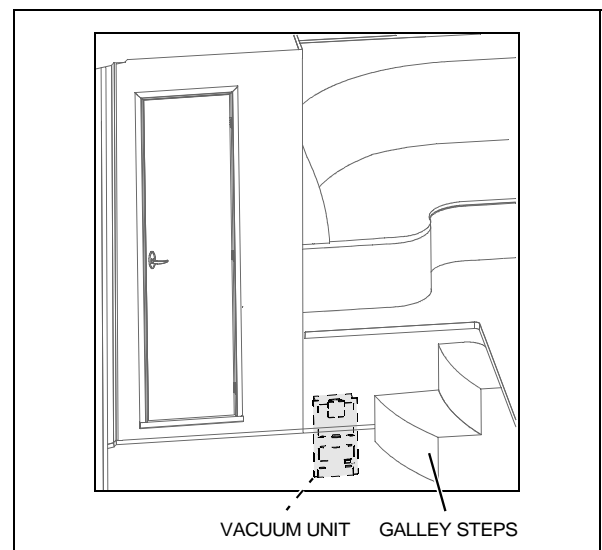

Waste Holding Tank:

- Located in the engine room.

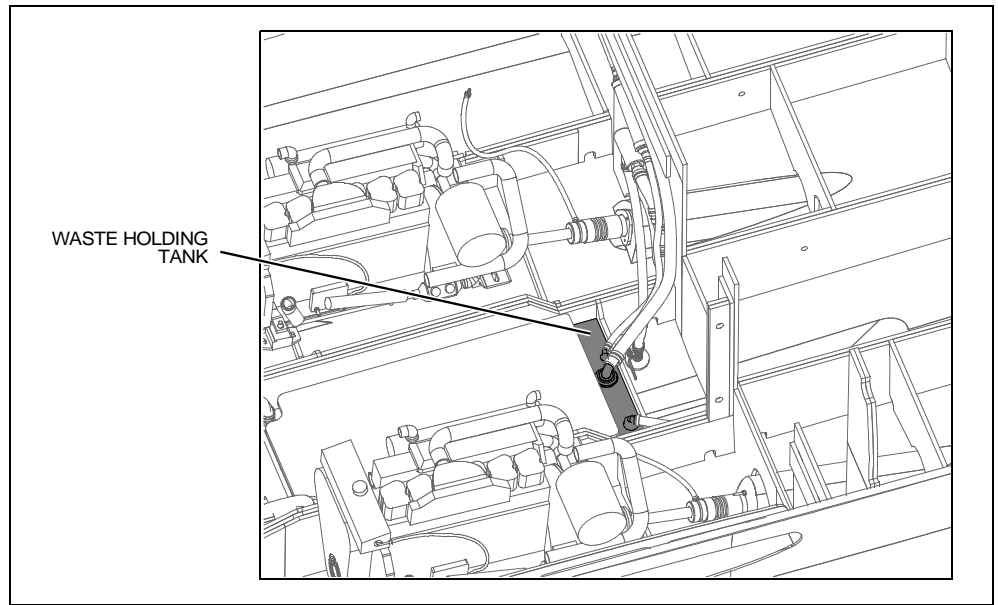
**Water Heater:**

- Located in the engine room, forward of the port fuel tank.

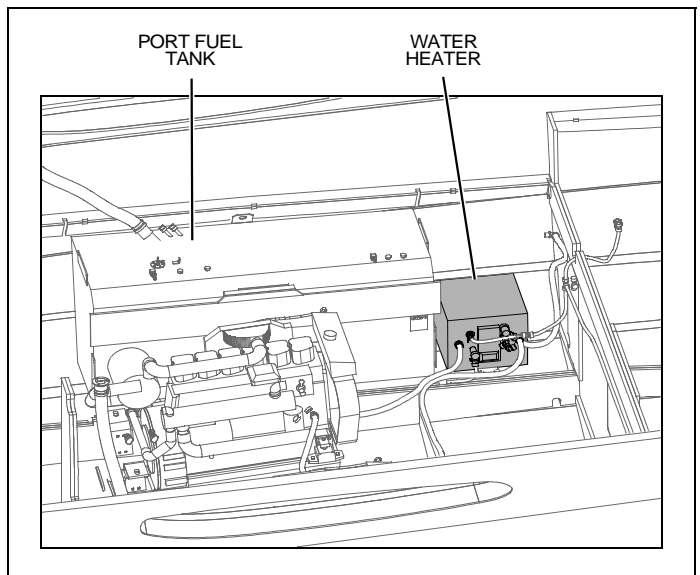
**Windshield Washer Fluid Reservoir (If Equipped):**

- Located on the forward bulkhead, on the starboard side of the engine room.

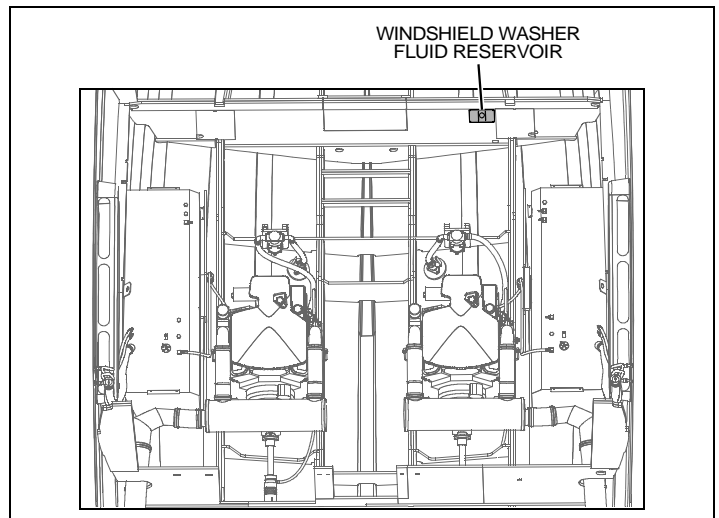

Chapter 3: Propulsion & Related Systems

Engines

Read the engine operation and maintenance manuals *before* starting or doing any maintenance on the engines.

Engine Cooling System



CAUTION

SYSTEM DAMAGE HAZARD!

The engine cooling system's seacocks for both engines *must be Opened before the engines are started. And they must remain Open while the engines are running.*

The engine cooling system circulates seawater through the engines and also uses a freshwater cooling system to reduce engine temperatures.

- Make sure the seawater intake seacock for each engine is **Open** *before* starting the engines and keep the seacocks **Open** while the engines are running.
- The cooling system's seawater strainers should be checked for leaks and debris *every time* you use your yacht.
- For instructions on how to clean the seawater strainers, see the *Seawater Systems* section of this *Owner's Manual*.

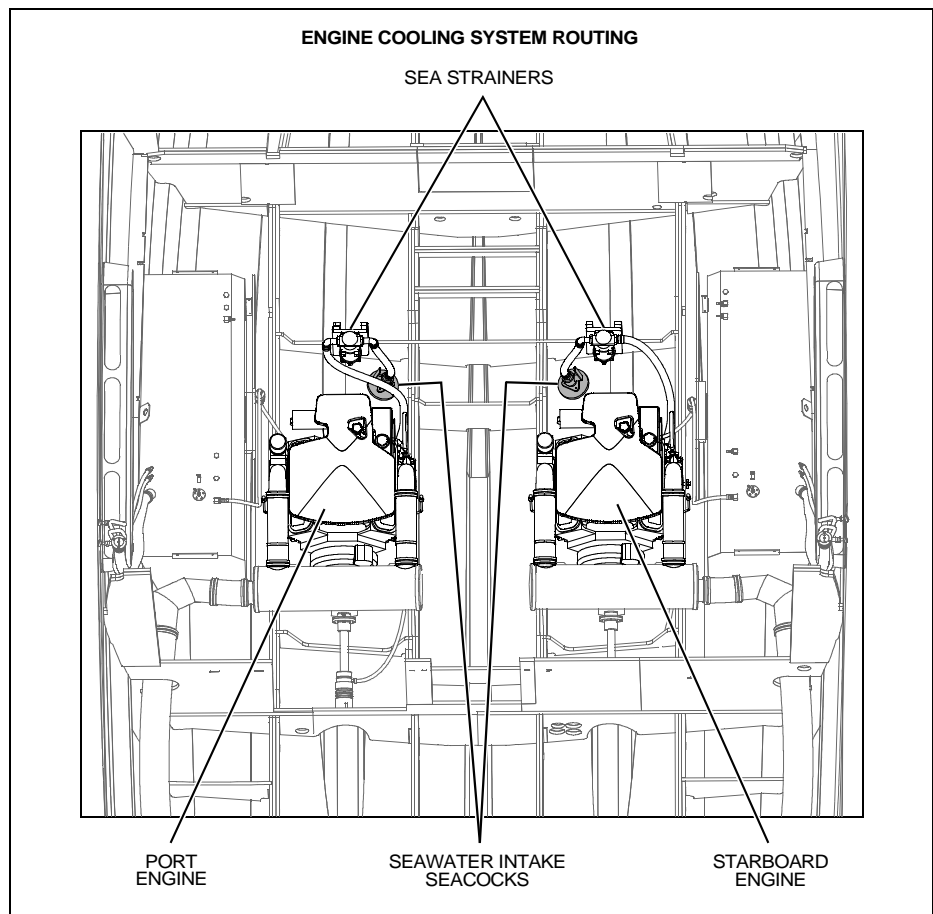

Exhaust System

⚠ **DANGER!**



CARBON MONOXIDE POISONING HAZARD!

Leaking engine and/or generator exhaust is a source of dangerous carbon monoxide gas (CO).

- Check *all* exhaust systems *before* each trip.
- Look for leaks in the exhaust systems of the engines and the generator.
- Look for discoloration, water leaks, carbon or stains around *all* joints.
- Make sure *all* of the exhaust clamps are in place and secured.

- Make sure the ventilation systems work and are *NOT* obstructed or restricted.
- To reduce the chance of CO entering the living spaces, fill any gaps around engine room plumbing, cableways, exhaust systems, doors, hatches, and access panels.

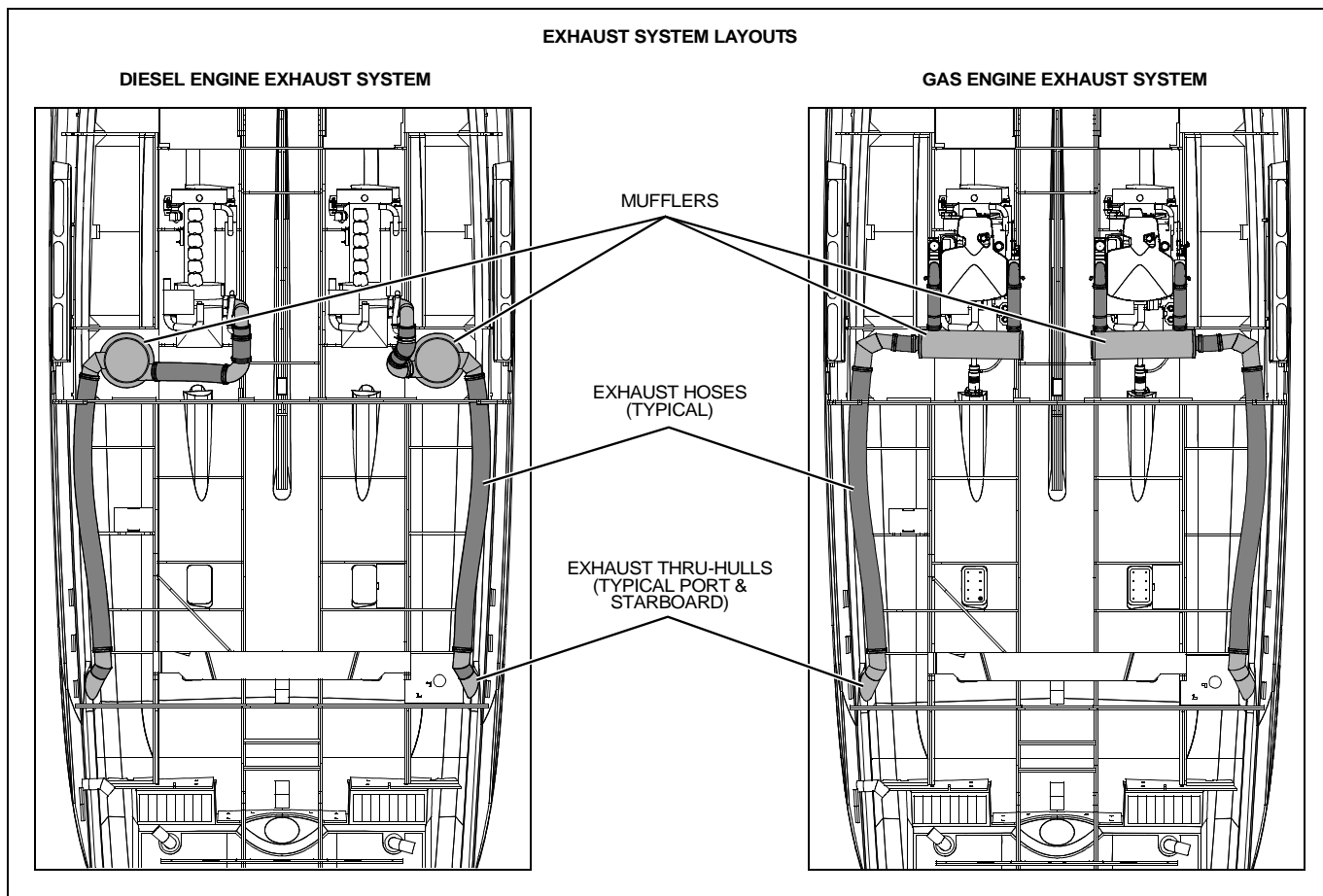

- *Always* consider the sea conditions *before* anchoring or shutting *Off* the engines.
- The exhaust system is designed to keep seawater out of the engines in most sea conditions.
- However, do *not* anchor the stern to sea or shut the engines *Off* if high seas might flood the exhaust system.

Bilge Blower Systems

! **WARNING!**



FIRE/EXPLOSION HAZARD

- Use of the blower system is *NOT A GUARANTEE* that explosive fumes have been removed.
- *BEFORE* starting the engines or the generator *ALWAYS* use the "sniff test" to check the bilge areas for fuel vapors.
- If you smell fuel, do *NOT* start the engines or the generator and do *NOT* turn *On* any electrical devices.
- If you smell fuel and the engines and/or generator are already running, shut *Off* the engines and/or generator and turn *Off all* electrical devices. Investigate *immediately*.
- Do *NOT* obstruct or modify the ventilation system.

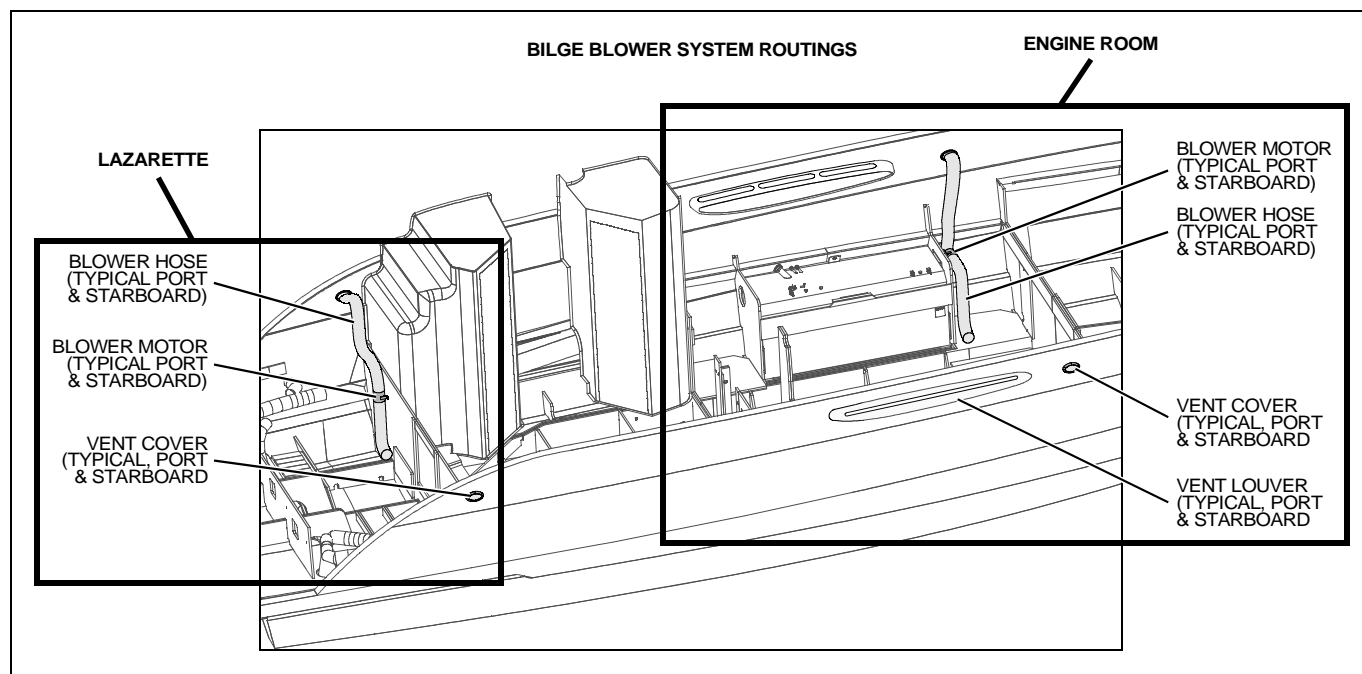



- The bilge blowers remove explosive fumes from the engine room and lazarette bilge areas.
- Fresh air is drawn into these compartments through the vents.

To make sure the bilge areas are properly ventilated:

- *Always* run the bilge blowers for at least four minutes *before* starting the engines or the generator (if equipped).
- Use the "sniff test" to check the bilge areas for fuel vapors *before* starting the engines or the generator.
- Continue to run the blowers until your yacht has reached cruising speed.
- *Always* run the blowers when operating the yacht below cruising speed.

Fuel System

 WARNING!	
FIRE, EXPLOSION AND OPEN FLAME HAZARD!	
	
<ul style="list-style-type: none"> • It is very important that the fuel system be inspected thoroughly the first time it is filled and at each subsequent filling. • Read the fueling instructions in the engine operation manual and the <i>Cruiser & Yacht Owner's Manual Supplement</i>. 	

 CAUTION	
Avoid the storage or handling of gear near the fuel lines, fittings and tank.	

 CAUTION	
SYSTEM DAMAGE HAZARD!	
Use of any methanol, gasohol, or alcohol based fuel additive will damage the fuel system.	

NOTICE	
<ul style="list-style-type: none"> • On diesel engine models, air in the diesel supply system can stop an engine or severely restrict performance. • If you suspect air in the fuel lines, refer to your engine operation manual for detailed instructions on how to <i>bleed</i> the system. 	

NOTICE	
Carefully read the fuel section of both the <i>Cruiser & Yacht Owner's Manual Supplement</i> and the engine operation manual, paying special attention to the subject of <i>fuel recommendations</i> .	

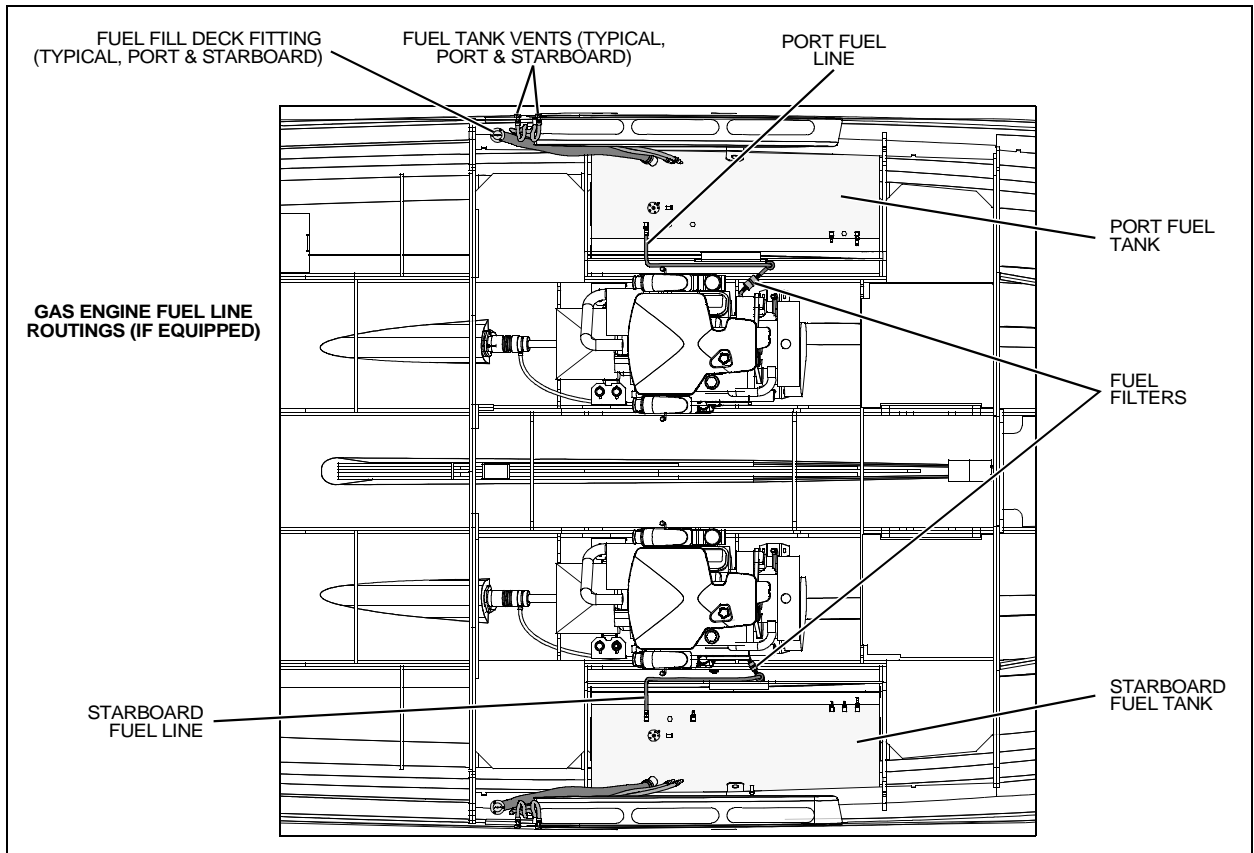
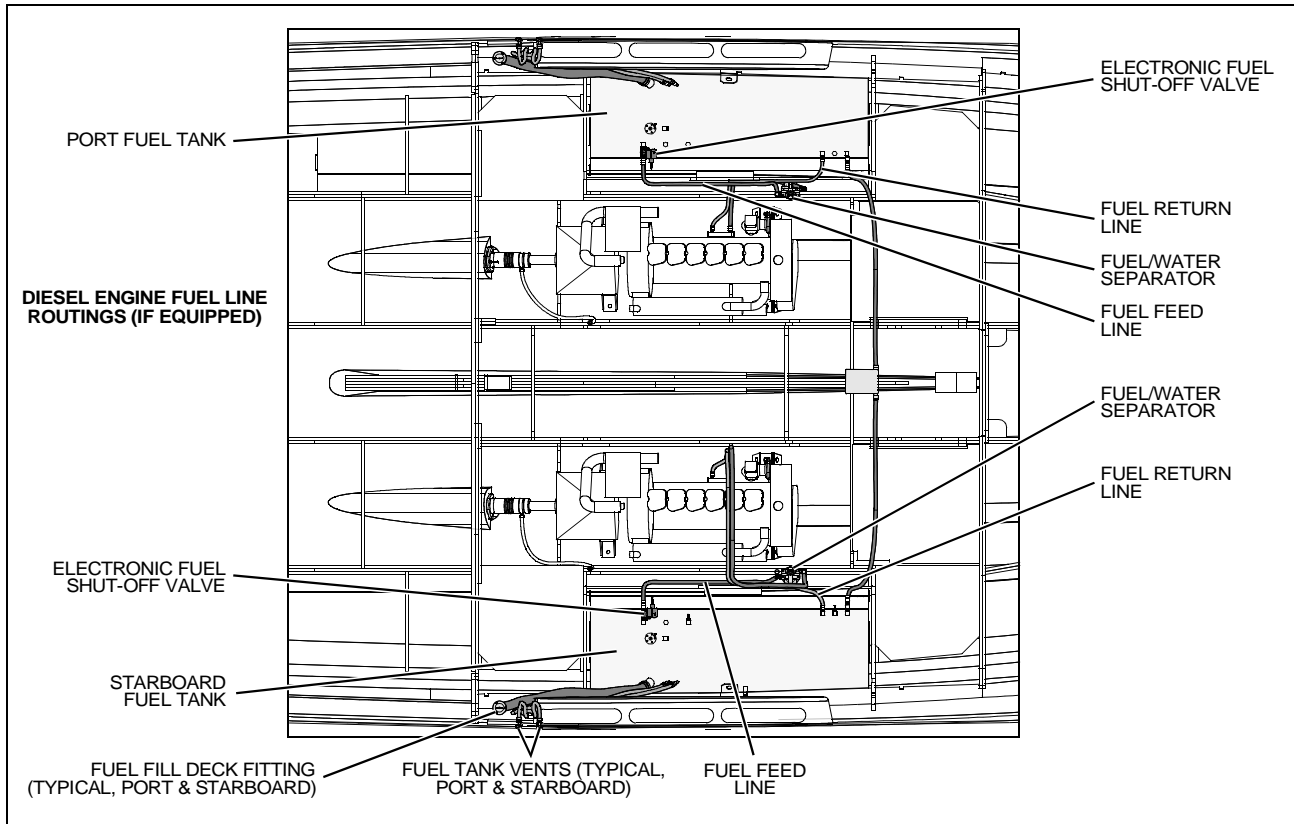

Fuel Fills & Vents

- The fuel fill fittings are marked Gas or Diesel.
- If you have problems filling either fuel tank; see if the fuel fill hose or fuel tank vent hose is kinked or collapsed.
- If there are no visible signs of a problem, contact your local dealer.

Anti-siphon Valves (Gas Engines Only)

NOTICE

- **If an engine running problem is diagnosed as fuel starvation, check the anti-siphon valve.**
- **If the valve is stuck or clogged, change or replace it while the engine is *shut down*.**
- ***NEVER* run either engine with its anti-siphon valve removed, except in an emergency.**

- The anti-siphon valves are vital fuel system parts.
- If a fuel line ruptures, this valve will prevent the fuel from siphoning from the tank.
- The valves are located on the fuel tanks, where the fuel feed lines attach to the tanks.
- These valves are spring loaded and are opened by fuel pump vacuum.

Electronic Fuel Shut-off Valves (Diesel Engines Only)

- Your diesel engines are equipped with electronic fuel shut-off valves.
- When you start your engines, the electronic fuel shut-off valves turn **On** (open) to allow fuel to the engines.
- When you turn off the engines, the electronic fuel shut-off valves turn **Off** (close), stopping the fuel from going to the engines.
- If one of the electronic fuel shut-off valves malfunction, it has a manual override.
- Turn the manual override clockwise to open the electronic fuel shut-off valve.

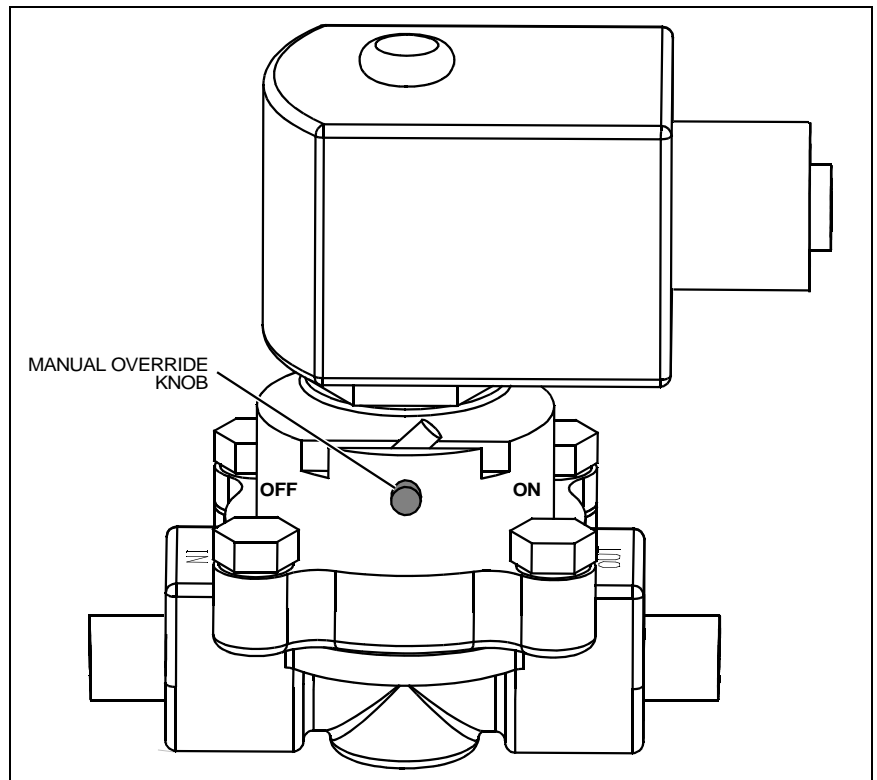

Gas Engine Fuel Filters

- The fuel pickup tube located inside each fuel tank is equipped with a fine mesh screen filter.
- In addition, a fuel filter is installed on the fuel line.
- Periodically replace the fuel filters to make sure they remain clean and free of debris.
- Talk to your selling dealer or local marina about fuel additives that help prevent fungus or other buildup in your fuel tanks.

Fuel Filter/Water Separators (Diesel Engines Only)

NOTICE

Refer to the fuel filter/water separator manual for important service instructions.

Fuel Transfer Pump (Diesel Engines Only) (If Equipped)



CAUTION

ENVIRONMENTAL HAZARD!

- **NEVER** transfer fuel into a full (or nearly full) fuel tank.
- Fuel transferred into a full tank may spill overboard through the tank venting system.

The fuel transfer pump can be used to transfer fuel to a nearly empty tank or to equalize the fuel level in each tank.

1. The house battery switch must be turned **On** for the fuel transfer pump to run.
2. **Before** transferring fuel, check the fuel gauges to make sure that fuel is not about to be transferred into a full (or nearly full) tank. For accuracy, check the fuel gauges when the boat is **not** underway.
3. After checking the fuel levels, hold the fuel transfer switch **On** to the side you want to pump fuel to.
NOTE: This switch must be **held On** throughout the entire fuel transfer process.
4. When the desired amount of fuel has been transferred, release the switch.
 - If, after following the above instructions, the fuel transfer pump does not run, check the pump's push-to-reset breaker on the DC push-to-reset breaker panel (for the location of this panel, see Chapter 2 of this *Owner's Manual*).
 - If the pump is running, but you are having problems transferring fuel, see if the fuel transfer hose or fuel tank vent hose is kinked or collapsed. If there are no visible signs of a problem, contact your local dealer.

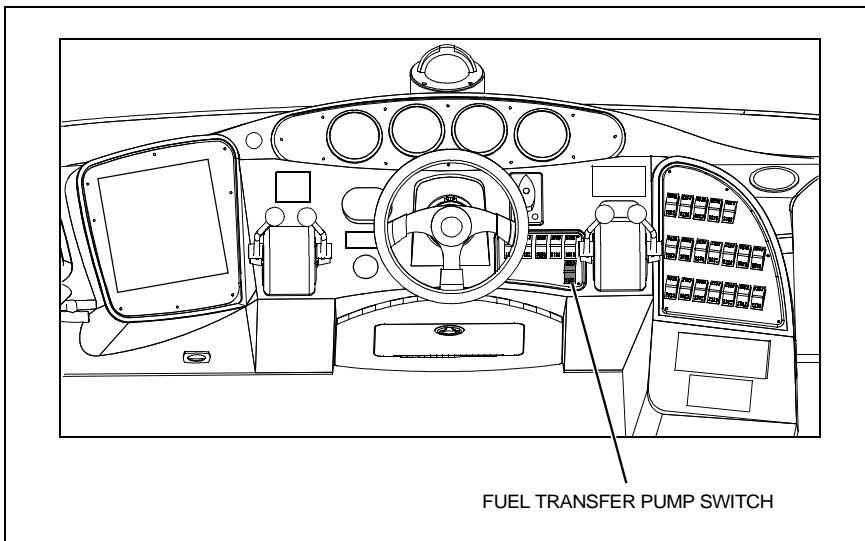

FUEL TRANSFER PUMP SWITCH

Oil Change System (If Equipped) (Diesel Engines Only)

- The oil change system makes it easier to drain and refill the engine oil.
- Read the oil change system instructions for information on the use of this system.

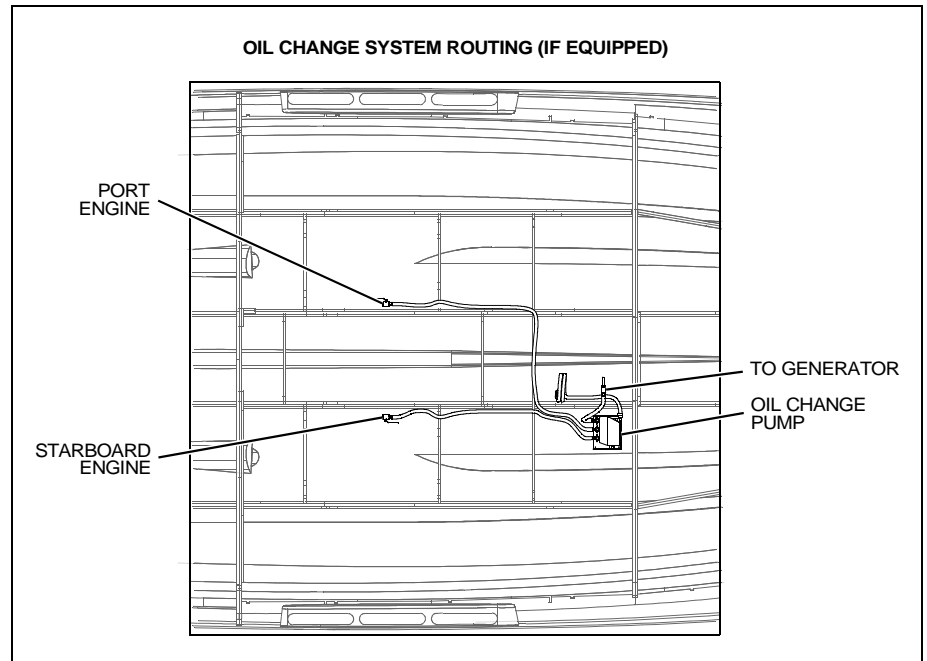

Fire Suppression System (If Equipped)

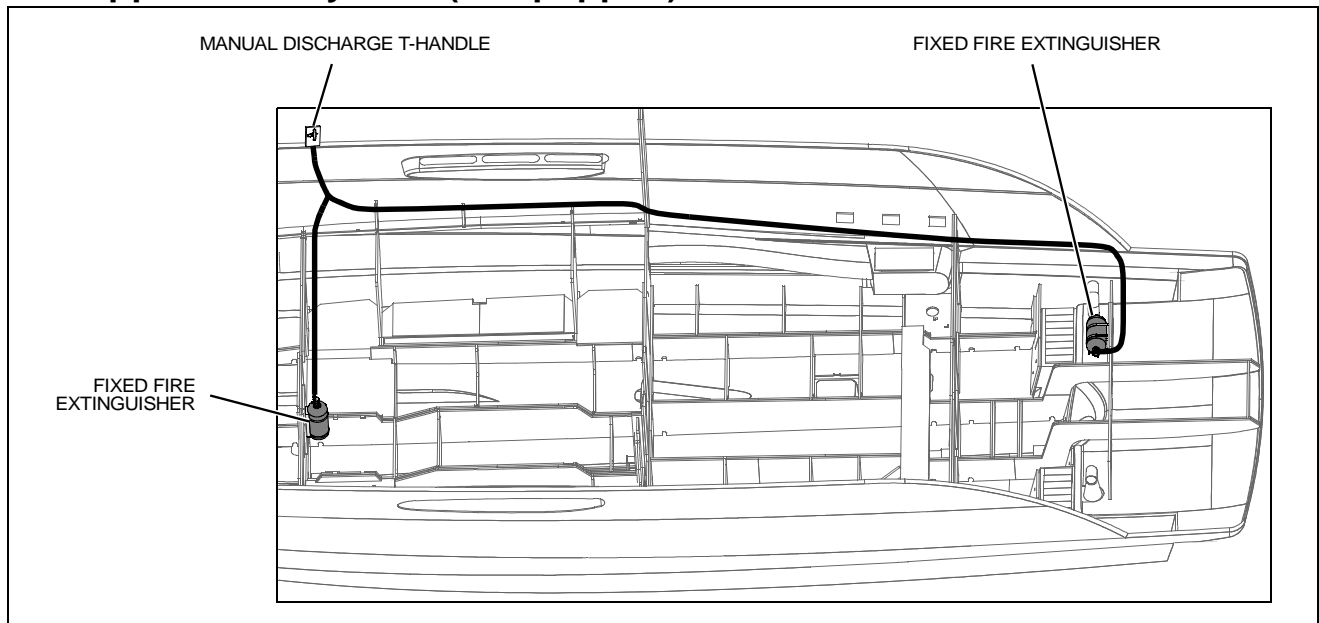

- The fire suppression system is designed to extinguish engine room fires.
- **Before** using your yacht for the first time, read the fire suppression system's instruction and maintenance manual and follow **all** warnings.
- The system will discharge automatically whenever direct heat from a fire is detected in the engine room.
- The system can be discharged manually by pulling the T-handle (labeled "FIRE") at the helm.
- The system can **only** be discharged **once**.
- After the system is discharged it **must** be refilled and refurbished **before** it can be used again.

Shaft-Transmission Alignment



CAUTION

SYSTEM DAMAGE HAZARD!

- If you suspect a shaft-transmission alignment problem, have a qualified mechanic inspect the alignment as soon as possible.
- Continued use may lead to premature engine, transmission, shaft, shaft seal and/or hull damage!

Alignment between the engine transmission output shaft and the propeller is critical. The alignment was performed at the factory and was rechecked by the dealer after the yacht had been in the water for 48 hours.

- An alignment inspection should be performed by a marine mechanic as part of the routine maintenance program after the initial 30 hours of operation, then every 60 hours and whenever unusual noise or vibration is noticed.
- Shaft-transmission alignment should be performed by a marine mechanic since it requires moving the engine and prop shaft.
- To insure proper alignment after a haul out or dry storage, wait 48 hours after launching *before* final alignment adjustments by a marine mechanic are made.

Shaft Log Packless Sealing System

The shaft log packless sealing system's shaft seal is a maintenance-free, water-tight seal that does not require packing or adjustments.

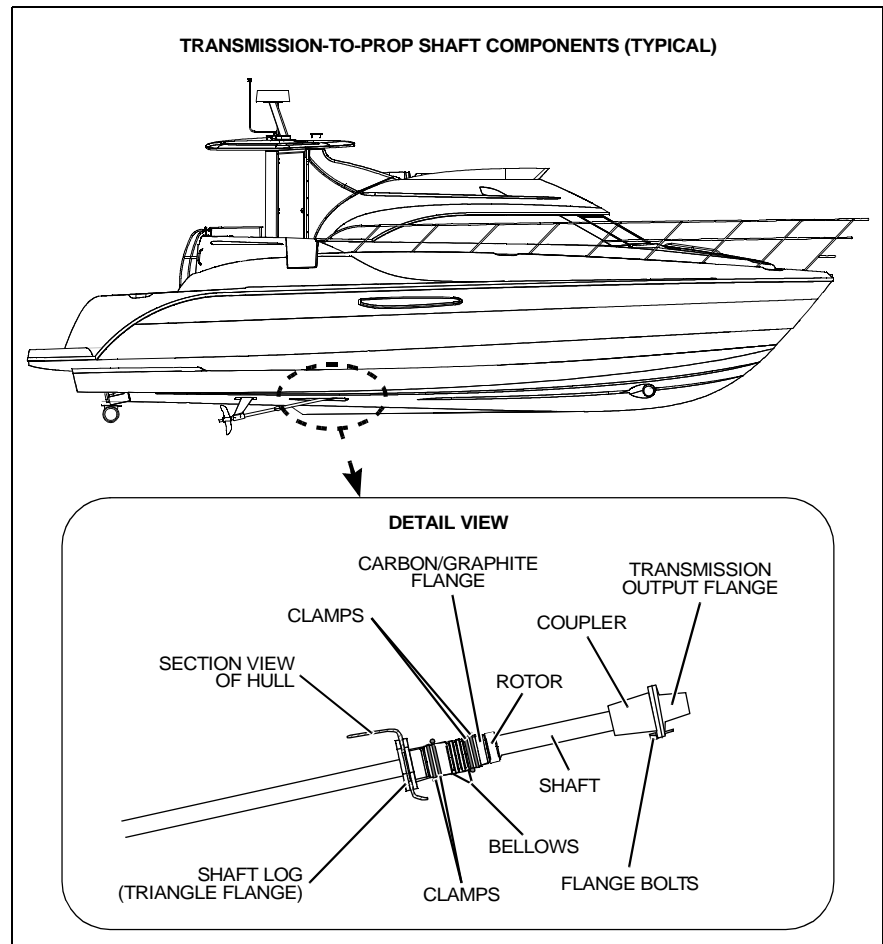

Chapter 4: Controls & Gauges

Steering

- This yacht features a hydraulic steering system.
- Check the fluid level in the hydraulic steering reservoir *every time* you use your yacht.
- Yacht steering is *not* self-centering.

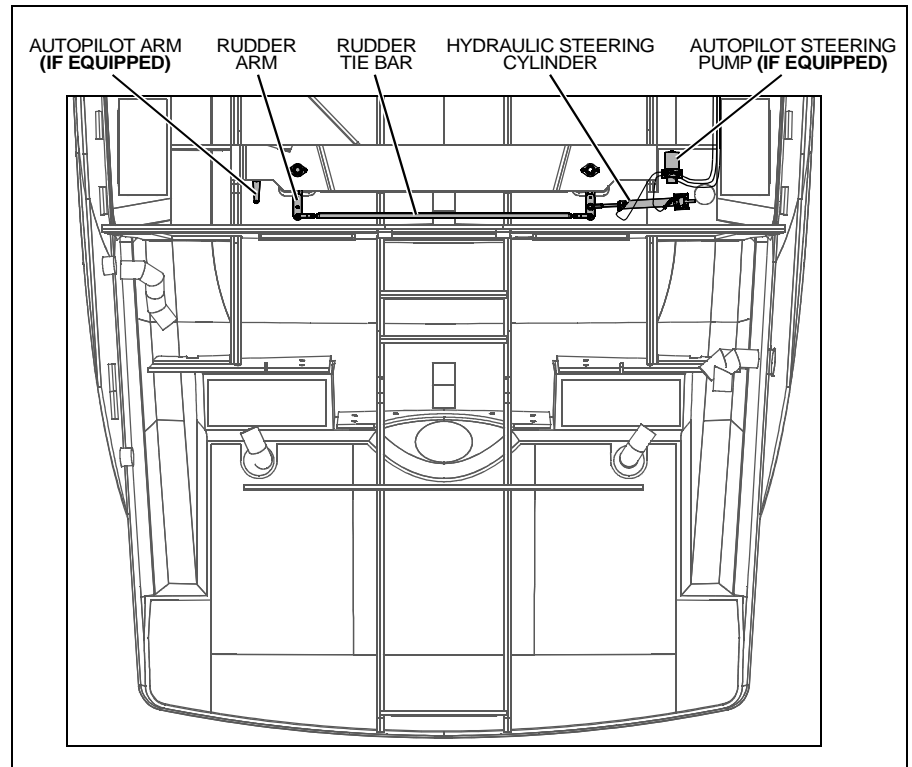

Rudder Stuffing Gland

- The rudder stuffing gland is part of the assembly where the rudders emerge from the bottom of the yacht.
- The shaft stuffing gland should *not* leak any water.
- If a leak develops, it can usually be stopped by tightening the packing gland nuts *slightly*.
- Do *not* over tighten the packing gland nuts.
- If stuffing gland leakage becomes excessive, packing replacement can be performed as follows:
 1. Remove the yacht from the water.
 2. Loosen the packing gland nuts and back the packing gland from the sleeve.
 3. Remove the old packing.
 4. Wrap new packing around the shaft.
 5. Cut the rings with a razor blade at an angle approximately 30 degrees to the long axis of the shaft.
 6. Stagger the ends of each ring around the shaft and insure that the rings are at the bottom in the sleeve.
 7. Tighten the packing gland nuts until resistance is felt.

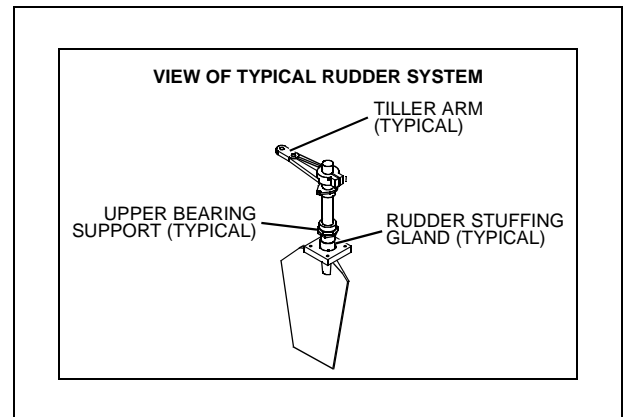

Autopilot (If Equipped)

 WARNING!
<ul style="list-style-type: none"> • NEVER leave the helm while the autopilot system is <i>On</i>! • A qualified operator <i>must</i> monitor the autopilot system at <i>all</i> times and keep a visual look-out for other marine traffic and other hazards.

NOTICE
<p>The autopilot system is only an aid to navigation. It's accuracy can be affected by:</p> <ul style="list-style-type: none"> • Equipment Failure or Defects • Environmental Conditions • Improper Handling Or Use

- Before using the autopilot system, read the autopilot instruction manual(s).
- The autopilot will aid you in maintaining the chosen course of your yacht.

Shift/Throttle Controls

 WARNING!
<p>LOSS OF CONTROL HAZARD!</p> <p>Improper maintenance of shift/throttle hardware may cause a sudden loss of control!</p>

Read *all* of the information about the shift/throttle controls in the shift/throttle controls' manual, the engine operation manual, and the *Cruiser & Yacht Owner's Manual Supplement*.

Engine Synchronization (If Equipped)

Follow the instructions in the synchronization section of the shift/throttle controls' manual.

Trim Tabs



WARNING!

LOSS OF CONTROL HAZARD!

Improper use of trim tabs will cause loss of control!

- Do *not* allow anyone unfamiliar with trim tabs to use them.
- Do *not* use trim tabs in a following sea as they will cause broaching or other unsafe handling characteristics.
- Do *not* use trim tabs to compensate for excessive unequal weight distribution.

- *Before* using the trim tabs read the trim tab operation manual.
- The trim tabs can be used to help keep your yacht level at cruising speeds.
- The trim tabs are controlled by two rocker switches at each helm.
- Once cruising speed is reached, the port or starboard trim switch may be used (one at a time) to level the yacht.
- Perform trim tab adjustment with several short touches to the switch rather than one long one.
- After each short touch allow several seconds for the hull to react.
- Periodically (at least once a year) check the fluid level in the trim tab hydraulic fluid reservoir and refill as necessary. For the location of the fluid reservoir see the Component Locations section of Chapter 2.

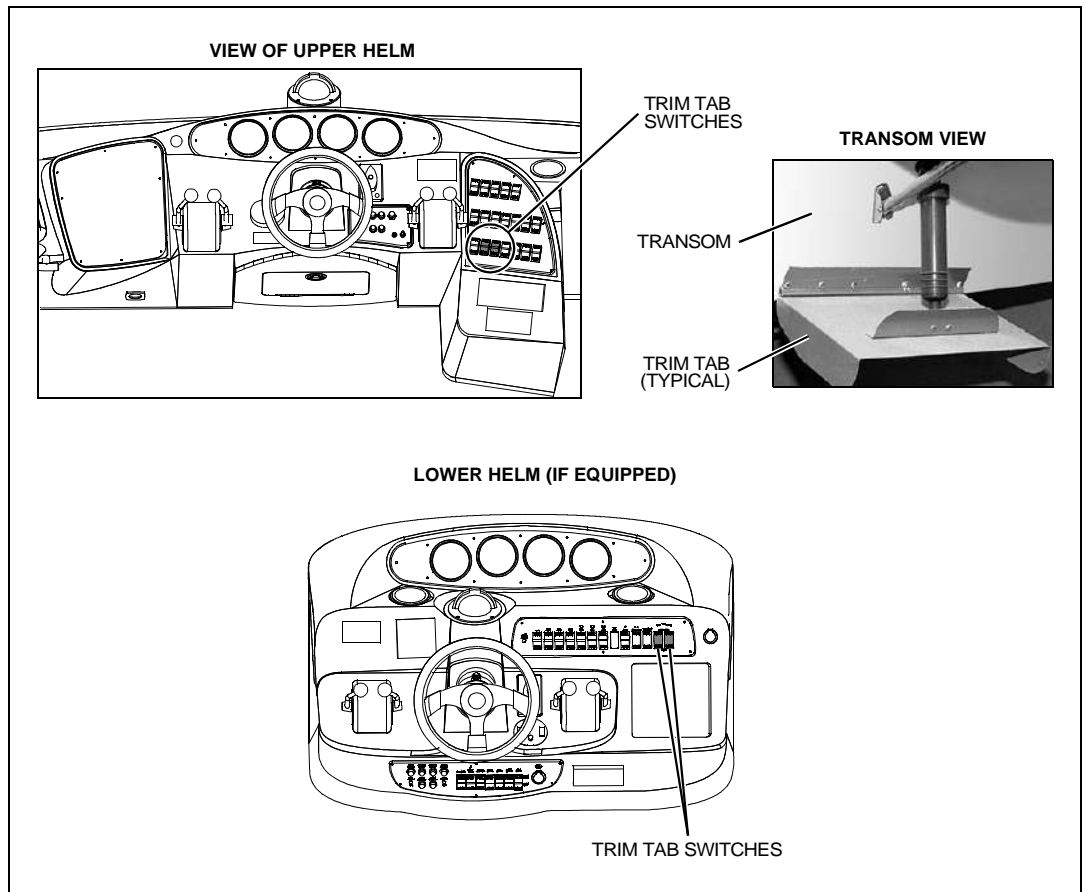

Dual Thruster System

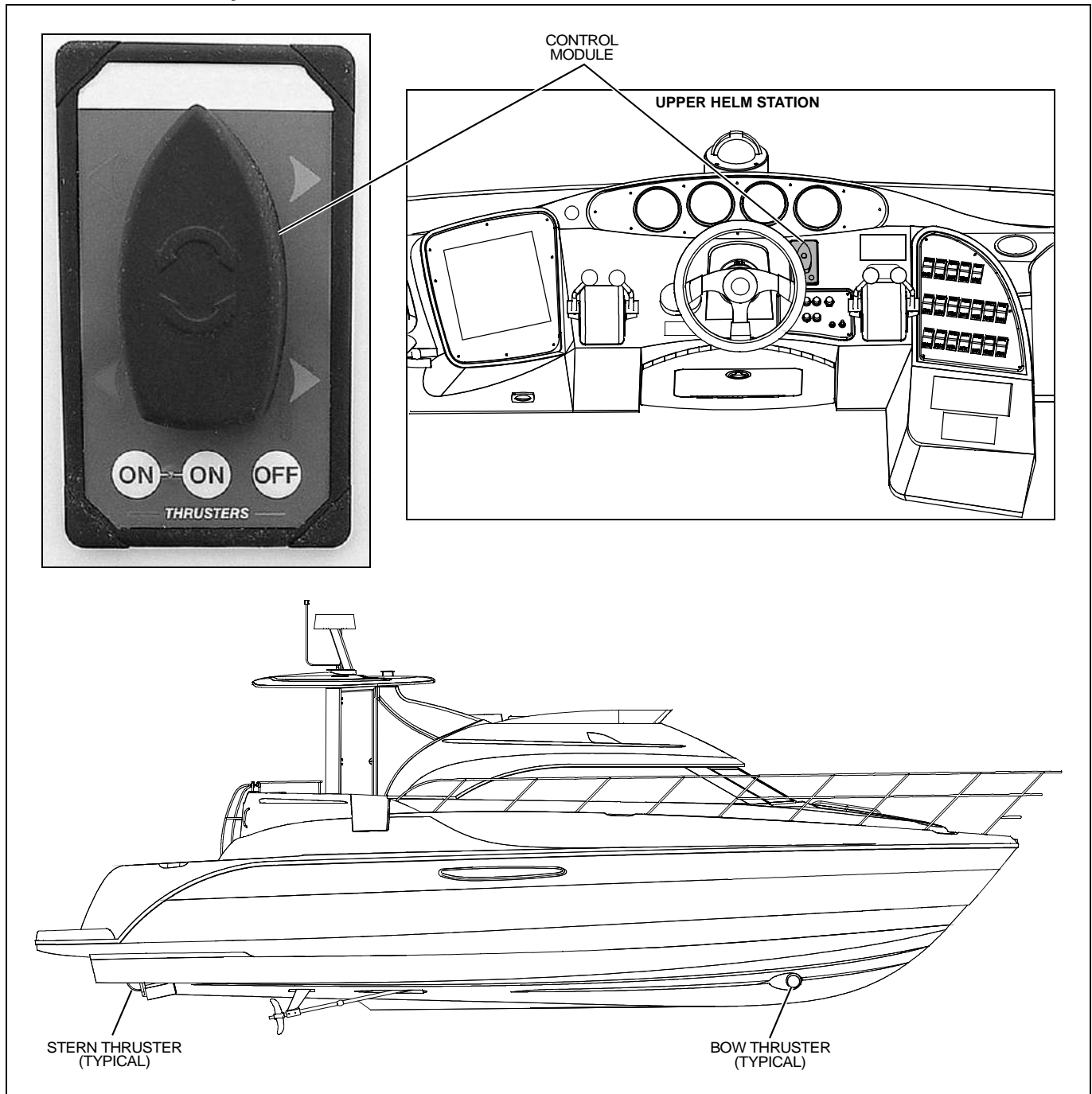

- This system features bow and stern thrusters.
- The thrusters can be controlled from either helm.
- During docking, the thrusters can assist you in maneuvering your yacht.
- Read the thruster's user manual *before* using the thruster system for the first time.
- Follow *all* user precautions carefully.

Gauges

Cleaning Gauges



CAUTION!

PRODUCT or PROPERTY DAMAGE HAZARD!

- Use only mild soap and water to clean the gauge lenses and bezels.
- Use of other cleaners, including common window cleaning solutions, may cause the lenses to crack.
- Lenses cracked in this manner will *NOT* be covered by our warranty.

Gauge Fogging

- Moisture may occasionally find its way into the gauges causing lens fogging.
- Turning *On* the gauge lights will help dry the lenses.
- Fogging will not harm the gauges.

Radio Transmission Interference

VHF or other radio transmissions may cause brief erratic readings on the tachometers. This will not damage these gauges or affect their accuracy when the radio is *not* transmitting.

Twin Engine Readings

It is normal for tachometers and other gauges to have slightly different readings between engines.

Fuel Gauge

It is normal for the pointers on your fuel gauges to bounce as fuel sloshes back and forth in the fuel tanks.

Chapter 5: Navigation & Communication Equipment

Read the manuals for *all* navigation & communication equipment *before* using these systems.

Compass

NOTICE

- **Compass accuracy can be affected by many factors.**
- **Have a qualified technician calibrate your compass.**
- **Make sure the technician gives you a deviation card which shows the corrections to apply in navigational calculations.**
- **Keep a copy of the deviation card at each helm.**

Depth Finder



WARNING!

- **Do *NOT* use the depth finder as a navigational aid to prevent collision, grounding, yacht damage or personal injury.**
- **When the yacht is moving, submerged objects will *not* be seen until they are already under the yacht.**
- **Bottom depths may change too quickly to allow time for the yacht to react.**
- **If you suspect shallow water or submerged objects, run the yacht at very slow speeds.**

VHF Radio (If Equipped)

- Your yacht may include a VHF (Very High Frequency) radio.
- The VHF radio can be used to access weather reports, summon assistance or contact other vessels as permitted by the FCC (Federal Communications Commission).
- Contact the FCC for licensing, rules and regulations concerning VHF radio usage.

Radar (If Equipped)



WARNING!

- Radar is meant to help the navigator, *not* replace him/her.
- The operator is responsible for keeping a visual look-out for possible collision situations.
- No single navigation aid (including this radar) should be relied upon as the only method for navigating your yacht.

NOTICE

The Radar system is only an aid to navigation. It's accuracy can be affected by:

- Equipment Failure or Defects
- Environmental Conditions
- Improper Handling Or Use

- The marine radar system gives you a complete and accurate 360° radar view of other vessels, buoys, and landfall surrounding your vessel.
- To turn this system *On*, the 'Bridge Main' breaker on the battery switch panel *must* be switched *On*. Then power up the radar/GPS Chart Plotter.

Global Positioning System (GPS) (If Equipped)



WARNING!

- The GPS system should *not* be relied upon as the *only* aid to navigation.
- A qualified operator *must* monitor the GPS system at *all* times and keep a look-out for other marine traffic and possible collision situations.

NOTICE

The GPS system is only an aid to navigation. It's accuracy can be affected by:

- Equipment Failure or Defects
- Environmental Conditions
- Improper Handling Or Use

- GPS receivers provide reliable and accurate position data, anywhere in the world.
- To turn this system on, the 'Bridge Main' breaker *must* be switched *On*, then power up the GPS Chart Plotter.
- If equipped with an autopilot, the autopilot switch on the dash must be turned *On* to power up the GPS sensor. See the Autopilot System in Chapter 4 of this manual.

Chapter 6: Plumbing

Bilge Pumps

NOTICE

Discharge of oil, oil waste or fuel into navigable waters is prohibited by law. Violators are subject to legal action by the local authorities.

- Your yacht is equipped with several bilge pumps for pumping water out of the bilge.
- The bilge pumps are controlled by automatic float switches (autofloat switches) and/or switches at the helm.
- The bilge pumps are wired directly to the battery.
- Unless the battery is dead, the pumps should work even when the boat is unattended.

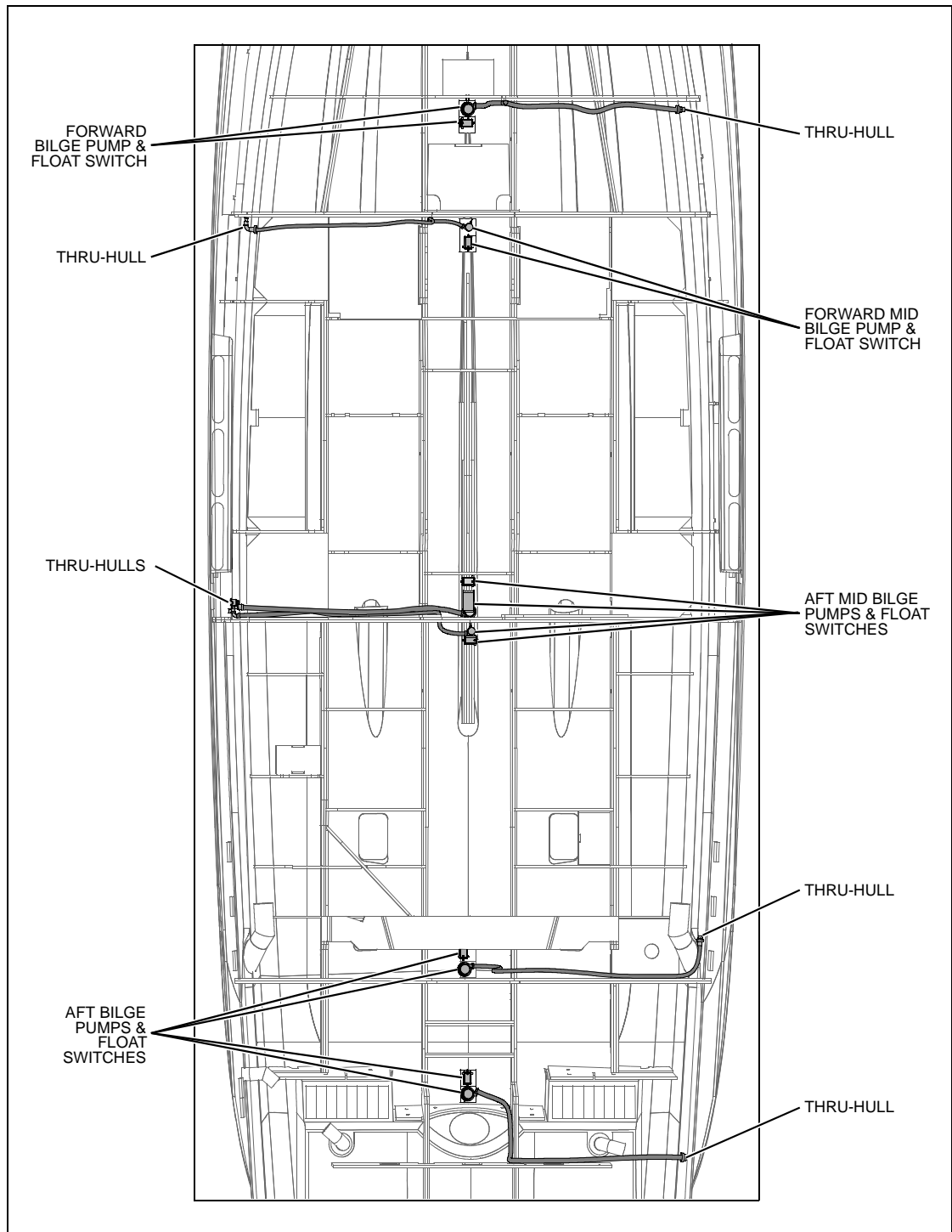

Bilge Pump Testing

- The bilge pumps are vital to the safety of your yacht.
- Test the bilge pumps often to make sure they are working properly.

To test each bilge pump:

1. One at a time, turn **On** the bilge pump switches at the helm.
2. Make sure that water in the bilge is pumped overboard.

If there is water in the bilge and a pump motor is running, but **not** pumping, inspect the discharge hose for a kink or collapsed area.

If the discharge hose looks okay, check the bilge pump and strainer for clogging debris.

Checking the bilge pump and strainer for clogging debris:

1. With your thumb and forefinger squeeze the holding tabs on each side of the strainer.
2. Lift out the bilge pump.
3. Check the pump and strainer and clear any debris.

Reinstalling the bilge pump:

1. Align the tabs on the strainer with the slots on the pump.
2. Press down firmly until the tabs click into place.
3. Make sure the bilge pump is locked into place.

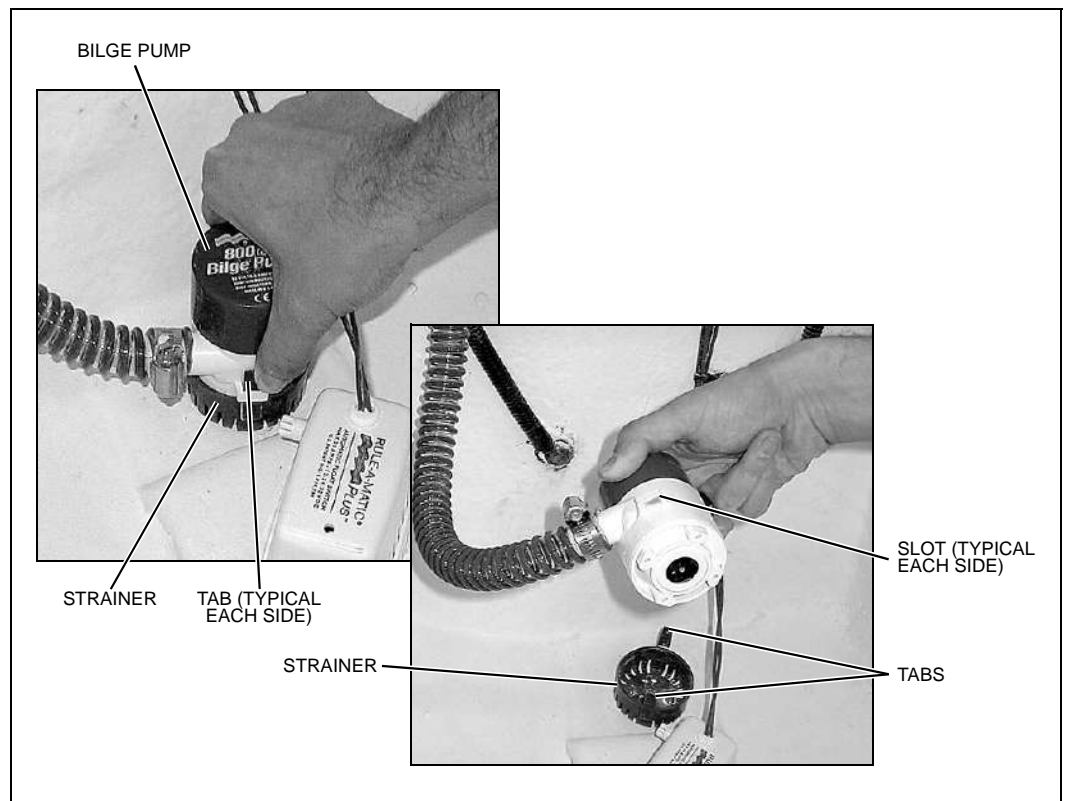

Autofloat Switches

- Each automatic bilge pump features an autofloat switch.
- The autofloat switch turns the pump **On** when water rises above a preset level.
- Each autofloat switch is normally located next to the bilge pump it controls.
- The autofloat switches should be tested often.

Testing the autofloat switches

1. Twist either of the white plastic knobs one quarter turn to lift the float and turn **On** the bilge pump.
2. If the pump does **not** turn **On**, check the inline fuse.
3. If the fuse is good but the switch doesn't work, it may indicate a bad switch or possibly a low battery.

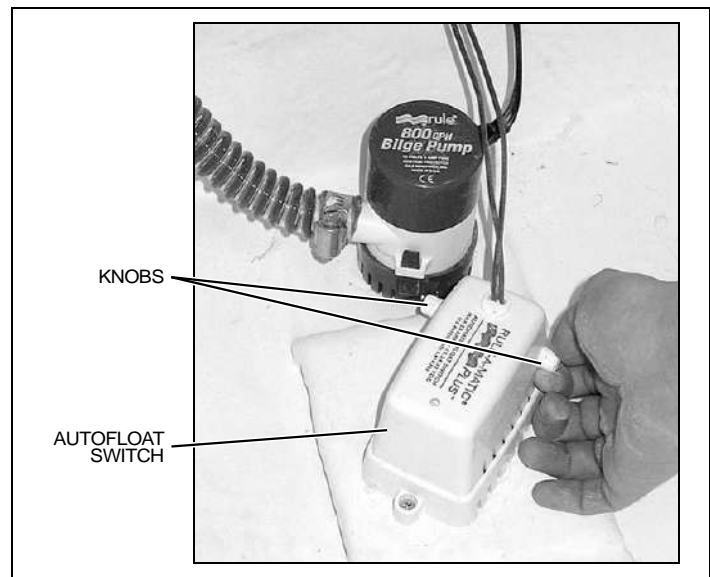

Seawater Systems

Seacocks



CAUTION

SYSTEM DAMAGE HAZARD!

- *Before* using a seawater intake system, make sure that the system's seacock is in the *Open* position *before* the system is started and keep the seacock *Open* until the system is shut *Off*.
- *Close* the seacocks whenever the systems will *NOT* be used for long periods of time.

A seacock is a thru-hull valve, that may be opened to let in water or discharge liquids such as waste from the holding tank. Seacocks are typically used on your yacht in the following seawater intake or liquid discharge systems:

- Engines
- Generator (if equipped)
- Air conditioning system (if equipped)
- Marine head system

Before using any of these systems, make sure that the system's seacock is *Open* and remains *Open* until the system is shut *Off*.

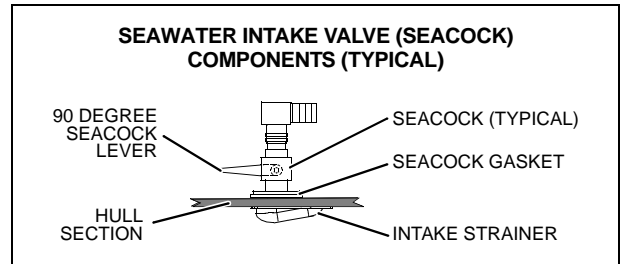

Seawater Strainers

- Seawater strainers are used in water intake systems to filter incoming seawater.
- A seawater strainer is located near each system's seacock.
- Check the strainers for leaks and/or debris *every time* you use your yacht.
- If debris is found, clean the seawater strainer.

Cleaning a seawater strainer:



CAUTION

FLOODING HAZARD!

- The seacock that sends seawater to the strainer must be *CLOSED* before disassembling the seawater strainer to prevent the yacht from taking on water through the seawater strainer assembly.
- Keep the seacock *CLOSED* until the seawater strainer is completely reassembled.

SYSTEM DAMAGE HAZARD!

- *After* reassembling the seawater strainer, make sure that the seacock valve is *OPEN* *before* using the component/system.

1. Make sure the component/system (generator, air conditioning system, etc.) that the strainer is connected to is turned *Off*.
2. *Close* the seacock that sends seawater to the strainer you are about to clean. The seacock must remain *Closed* until the strainer is completely reassembled.
3. Take apart the seawater strainer.
4. Remove the debris.
5. Flush the strainer with water.
6. Reassemble the seawater strainer.
7. *Open* the seacock and check for leaks around the strainer. If no leaks are found, you may use the component or system.

Seawater Washdown System (If Equipped)

 **CAUTION**

FLOODING & SWAMPING HAZARD!

NEVER leave your yacht unattended while using the "seawater washdown" feature. Any leak or break in the system may allow large amounts of water to accumulate in the bilge that could cause swamping of the batteries and engines or even sinking of the yacht.

- **Always** make sure the seawater intake seacock is **Open before** turning the seawater washdown system **On**.
- This system can be pressurized by turning **On** the seawater washdown pump.
- See the *Locations* section of this *Owner's Manual* for the location of the seawater washdown pump circuit breaker.

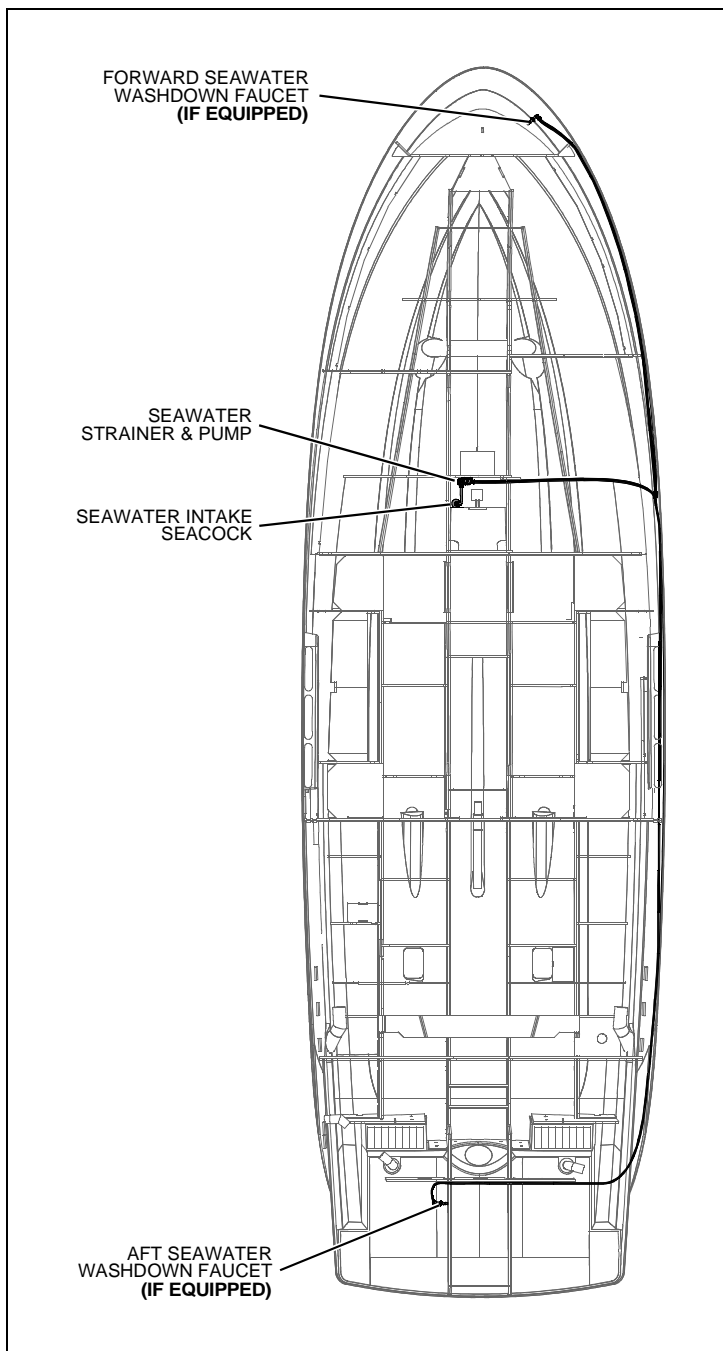

Freshwater System



WARNING!

- **Only** use safe drinking (potable) water in your yacht's freshwater system.
- **Only** use an FDA approved, white 'drinking water safe' hose to fill the freshwater tank or to connect to city water.
- **NEVER** use a common garden hose for drinking water.

- Read the *Freshwater System* section in the *Cruiser & Yacht Owner's Manual Supplement*.
- Your yacht is equipped with a pressure type (demand) freshwater (potable) system.
- This system can be pressurized by turning **On** the freshwater pump switch or by connecting to city water.
- See the *Locations* section of this *Owner's Manual* for the locations of the freshwater pump switch and the city water inlet.
- Since the freshwater pump requires DC power, the battery switch **must** also be turned **On** for the pump to work.
- **Never** leave the yacht unattended while using the 'city water' feature.
- Turn **Off** the freshwater pump switch when the yacht is not in use or when the freshwater tank is empty.
- Inspect and clean the freshwater filter often (located on the freshwater pump).
- If your yacht is to be left unattended for a long period of time, pump the freshwater tank dry to prevent stored water from becoming stagnant and distasteful.
- If the freshwater system needs to be disinfected, ask your dealer about the treatments available.

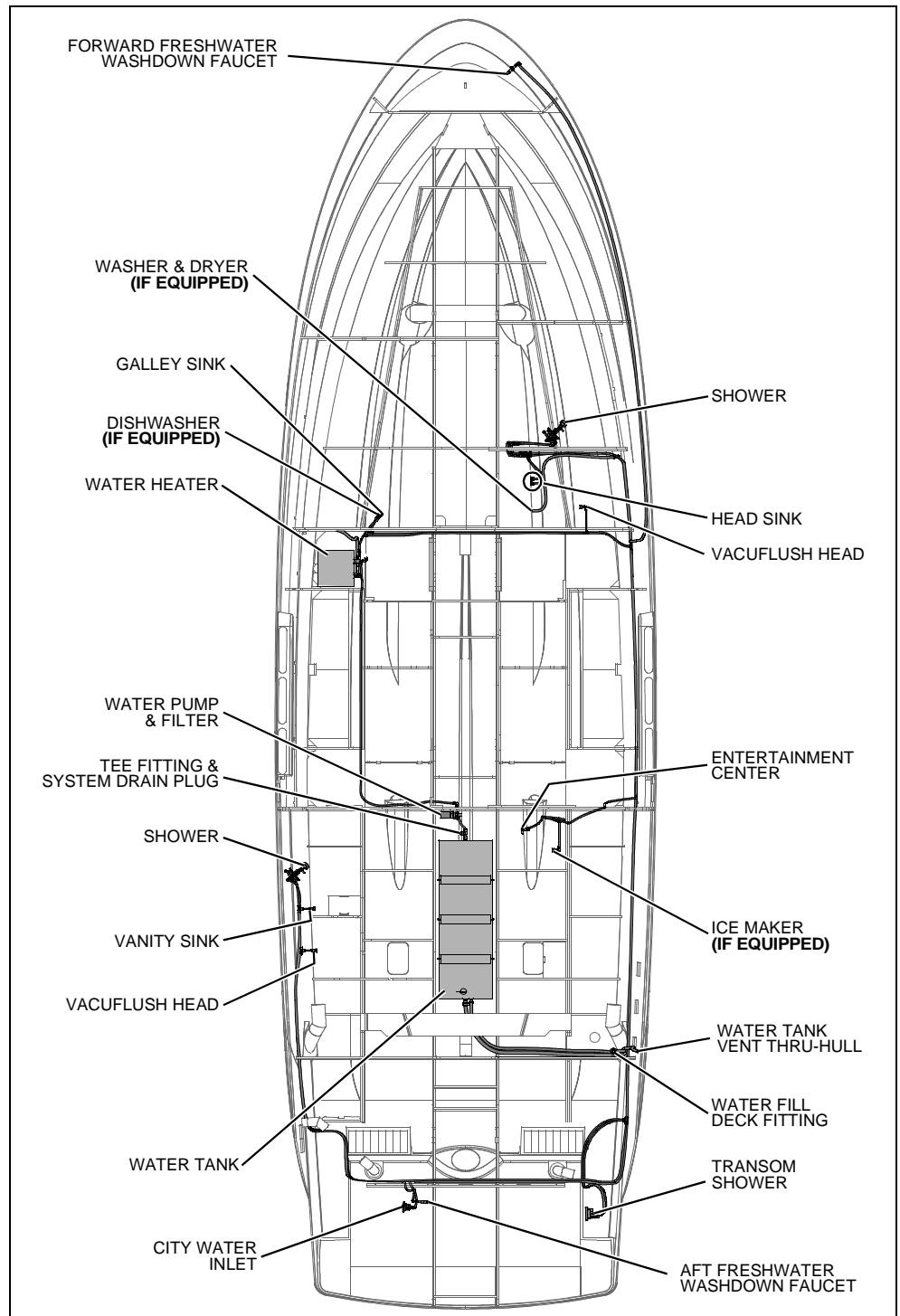

Freshwater System Winterization

⚠ CAUTION

WATER SYSTEM DAMAGE HAZARD!

NEVER blow compressed air through the water system when *all* of the faucets are *Closed*.

1. Turn **On** the freshwater pump switch.
2. **Open all** of the faucets and showers and let the freshwater system drain completely.
3. Turn **Off** the freshwater pump switch.

All remaining water **must** be removed from the water lines. There are two ways to remove the remaining water from the lines:

- Compressed Air
- Gravity Draining

Compressed Air

You **must** have an air compressor with an air hose and an air nozzle.

1. Remove the water line from the outlet side of the freshwater pump (opposite side from filter).
2. **Open** the faucet that is furthest away from the freshwater pump.
3. Place the air nozzle against the end of the just removed water line and blow air through the system.
4. When the water stops coming out of the **Open** faucet, stop the air and **Close** the faucet.
5. One at a time, repeat this process on **all** of the faucets and showers.

Gravity Draining

1. **Open all** faucets and showers.
2. Remove the drain plug from the tee fitting on the freshwater tank.
3. When the water has stopped draining from the freshwater tank, replace the drain plug.

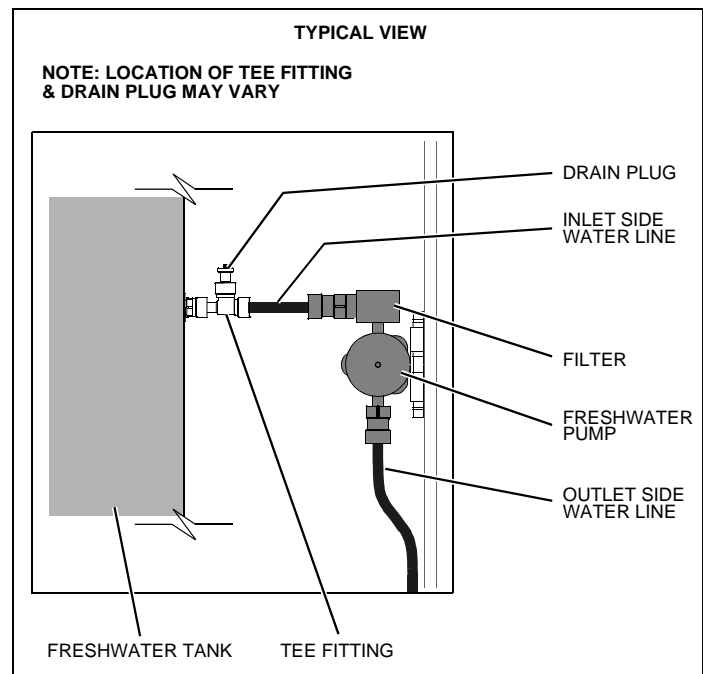

Transom Shower

- Read the manufacturer's instructions *before* using the transom shower for the first time.
- To use the transom shower, the yacht *must* be connected to a dockside freshwater supply, or the freshwater pump switch *must* be turned *On*.

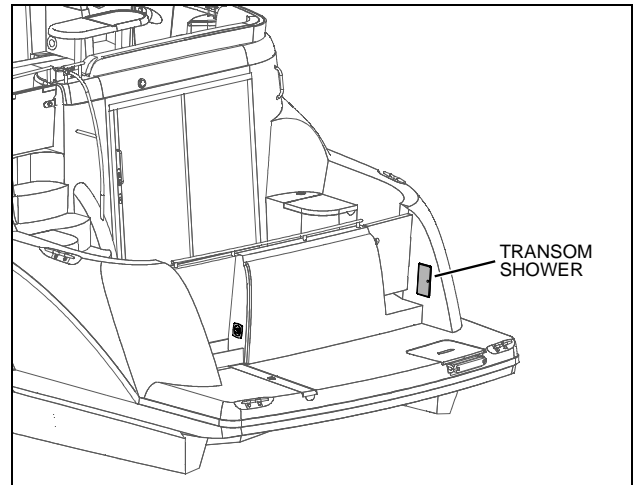

City Water Inlet

CAUTION

FLOODING & SWAMPING HAZARD!

- *NEVER* leave the yacht unattended while using the 'city water' feature.
- Any leak or break in the system may allow large amounts of water to accumulate in the bilge that could cause swamping of the batteries and engines or even sinking of the yacht.

- Read the *City Water Hookup* portion of the *Freshwater System* section in the *Cruiser & Yacht Owner's Manual Supplement*.
- When the yacht is connected to a dockside freshwater supply, the freshwater system is pressurized.
- The freshwater pump's DC breaker *must* be *Off*.

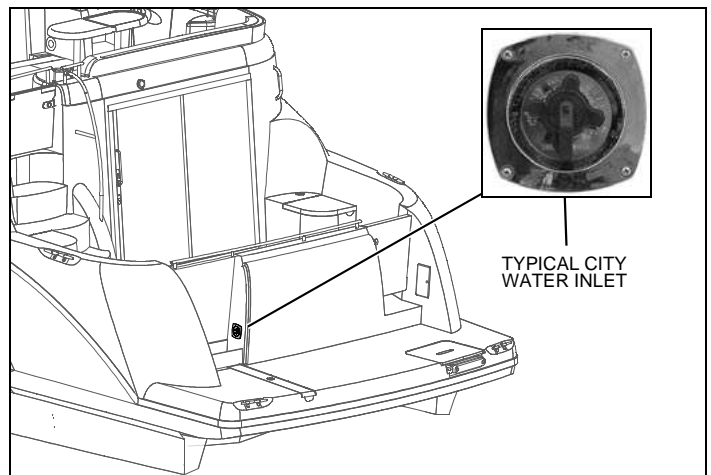

Water Heater

⚠ WARNING!

⚠ SCALDING HAZARD!
Water heated by the water heater can be hot enough to scald the skin.

⚠ CAUTION!

WATER HEATER DAMAGE HAZARD!

- Do **NOT** turn **On** the water heater electrical circuit on the AC panel until the water heater tank is **COMPLETELY** filled with water.
- Even momentary operation in a dry tank *will* damage the heating elements.
- Warranty replacements will **NOT** be made on elements damaged in this manner.
- The tank is full if water flows from the tap when the hot water is turned **On** in the galley.
- The water heater should be drained and the power turned **Off** when the possibility of freezing exists.

NOTICE

If your yacht is connected to shore power or generator power, but the water heater is *NOT* working:

- Make sure the water heater circuit breaker on the AC panel is switched **On**.
- If the circuit breaker on the AC panel is **On**, but the water heater is still **NOT** working: Ask your dealer how to check the 'push to reset' circuit breaker located on the water heater.

- Read the water heater instruction manual and heed the warnings above.
- The water heater is connected to the 110-volt, AC power system.
- Turn **On** the water heater breaker on the AC panel to heat the water.

Winterizing the Water Heater

1. Turn **Off** the water heater breaker.
 2. Disconnect the hose (A) attached to the pressure relief valve (B).
 3. If there is any water in this hose, drain it into the bilge or into a bucket.
 4. **Open** the pressure relief valve (B).
 5. **Open** the drain valve (C).
- Leave the pressure relief and drain valves **Open** until you fit out the yacht after storage.



Drain Systems

Deck Drains

- Water on the deck is drained overboard through the deck drains.
- Keep the deck drains free of debris.

Gray Water Drains

The galley sink is above the waterline and is gravity drained overboard.

Sump Pump Drain System

- The showers and head sinks drain into sump pump boxes.
- Each sump pump box has a float switch.
- When water rises to a preset level the float switch turns **On** a sump pump, to pump the water overboard

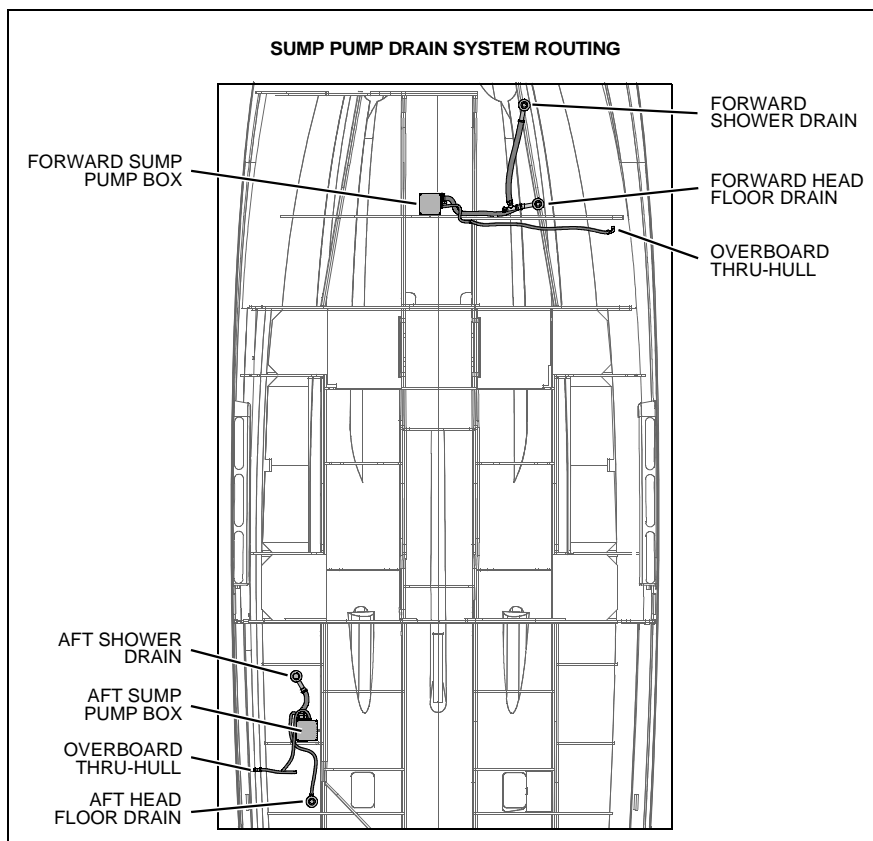

Sump Box Cleaning

Periodically clean each sump box, filter, and pump as follows:

1. Remove the cover screws (A) and the cover (B).
2. Remove any debris from the box and the filter.
3. Clean the sump pump as outlined in the Bilge Pump section of this manual.

Sump System Winterization

Drain the sump pump systems in the winter months when **not** in use.

1. Disconnect and drain **all** lines to the unit.
2. Remove the screws from the mounting feet (C).
3. Turn the box upside down to remove the rest of the water.
4. Reinstall the screws in the mounting feet and reconnect the system.

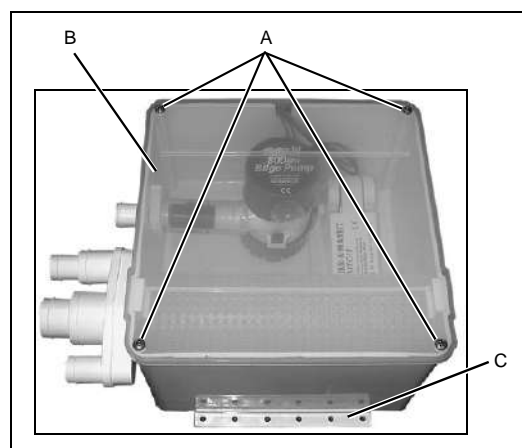

Marine Head & Holding Tank

NOTICE

Check with local authorities for regulations regarding the legal use of marine head systems.

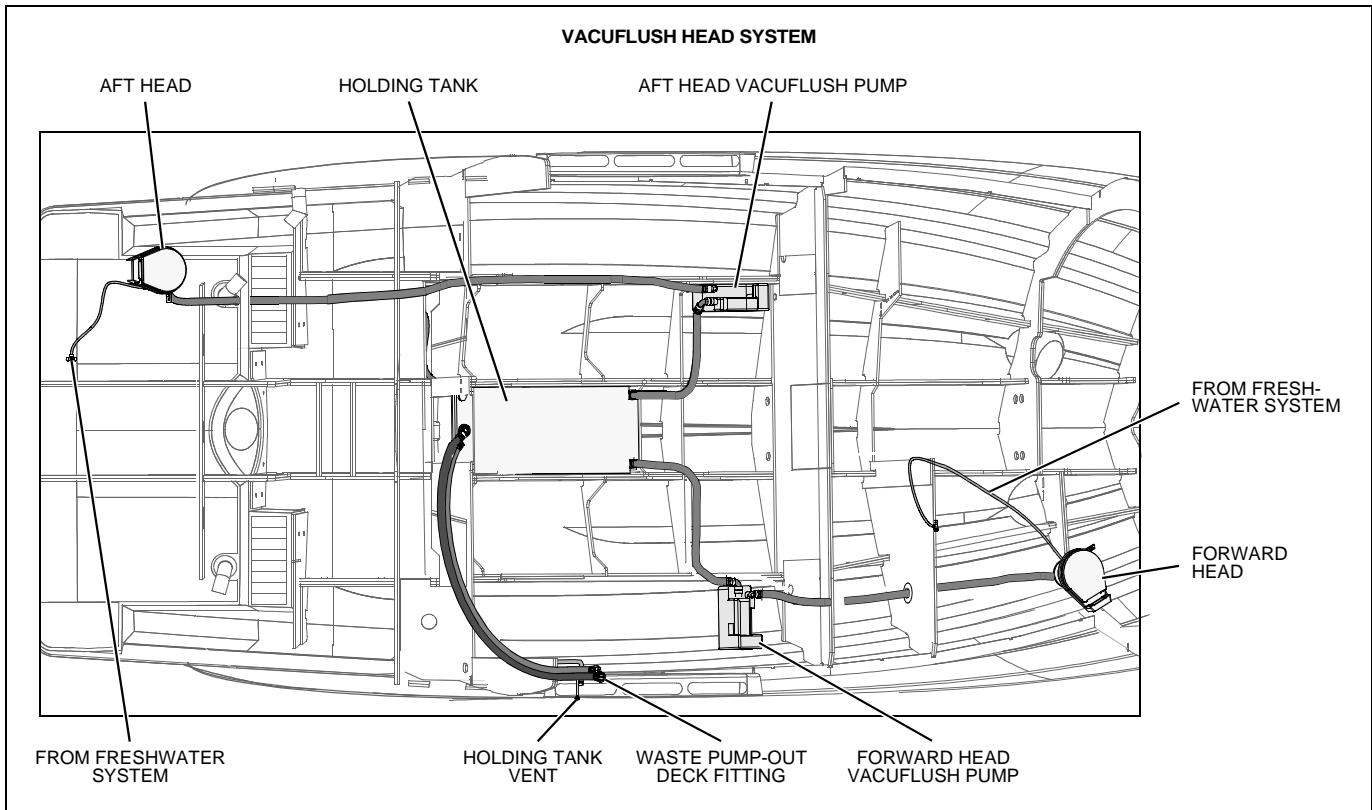

VacuFlush Head System

- Read the VacuFlush operation and maintenance manual.
- The VacuFlush head system uses freshwater from the freshwater tank and a vacuum pump to flush waste from the toilet into the holding tank.
- The holding tank is plumbed to a waste fitting on the deck for dockside pump-out.
- To check the content level of the holding tank, look at the monitoring gauge. For the location of the holding tank monitoring gauge, see the *Locations* section of this *Owner's Manual*.
- Empty the holding tank at every opportunity.
- For winterizing instructions, refer to the VacuFlush head, operation and maintenance manual.

Macerator (If Equipped)

To use the macerator to pump waste directly into the water (where regulations permit):

1. ***Open*** the overboard discharge seacock.
2. Press both macerator switches at the same time to run the pump.
3. Stop running the macerator as soon as the waste holding tank is empty.
4. ***Close*** the overboard discharge seacock when you are done pumping.

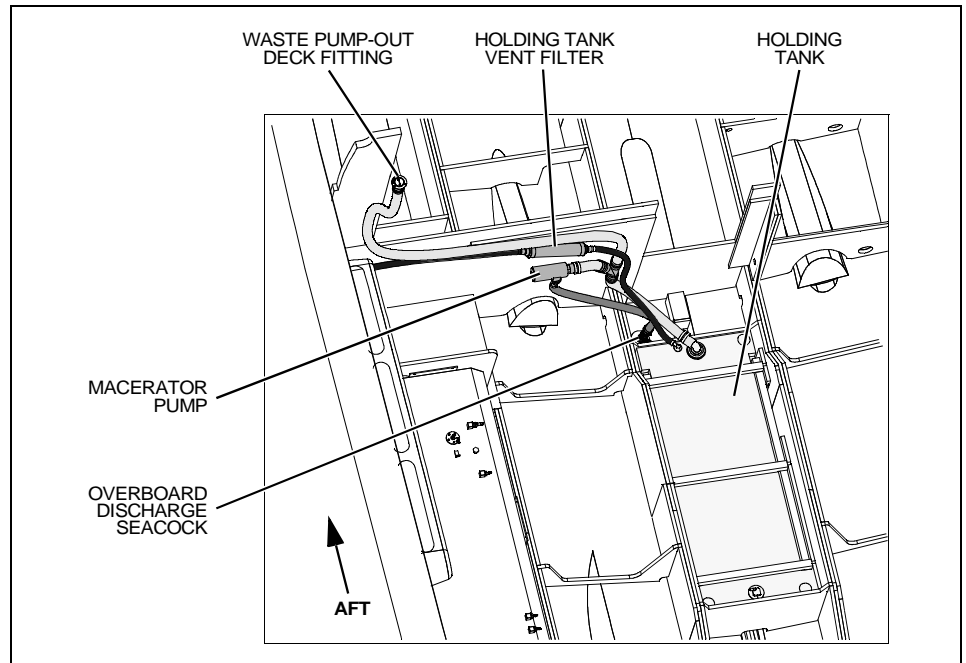

Chapter 7: Deck Equipment

Cleats

 WARNING!
<p>PERSONAL INJURY and /or PRODUCT or PROPERTY DAMAGE HAZARD!</p> <p>NEVER lift the yacht using the cleats.</p>

Carefully read the section on towing in the *Cruiser & Yacht Owner's Manual Supplement* before towing anything behind your yacht or having your yacht towed by another vessel.

Windlass

 DANGER!
<p>PERSONAL SAFETY HAZARD!</p> <ul style="list-style-type: none"> • ALWAYS secure the anchor and other loose objects <i>before</i> getting underway. • The anchor, and other items that are not properly secured, can come loose when the yacht is moving and cause personal injury or death.

 CAUTION
<p>PRODUCT DAMAGE HAZARD!</p> <p>Do NOT pull the yacht to the anchor using the windlass or continue to run the windlass if it has stalled or is overloaded.</p>

- Read and follow the manufacturer's instruction manual *before* using the anchor windlass for the first time.
- The windlass can be controlled from a switch at the helm or from the deck foot switches.
- Make sure that the windlass breaker is turned **On before** using the anchor windlass.
- To raise the anchor, use engine power (**not** the windlass) to move the yacht to, and directly above, the anchor.
- Dislodge the anchor from the bottom by pulling it straight up with the windlass.
- Make sure the anchor is secured *before* getting underway.

Canvas



CAUTION

Take down and securely stow the canvas top, side curtains and back cover before transporting your yacht by road.

1. Insert the end eyes of the main bow (A) into the deck hinges near the aft ends of the windscreen and secure with the pins.
 2. Pull the secondary bows (B) forward and insert the end eyes of the forward braces (C) into the forward deck hinges and secure with the pins.
 3. Insert the end eyes of the aft braces (D) into the deck hinges on the hard top.
- The jaw slides should *not* need to be adjusted.
 - However, if you think the jaw slides need to be adjusted, obtain the measurements from your selling dealer.

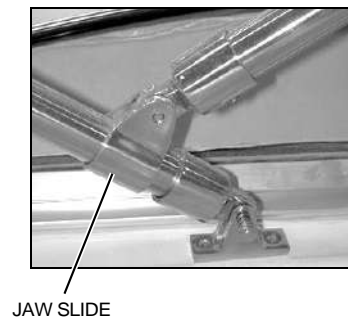
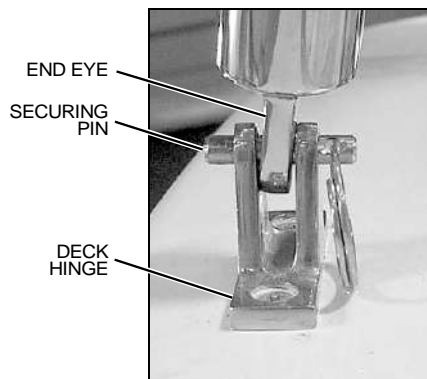
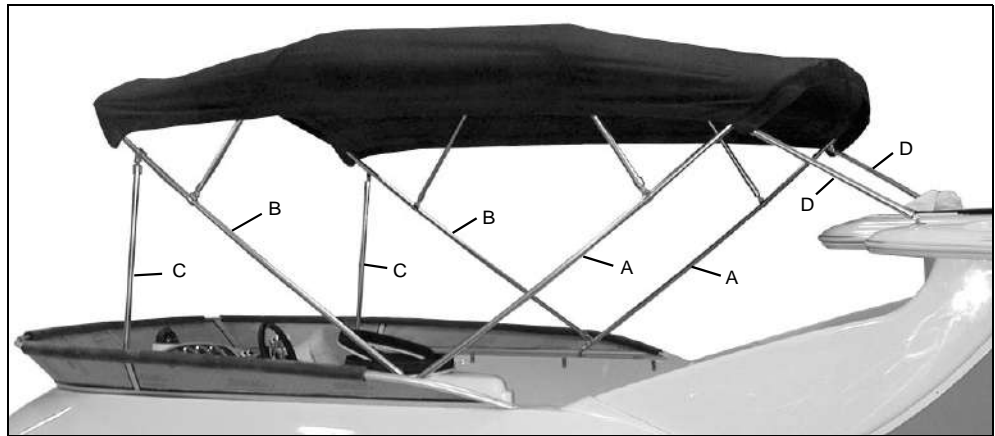

Canvas Care (see also, 'Clear Vinyl Care' on next page)

- After each use, especially in saltwater, rinse the canvas with cold freshwater.
- Before stowing, let the canvas air dry completely.
- The canvas can be rolled or folded for stowage.

Cleaning Canvas

 CAUTION
<p>NEVER use detergents when washing the canvas. Detergents can destroy the water repellency, and mildew/UV resistant finish of your canvas.</p>

Regularly clean the canvas to prevent dirt, pollen, and etc. from embedding in the fabric. Generally, it is easiest to wash the canvas while it is installed on the yacht.

1. Use a soft-bristled brush to remove all dust and loose dirt.
2. Hose down the canvas with freshwater.
3. Gently wash the canvas with a solution of lukewarm water (no more than 100 F) and non-detergent soap, such as Lux or Ivory Flakes.
4. Rinse thoroughly to remove the soap.
5. Before stowing, let the canvas air dry completely.

Stubborn Stains

 CAUTION
<ul style="list-style-type: none"> • Soaking in bleach solutions may remove the waterproof finish of the fabric and may also decrease the life of the polyester thread used in the canvas. • If necessary, a water repellent treatment should be re-applied to your canvas. Ask your dealer about the treatments available for your yacht's canvas.

Some stubborn stains may resist normal washing and you can try the following methods. However, these methods may remove the waterproof finish of the fabric and may also decrease the life of the polyester thread used in the canvas. Reapply a water repellent treatment as necessary.

Method 1

1. Add 1/8 cup (2 oz.) of **non-chlorine** bleach to one gallon of water and mix thoroughly.
2. Thoroughly wet the canvas and then gently scrub the stained area with the weak bleach solution.
3. Rinse with cold water to remove all of the solution.

Method 2

1. Add 1/2 cup (4 oz.) of **non-chlorine** bleach and 1/2 cup (4 oz.) Ivory Flakes to one gallon of water and mix thoroughly.
2. Soak the canvas in this solution for about 20 minutes.
3. Rinse with cold water to remove all of the solution.

Clear Vinyl Care



CAUTION

- **NEVER** store the clear vinyl pieces wet, as this will cause a milky film to develop.
- **NEVER** fold or crease the clear vinyl pieces as cracking will occur.
- Clear vinyl is **NOT** intended for use when the yacht is in storage or being moored.
- Clear vinyl does **NOT** hold up well against ultraviolet rays.
- Under direct sunlight conditions, do **NOT** let the clear vinyl touch the framework. The framework radiates heat and can burn the clear vinyl.

- After each use, especially in saltwater, rinse the clear vinyl with cold freshwater.
- **Before** stowing, the clear vinyl must be completely dry. Air drying is best, but you can also carefully dry the vinyl with a chamois or soft cotton cloth.
- The clear vinyl can be rolled or laid out flat for stowage.
- **Never** fold or crease the clear vinyl parts as cracking will occur.

Cleaning Clear Vinyl

Regularly clean the clear vinyl to prevent dirt, pollen, and etc. from marring the surface. Generally, it is easiest to clean the clear vinyl while it is installed on the yacht.

1. Hose down the clear vinyl with freshwater.
2. Using a soft cotton cloth (**paper towels are abrasive and should never be used on clear vinyl**), gently wash the clear vinyl with soap and water.
3. Rinse thoroughly to remove the soap.
4. **Before** stowing, the clear vinyl must be completely dry. Air drying is best, but you can also carefully dry the vinyl with a chamois or soft cotton cloth.

NEVER FOLD OR CREASE CLEAR VINYL!
FOLDING OR OTHERWISE CREASING
CLEAR VINYL WILL CAUSE DAMAGE
SUCH AS CRACKING TO OCCUR



AFTER CLEAR VINYL PARTS
HAVE COMPLETELY AIR DRIED
THEY CAN BE ROLLED OR SIMPLY
LAID FLAT FOR STOWAGE

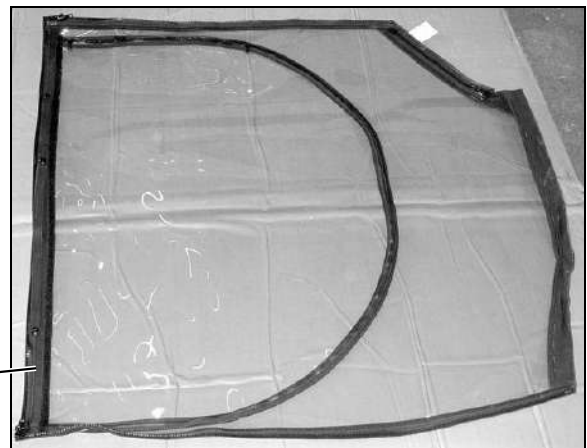

Ask your dealer about products available to keep the clear vinyl polished and looking new.

Chapter 8: Appliances & Entertainment Systems

NOTICE

Always keep an approved ABC-type fire extinguisher in galley area.

All appliances and entertainment systems installed on your yacht come with their own manuals. These manuals contain detailed instructions and important safeguards. Read these manuals *before* using your yacht's appliances and entertainment systems.



- Make sure the AC breaker is turned *On* for the appliance you wish to use.

Refrigerator

Your yacht features a 110-volt AC/12-volt DC refrigerator. The refrigerator runs on 12-volt DC power unless 110-volt AC power is being supplied by shore power or generator power *and* the AC refrigerator breaker is *On*.

Electric Stove (If Equipped)

 **WARNING!**





BURN/SCALDING and/or FIRE HAZARD!

- Read the stove's instruction manual *before* using.
- *Always* keep an approved ABC-type fire extinguisher in galley area.
- Do *NOT* use the stove while underway.
- Any non-cooking devices on or near your stove during use are potential fire hazards!
- Do *NOT* touch burners, grates or nearby surfaces as they may be hot even when they are dark in color. Areas near burners and grates may become hot enough to cause burns.
- During and after use, do *NOT* touch or let clothing or other flammable material come in contact with heated units or areas near the units (burner tops, main frame sides and back, sea rails and pot holders) until they have had sufficient time to cool.

Range/Oven (If Equipped)

 **WARNING!**





BURN HAZARD!

- Do *NOT* touch stove burners, grates or areas near the stove units as they may be hot even when they are dark in color. Areas near burners and grates may become hot enough to cause burns.
- During and after use, do *NOT* touch or let clothing or other flammable material come in contact with heated units or areas near the units (burner tops, main frame sides and back, sea rails and pot holders) until they have had sufficient time to cool.

Coffeemaker (If Equipped)

**WARNING!**

**BURN/SCALDING HAZARD!**

- Read the coffeemaker's instruction manual *before* using.
- Do *NOT* use the coffeemaker while underway.
- Water heated by the coffeemaker can be hot enough to scald the skin.

Audio & Visual Equipment

NOTICE

AM radio reception may be impaired anytime the engine is running.

Dockside Television & Telephone Inlet

Plug a dockside source into the TV/telephone inlet if you want to watch cable TV or use a telephone.

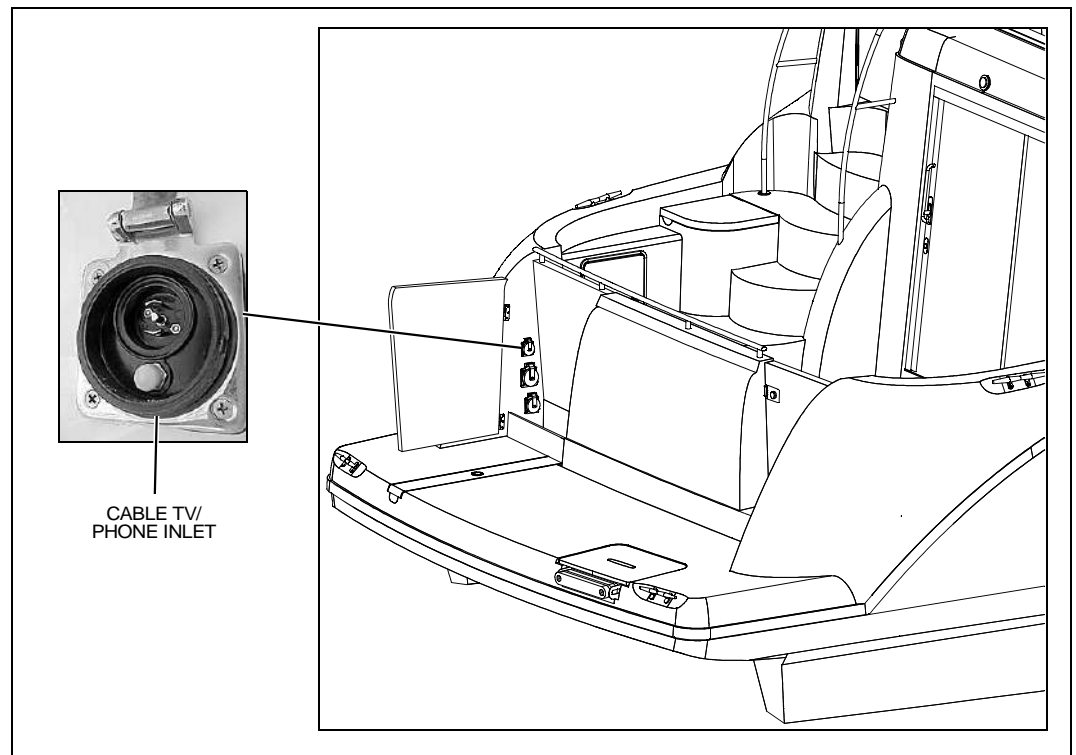

Chapter 9: Lights

Care and Maintenance

All of the lights installed on your yacht are of top quality, but you should be aware that failure may periodically occur for a variety of reasons:

1. There may be a blown fuse - *replace the fuse.*
2. The bulb may be burned out - *carry spare bulbs for replacement.*
3. A wire may be damaged or may have come loose - *repair as required.*
4. The bulb base may be corroded - *clean the base and coat it with non-conductive electrical lubricant.*

Interior & Exterior Lights

 CAUTION
<ul style="list-style-type: none"> • Be conservative in the use of battery power. • Prolonged use of cabin interior lights (overnight) will result in a drained battery.

- The lights are powered by the yacht's 12-volt DC system.
- The battery switch must be in the **On** position for the lights to work.

Navigation Lights

 CAUTION!
<p>Avoid the storage of gear where it would block navigation lights from view.</p>

Read the navigation light section of the *Cruiser & Yacht Owner's Manual Supplement*.

Spotlight

Read the spotlight's operating instructions *before* using the spotlight.

Chapter 10: Heating & Air Conditioning

Air Conditioning System (If Equipped)

! DANGER!

CARBON MONOXIDE POISONING HAZARD!

Dangerous carbon monoxide gas (CO) can be brought into the yacht through the air conditioning system.



The diagram shows a triangular warning symbol with a skull and crossbones inside. Below the symbol, the letters 'CO' are written in a large, bold font. Underneath 'CO', the word 'DANGER' is written in a smaller, bold font, and at the bottom, 'CARBON MONOXIDE' is written in an even smaller font.

! CAUTION

SYSTEM DAMAGE HAZARD!

The air conditioning system's seawater intake and discharge seacocks *must be Opened before* turning *On* the air conditioner and *must stay Open* during use.

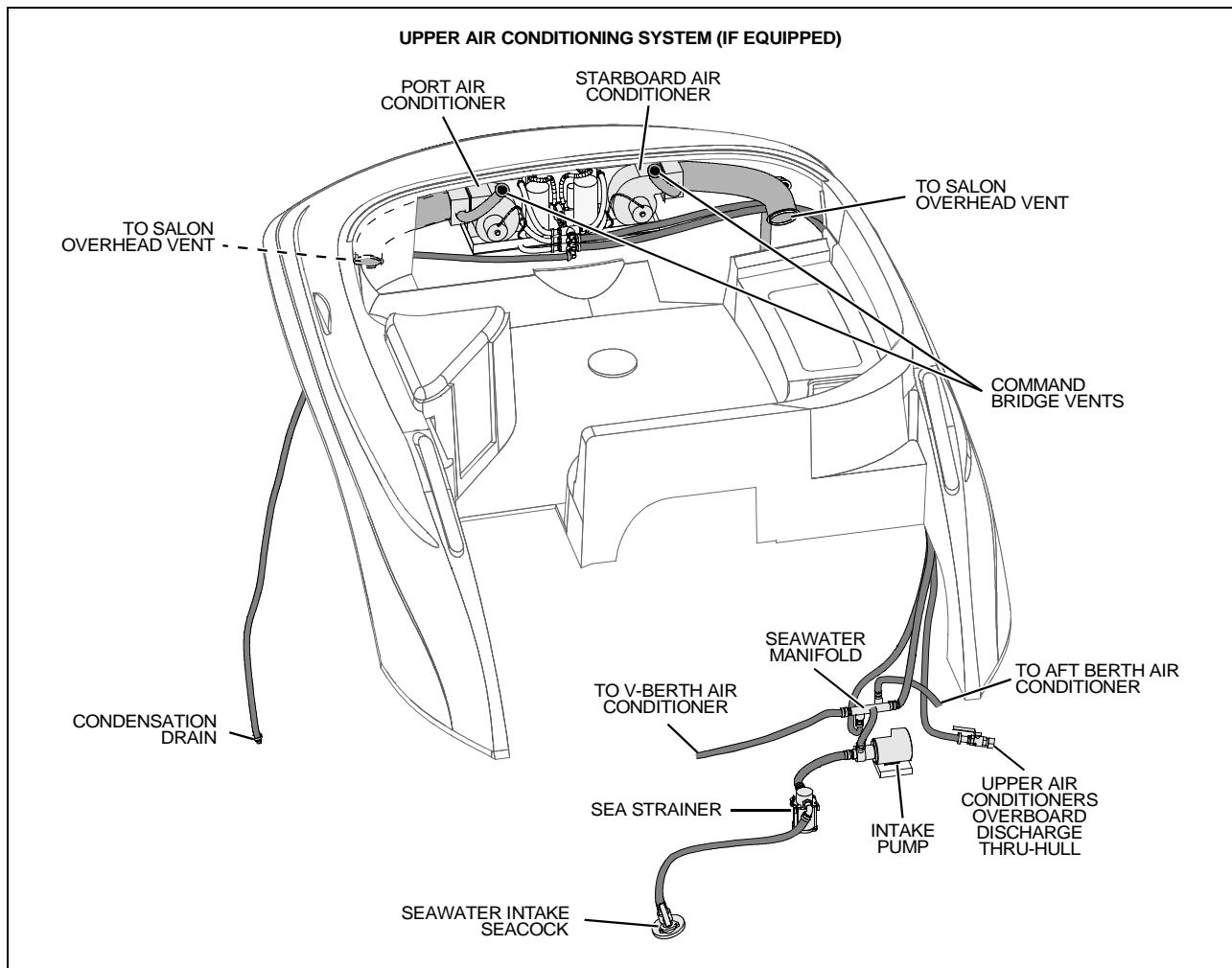

- Read the air conditioner manual *before* using the air conditioning system.
- *Before* using the air conditioning system, make sure the breakers on the AC main distribution panel are turned *On* and that the system's seawater intake and discharge seacocks are *Open*.
- The seacock *must* remain *Open* while the air conditioner is in use.
- Check the seawater strainer for debris *before* each use of the air conditioning system.
- If the strainer needs to be cleaned out; follow the directions in the *Seawater Systems* section of this *Manual*.

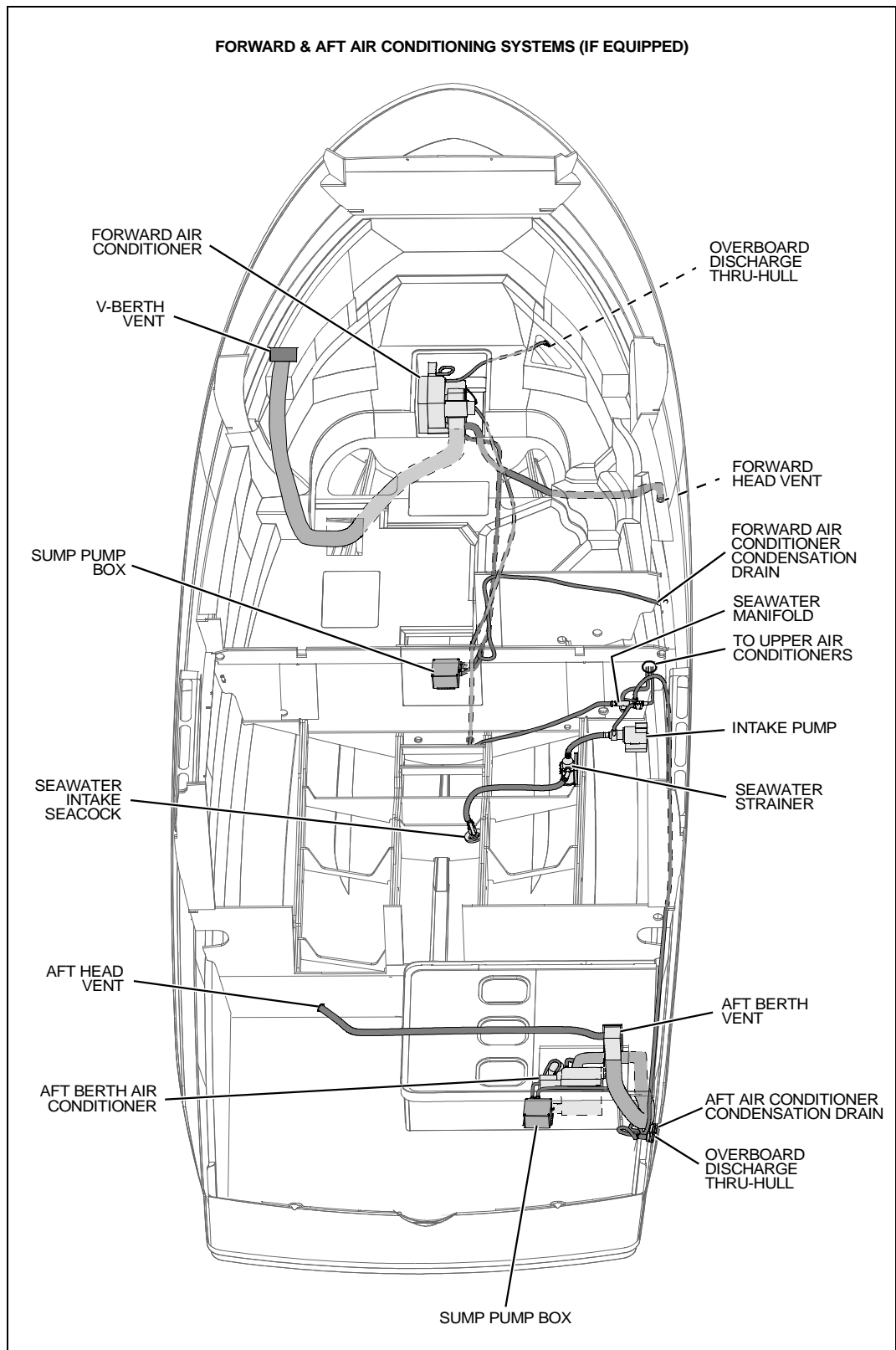

Heat Exchanger Cabin Heat (If Equipped)

The heat exchanger cabin heater runs directly off the starboard engine.

Before using the heat exchanger cabin heater:

1. Read the manufacturer's instruction manual.
 2. Make sure the circulation loop shut-off valve is **Open**.
 3. Turn **On** the circuit breaker for the heater fan.
- If the heat exchanger circulation loop is **Open** and the starboard engine is running, the heater will radiate heat even if the heater fan is turned **Off**.
 - **All** circulation to the heater can be shut **Off** by **Closing** the circulation loop shut-off valve.

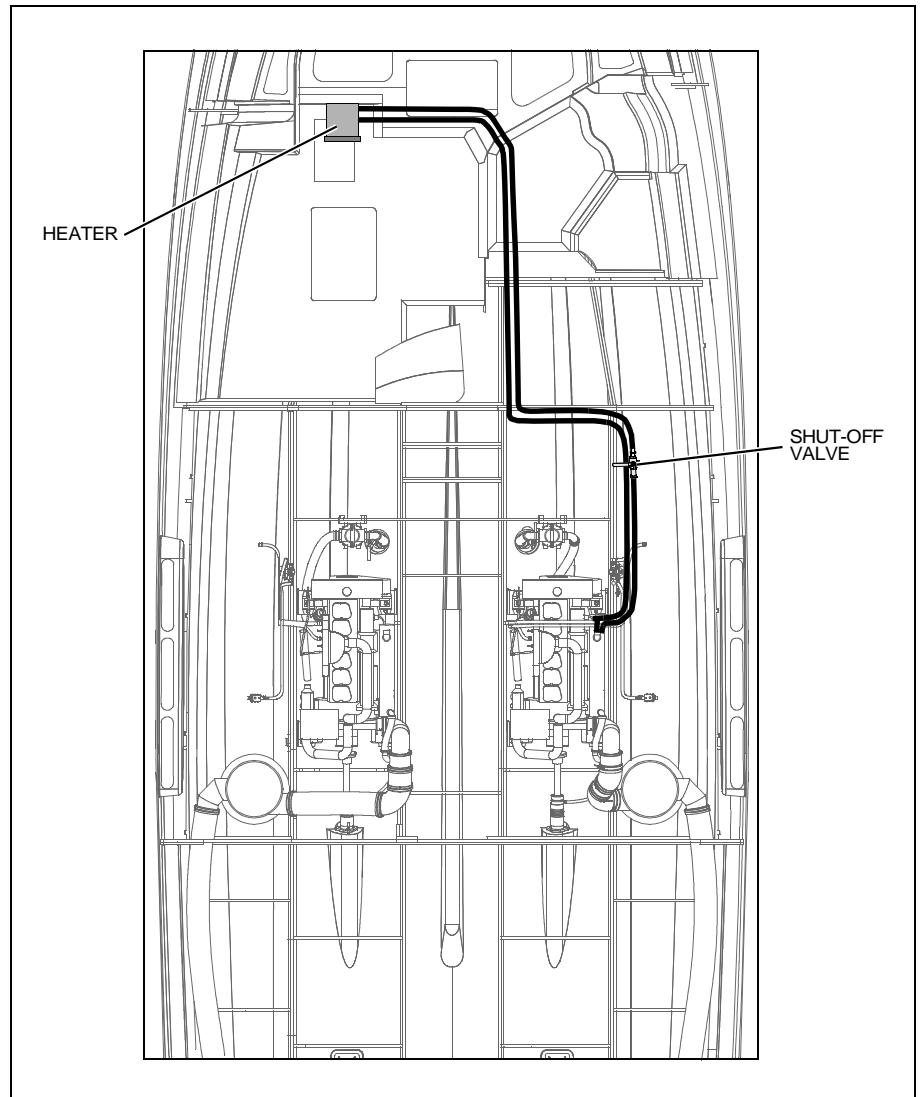





Electric Heaters (If Equipped)

Your yacht may feature electric cabin heaters. Operating instructions for this system can be found in the manufacturer's instruction manual.

- **Before** using the electric heaters, make sure the breakers on the AC panel are turned **On**.

Chapter 11: Electrical System





 **DANGER!**

EXTREME FIRE, SHOCK & EXPLOSION HAZARD!

- To minimize the risks of fire and explosion, *NEVER* install knife switches or other arcing devices in the fuel compartments.
- *NEVER* substitute automotive parts for marine parts. Electrical, ignition and fuel system parts were designed and manufactured to comply with rules and regulations that minimize risks of fire and explosion.
- Do *NOT* modify the electrical systems or relevant drawings.
- Allow only qualified marine electricians to install batteries and/or perform electrical system maintenance.
- Make sure that all battery switches are turned *OFF* before performing any work in the engine spaces.

 **WARNING!**

FIRE & EXPLOSION HAZARD!

- Fuel fumes are heavier than air and will collect in the bilge areas where they can be accidentally ignited.
- Visually and by smell (sniff test), check the engine, generator, and fuel compartments for fumes or accumulation of fuel.
- *ALWAYS* run the bilge blowers for at least four minutes prior to engine or generator starting, electrical system maintenance, or the activation of electrical devices.
- Minimize the danger of fire and explosion by not exposing the batteries to open flame or sparks. *NEVER* smoke anywhere near the batteries.

 **CAUTION**



SHOCK & ELECTRICAL SYSTEM DAMAGE HAZARD!

When the engines are running, *NEVER* turn *Off* the main battery switches or disconnect the battery cables. Doing either could cause damage to your yacht's engines and/or electrical system components.

NOTICE

Electrical connections are prone to corrosion. To reduce corrosion caused electrical problems, keep all electrical connections clean and apply a spray-on protectant that is designed to protect connections from corrosion.

12-Volt DC System

Batteries

The batteries supply electricity for lights, accessories, and engine starting.

The Electrical section of Chapter 8, in the *Cruiser & Yacht Owner's Manual Supplement*, provides battery, care and maintenance instructions.

Battery Switches

⚠ CAUTION

SHOCK & ELECTRICAL SYSTEM DAMAGE HAZARD!

When the engines are running, *NEVER* turn *Off* the main battery switches or disconnect the battery cables. Doing either could cause damage to your yacht's engines and/or electrical system components.

NOTICE

Make sure your selling dealer fully explains how to use the battery switches.

- A separate battery switch is provided for each battery (or battery bank).
- 'Standby Loads', such as the automatic bilge pumps, and the stereo memory, are not affected by the battery switches since they are wired directly to the batteries.
- Turn the battery switches to the *Off* position whenever the yacht will be unoccupied for long periods of time.

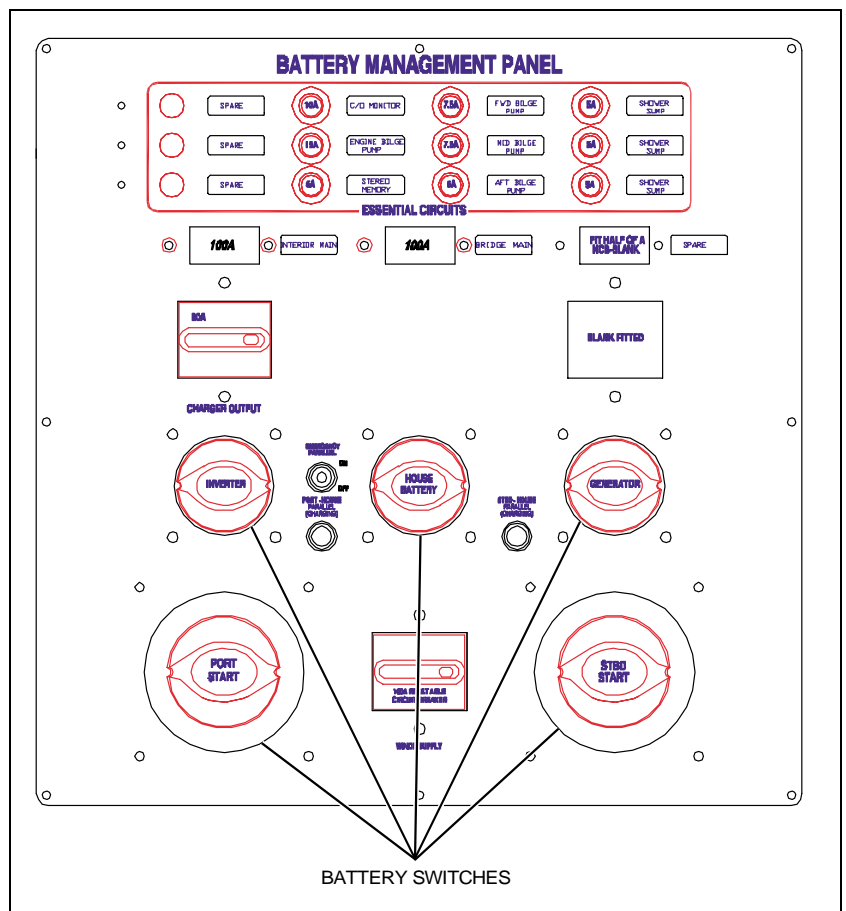

Emergency Battery Parallel Switch

- If an engine will *not* start because of a dead battery, the battery parallel switch allows you to use the other batteries for engine starting.
- A battery parallel switch is provided on the battery management panel and at each helm (see illustrations on right).
- Emergency parallel switch instructions are provided on the VSR Charging Module Information Sheet.

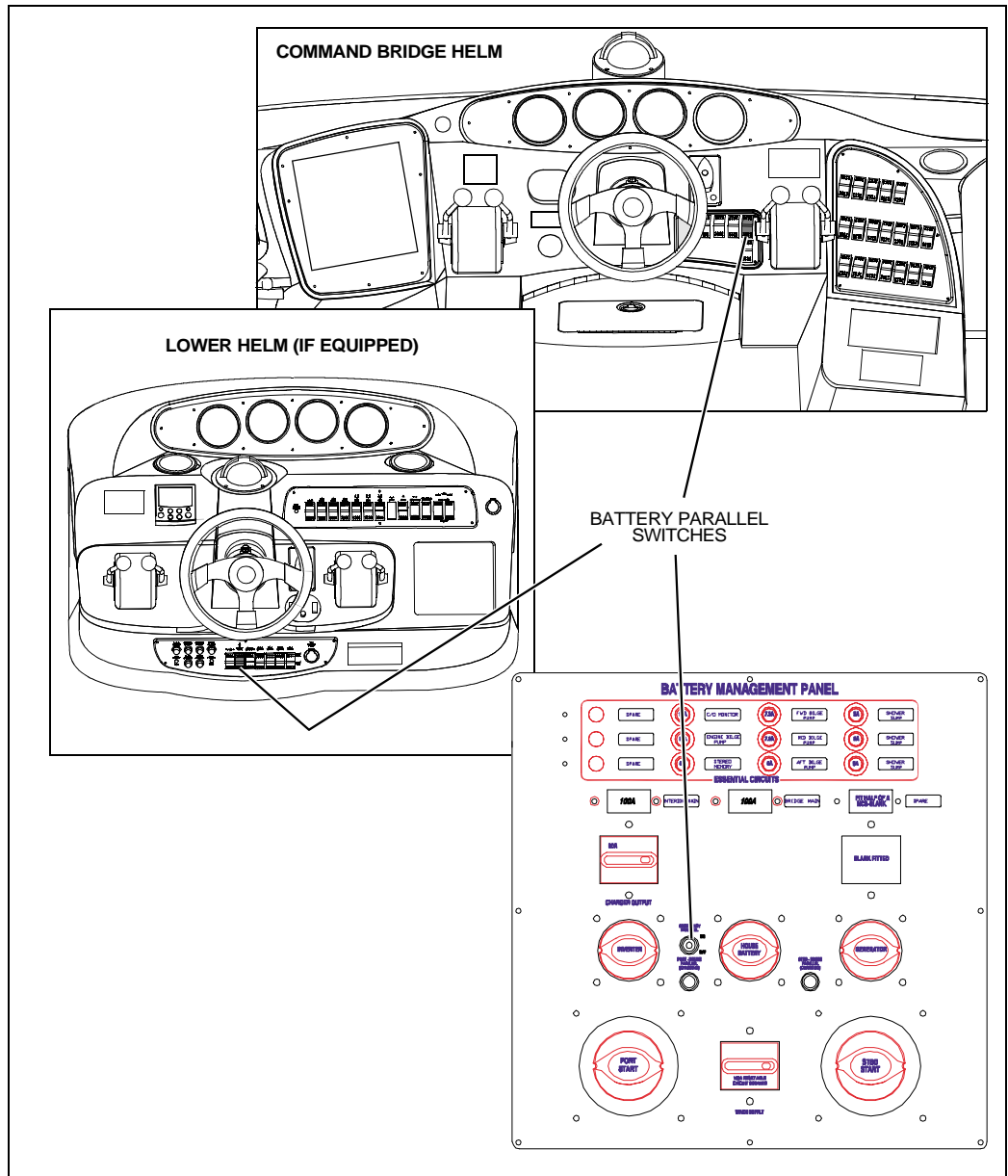

Fuses and Circuit Breakers

The fuses and circuit breakers for the engines and main accessory power are on the following panels (the locations of these panels are provided in Chapter 2 of this *Owner's Manual*):

- DC main distribution panel.
- DC push-to-reset breaker panel.
- Battery management panel.
- Some equipment may have secondary fuse protection at the unit, behind the battery management panel, or at the batteries.

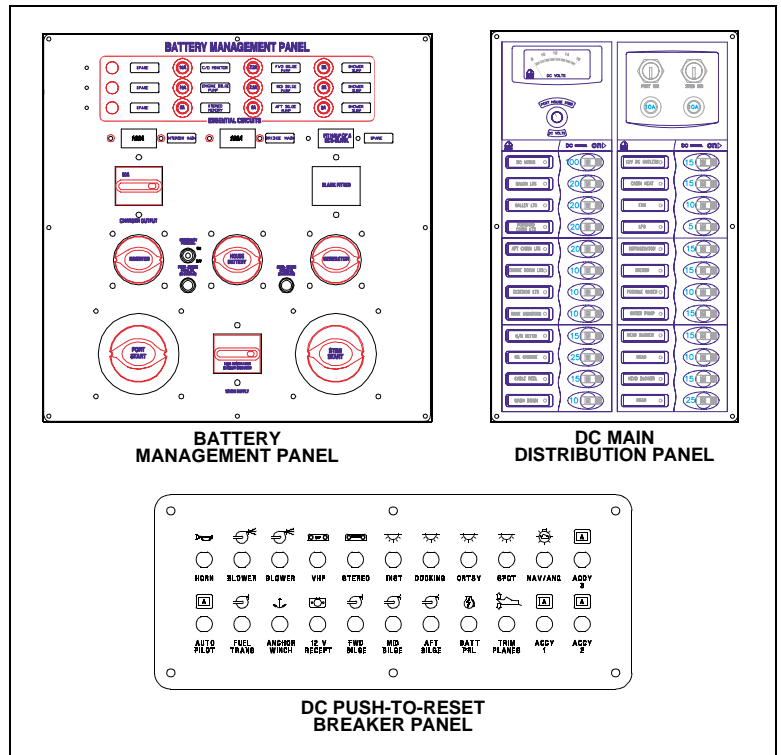

12-Volt Accessory Outlet(s)



CAUTION

Do *NOT* use the 12-volt accessory outlet with a cigarette or cigar lighter. High temperatures may melt the outlet.

- Your boat features one or more 12-volt accessory outlets.
- The outlet can be used with any 12-volt device which draws 15 amps or less.
- The 12-volt accessory outlet is protected by a 15 amp circuit breaker on the main circuit breaker panel.

Alternators

The engine alternators will keep the batteries properly charged when running at cruising speeds.

Battery Charger or Inverter/Charger

 CAUTION!
ENGINE & ELECTRICAL SYSTEM DAMAGE HAZARD!
<i>NEVER</i> run the yacht's engine and the battery charger at the same time.

 CAUTION
<ul style="list-style-type: none"> • The battery charging systems (alternator and battery charger or inverter/battery charger) installed on your yacht are designed to charge conventional lead-acid batteries. • Before installing gel-cell or other new technology batteries, consult with the battery manufacturer about charging system requirements.

- Read the VSR Charging Module Information Sheet.
- **Before** using the battery charger or inverter/charger, read *all* instructions and warnings: (1) on the battery charger or inverter/charger, (2) on the batteries, and (3) in the battery charger manual.
- The battery switches can be in any position during charging.
- The battery charger will charge the boat's battery whenever the boat is plugged into shore power *and* the "BATTERY CHARGER" AC circuit breaker is **On**.
- For the inverter/charger (if equipped) to charge the battery, the inverter *must* be turned **On** and the inverter battery switch must be turned **On**.
- You may use DC powered electrical systems, such as the lights and stereo when the battery charger or inverter/charger is charging, but there will be a corresponding drop in charger performance.

110-Volt AC System

CAUTION

WATER HEATER DAMAGE HAZARD!

- Do **NOT** turn on the water heater AC panel electrical circuit until the water heater tank is **COMPLETELY** filled with water.
- The tank is full if water flows from the tap when the hot water is turned on in the galley.
- Even momentary operation in a dry tank will damage the heating elements.
- Warranty replacements will **NOT** be made on elements damaged in this manner.

NOTICE

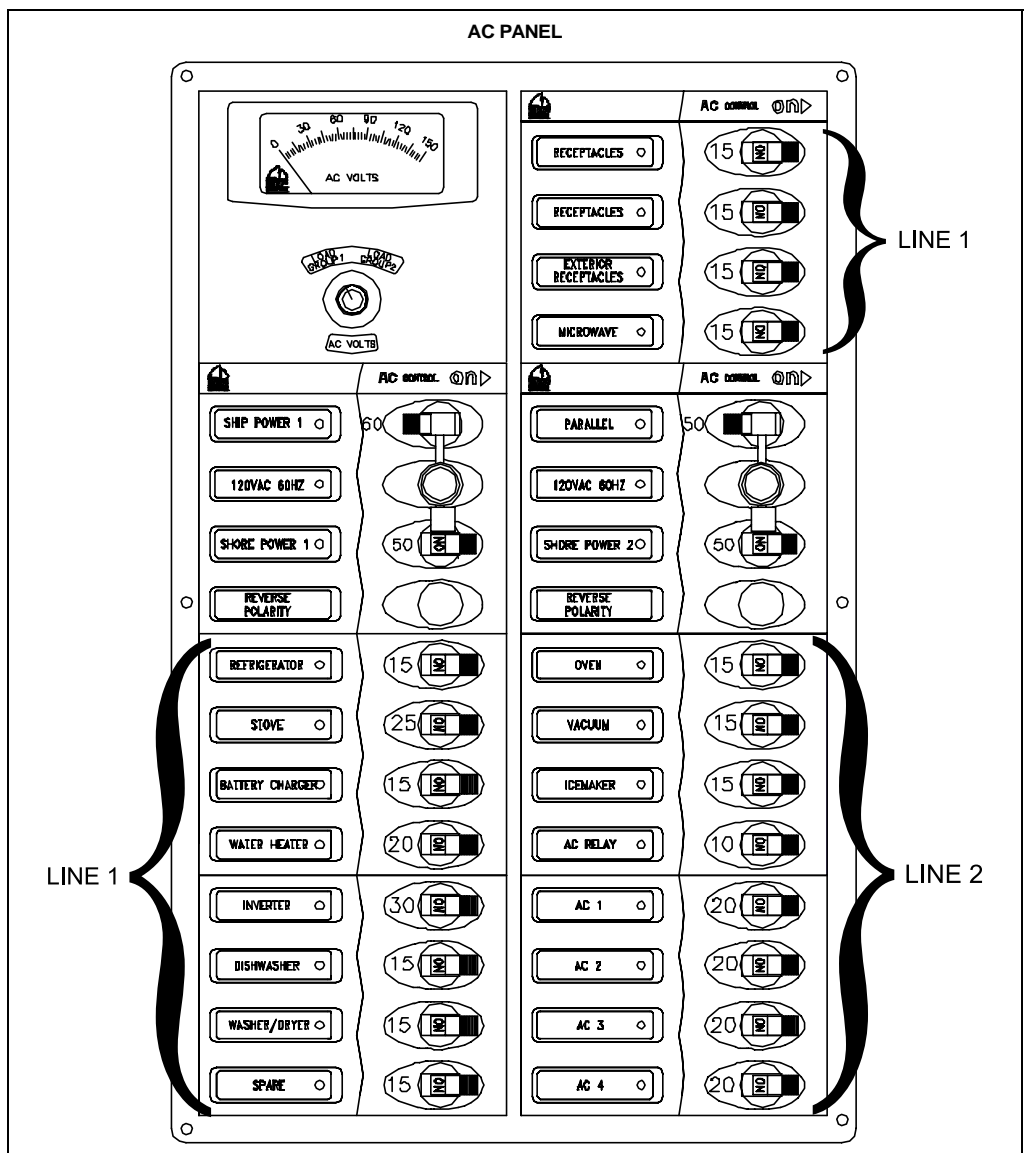

Whether using shore power or generator power, the simultaneous use of several AC components can result in an overloaded circuit. It may be necessary to turn off one or more accessories in order to use another accessory.

- To gain a basic understanding of your yacht's 110-Volt AC system, read the information provided in the handbook, "A Boater's Guide To AC Electrical Systems." If a copy of this handbook was not included in your owner's packet, call 360-403-2198 and one will be mailed to you.
- The AC system can be energized by shore power or generator power.
- The master circuit breakers, located on the AC panel, provide power source selections to AC powered accessories. Individual breakers *must* be turned **On** to supply power to the accessories you wish to use.
- The AC panel may contain inactive circuit breakers for accessories that are not available for this model yacht.





Shore Power

DANGER!





FIRE, EXPLOSION & SHOCK HAZARD!

- **NEVER** alter shore power connectors.
- **ONLY** use compatible connectors.
- **Before** plugging in (or unplugging) the shore power cord to your yacht, make sure all breakers and switches on the AC master panel are turned **OFF**.
- To prevent shock or injury from an accidental dropping of the 'hot' cord into the water; **ALWAYS** plug the shore power cord into the yacht inlet first; then into the dockside outlet. When unplugging from shore power, **ALWAYS** unplug the shore power cord from the dockside outlet first.
- **NEVER** leave the shore power cord *only* plugged into the dockside outlet.
- Only use shore power cords approved for marine use. **NEVER** use ordinary indoor or outdoor extension cords.

WARNING!



SHOCK & ELECTRICAL SYSTEM DAMAGE HAZARD!

- Monitor the polarity indicator lights **EVERY TIME** you connect to shore power.
- If a reversed polarity light turns on when you are connecting to shore power, do **NOT** turn on the main breaker switches.
- Instead, **IMMEDIATELY** unplug the shore power cord (**ALWAYS** from the dockside outlet first) and alert marina management.

WARNING!

SHOCK & ELECTRICAL SYSTEM DAMAGE HAZARD!

- Before each use, check the shore power cord(s) for defects or damage.
- **NEVER** use damaged or faulty cords since the danger of fire and electrical shock exists.
- Do **NOT** pinch shore power cords in doors or hatches, or coil the shore power cord too tightly since these situations can generate enough heat to result in a fire.
- If a shore power cord is dropped into the water, **THOROUGHLY** dry the blades and contact slots before using.



CAUTION



ELECTRICAL SYSTEM DAMAGE HAZARD!

- **NEVER** connect to dockside power outside of North America unless you have purchased the international electrical conversion option.
- Using several AC components at the same time can result in an overloaded circuit. You may have to turn off one or more appliances in order to use another appliance.
- Use double insulated or three-wire protected electrical appliances whenever possible.

- This yacht is equipped with two 30 amp/110-volt shore power inlets or one 50-amp/220-volt shore power inlet.
- The 30-amp/110-volt shore power inlets provide 30-amp/110-volt power to each shore power master breaker.
- The 50-amp/220-volt shore power inlet provides 50-amp/110-volt power to both shore power master breakers.

Connecting To Shore Power

WARNING!

SHOCK & ELECTRICAL SYSTEM DAMAGE HAZARD!

- Monitor the polarity indicator lights **EVERY TIME** you connect to shore power.
- If a reversed polarity light turns on when you are connecting to shore power, do **NOT** turn on the main breaker switches.
- Instead, **IMMEDIATELY** unplug the shore power cord (**ALWAYS** from the dockside outlet first) and alert marina management.

1. Review all hazard information at the beginning of this section, *Shore Power*.
2. Turn **Off** all breakers and switches on the AC master panel.
3. Attach the shore power cord(s) to the yacht inlet(s) first, then to the dockside outlet(s).
4. Switch the "SHORE POWER 1 and/or SHORE POWER 2 " master breakers **On**.
5. Turn **On** the individual component breakers and line breakers as required.

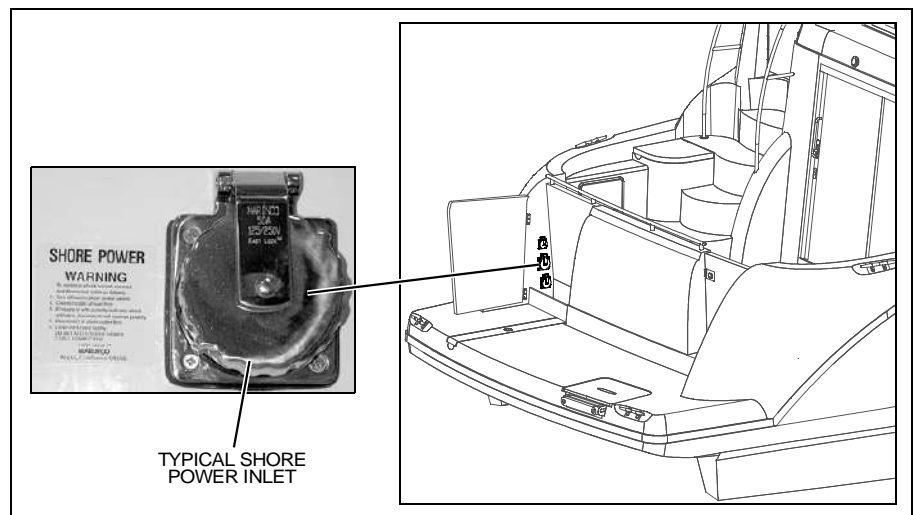

Shore Power Cable Hoist (If Equipped) (50-amp/220-Volt Only)

- The shore power cable hoist allows you to easily feed out and reel in the shore power cable.
- Before using the shore power cable hoist, read the cable hoist manual.

Parallel Switch (If Equipped With Dual Shore Power)**NOTICE**

- **When using the Parallel Switch do *NOT* exceed 30 total amps.**
- **The amperage of each component breaker is shown on the breaker itself.**
- **The voltage on each line can be read by viewing the voltmeter on the Shore power AC panel.**

When only one dockside outlet is available, you can use the Parallel Switch to provide power to both lines.

1. Connect to shore power as described in *Connecting To Shore Power*.
2. Switch the Parallel Switch (transfers power from line 1 to line 2) **On** instead of the 'SHORE POWER 2' master breaker.
3. Turn on the individual component breakers as required.

Inverter Power (If Equipped)

- The inverter allows the batteries to supply AC power to some accessories when your yacht is **not** connected to shore power.
- Primary control is from the Inverter Remote Control Panel. Redundant controls are on the inverter itself.
- **Before** using the inverter, read **all** instructions and cautionary markings on (1) the inverter, (2) the batteries, and (3) all appropriate sections of the inverter manual.
- Energize the AC system under inverter power by switching **On** the inverter master breaker and pressing the **On/Off** switch on the inverter control panel.
- The inverter provides AC power **only** to the accessories on the AC panel.

Generator

! DANGER!



CARBON MONOXIDE POISONING HAZARD!

Generators are a source of dangerous carbon monoxide gas (CO). Check the generator exhaust system for leaks *before* each use.

! WARNING!



FIRE/EXPLOSION HAZARD!

- Use the bilge blowers for a minimum of four minutes *before* starting the generator.
- Leave the blowers on while the generator is running.
- Use of the blower system is *NOT a guarantee* that explosive fumes have been removed. *ALWAYS* use the 'sniff test' to check the bilge areas for fuel vapors.
- If you smell any fuel, do *NOT* start the generator.
- If the generator is already running, *IMMEDIATELY* shut *Off* the generator and *all* electrical accessories and investigate.
- Do *NOT* obstruct or modify the ventilation system.

! CAUTION

SYSTEM DAMAGE HAZARD!

- *Always* make sure the generator's seawater intake seacock is *Open before* starting the generator, and remains open during running of the generator.
- *NEVER* use the generator starter for more than 30 seconds.
- If the generator does not start, wait at least 30 seconds *before* another start attempt is made.
- After starting the generator, wait for the generator to stabilize *before* turning *On* component breakers on the AC panel.

- When your yacht is *not* connected to shore power, the generator can supply 110V/60Hz power.
- *Before* using the generator, read the generator operation manual for pre-start checks and break-in procedures.

Note the following about the generator:

- Polarity has been established in the installation of the generator, therefore the polarity lights will *not* function in this mode.
- Fuel to run the generator is supplied from the starboard fuel tank.
- Periodically replace the filter on the generator to make sure it remains clean and free of debris.
- Diesel generators also have a fuel filter/water separator. Service instructions for the fuel filter/water separator are provided on the filter.
- The coolant mixture installed at the factory consists of equal parts of water and antifreeze (Ethylene Glycol).
- The coolant bottle for the generator is located inside the lazarette.
- Check the generator's seawater strainer for leaks and/or debris *before* each use.
- Gauges are provided on the generator control panel. These gauges monitor the engine functions of your generator.

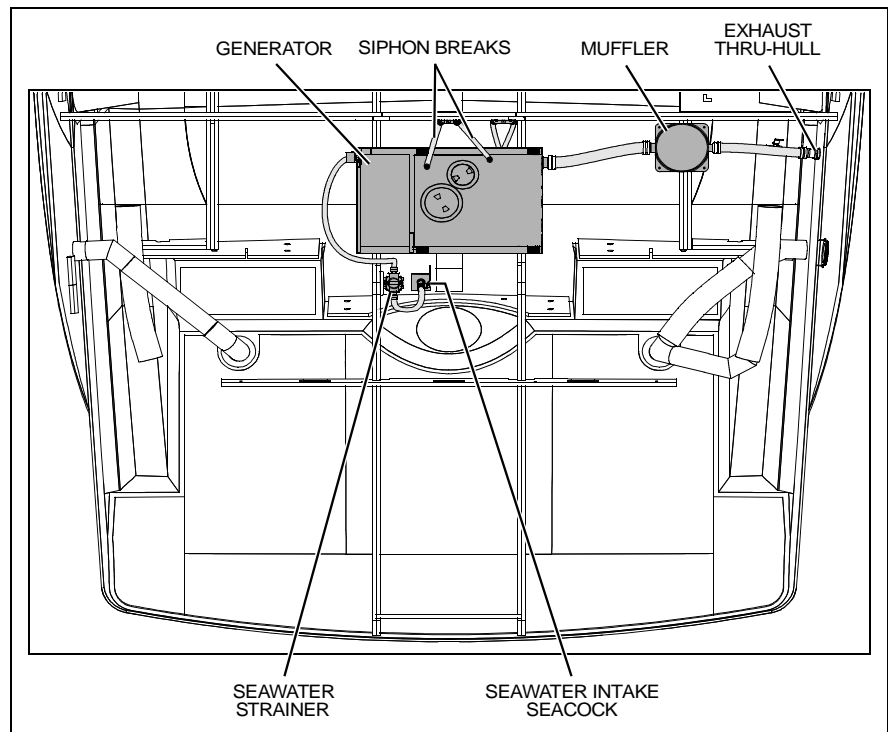

Starting Generator

WARNING!

FIRE/EXPLOSION HAZARD!

- Use the bilge blowers for a minimum of four minutes *before* starting the generator.
- Leave the blowers on while the generator is running.
- Use of the blower system is *NOT* a *guarantee* that explosive fumes have been removed. **ALWAYS** use the 'sniff test' to check the bilge areas for fuel vapors.
- If you smell any fuel, do *NOT* start the generator.
- If the generator is already running, **IMMEDIATELY** shut *Off* the generator and *all* electrical accessories and investigate.
- Do *NOT* obstruct or modify the ventilation system.

CAUTION

SYSTEM DAMAGE HAZARD!

- *Always* make sure the generator's seawater intake seacock is *Open before* starting the generator, and remains open during running of the generator.
- **NEVER** run the generator starter for more than 30 seconds. If the generator does not start, wait at least 30 seconds *before* trying again.
- After the generator starts, let the generator stabilize *before* turning *On* the component breakers on the AC panel.

1. **Run the bilge blowers for a minimum of four minutes before starting the generator.**
2. Leave the blowers on while the generator is running unless your yacht is up to cruising speed.
3. Open the generator's intake seacock before starting the generator. *Keep the intake seacock open while the generator is running.*
4. Refer to the generator manual for starting/stopping instructions.

Electrical Routings

12-Volt DC Deck Electrical Harness

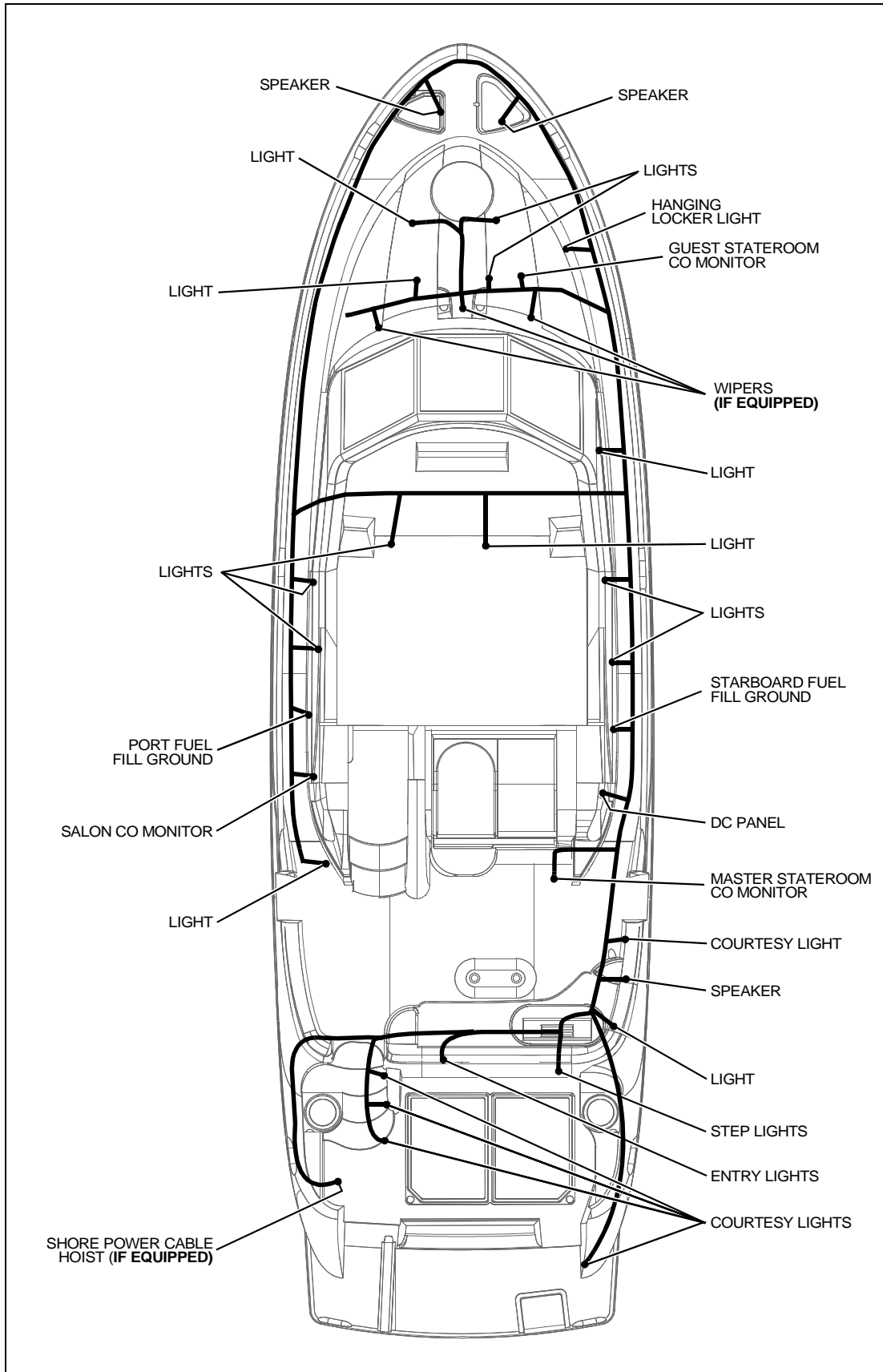

12-Volt DC Hull Electrical System

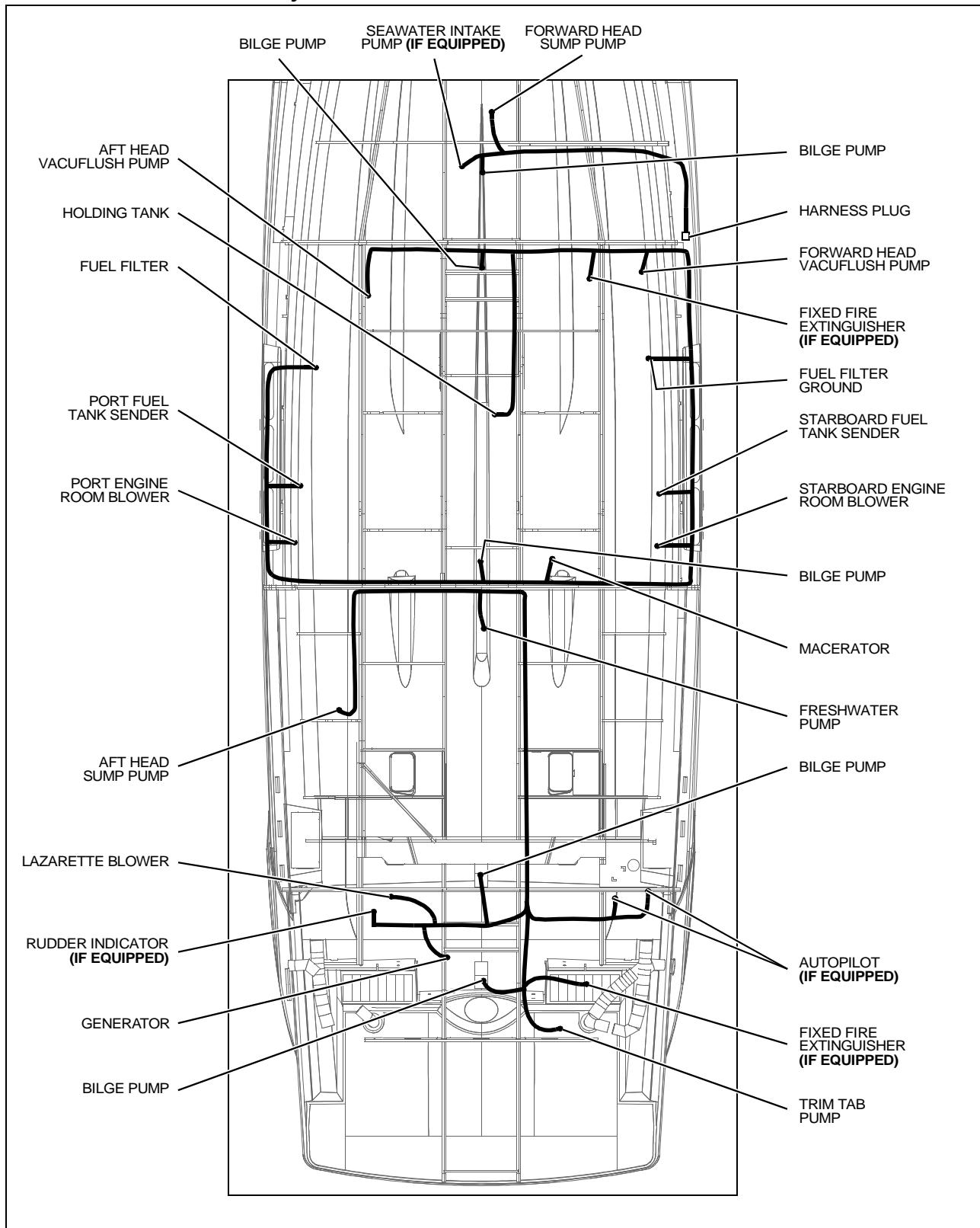

Power Inverter (If Equipped)

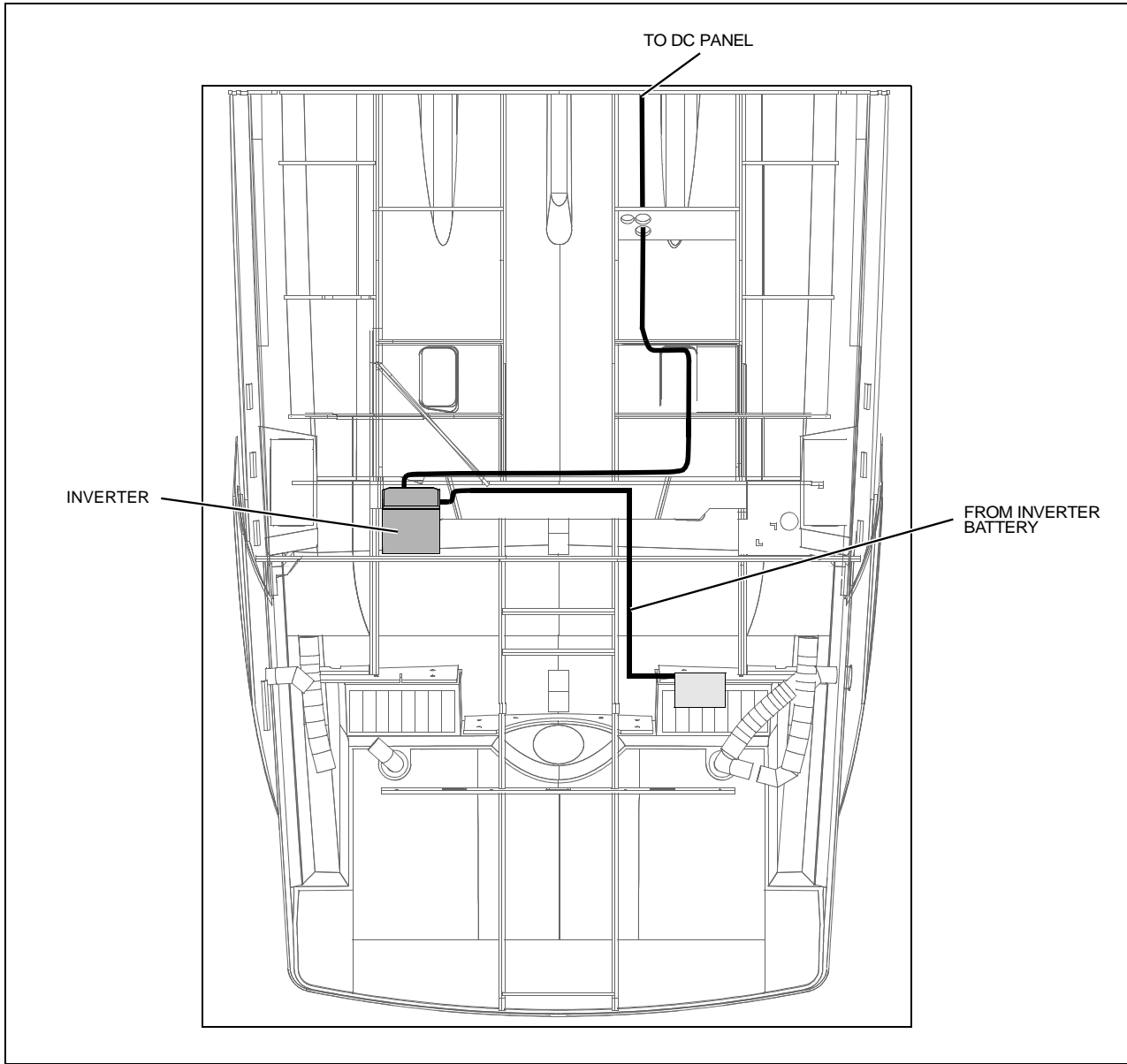

Battery System

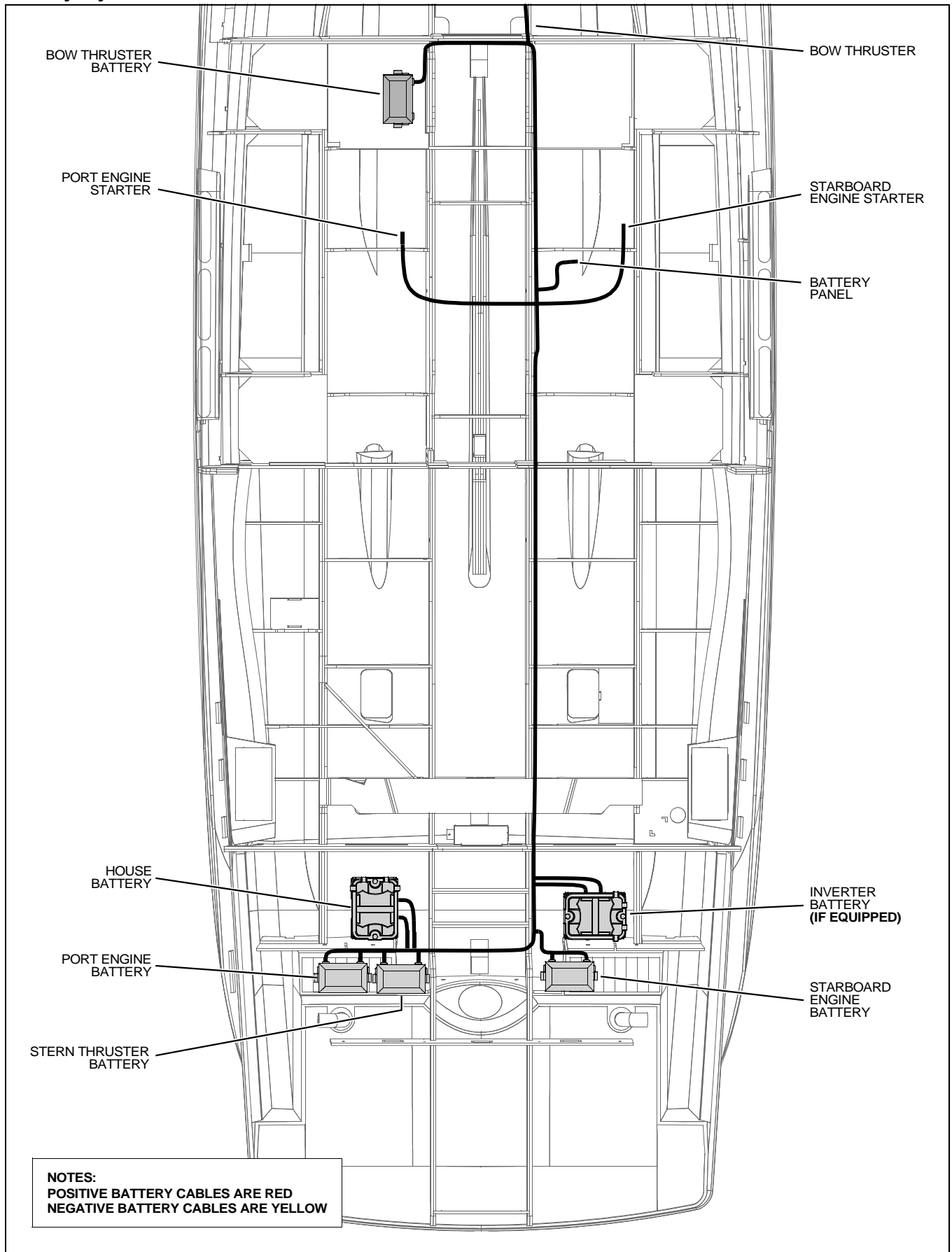

Bonding Harness

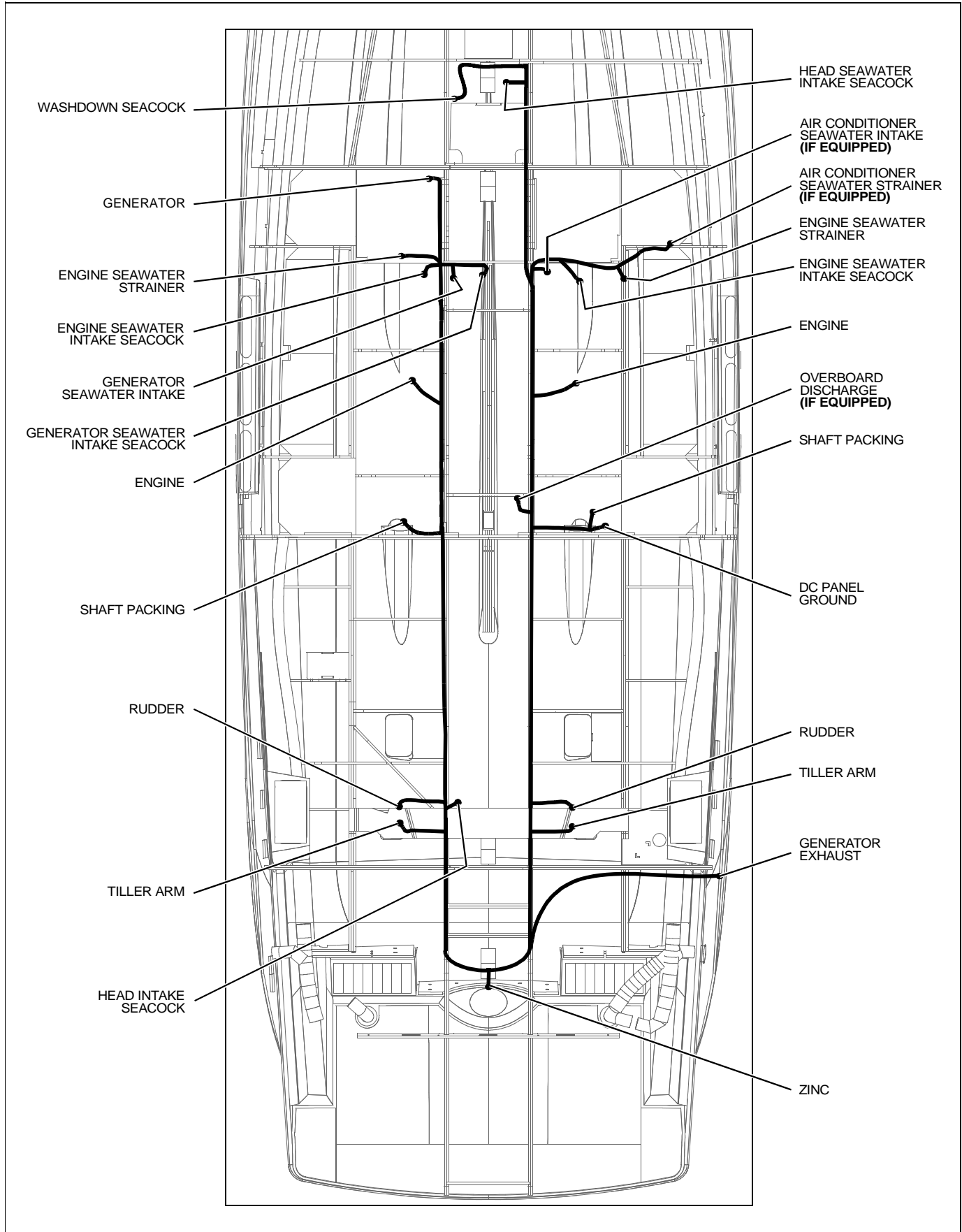

110-Volt AC Electrical Harness

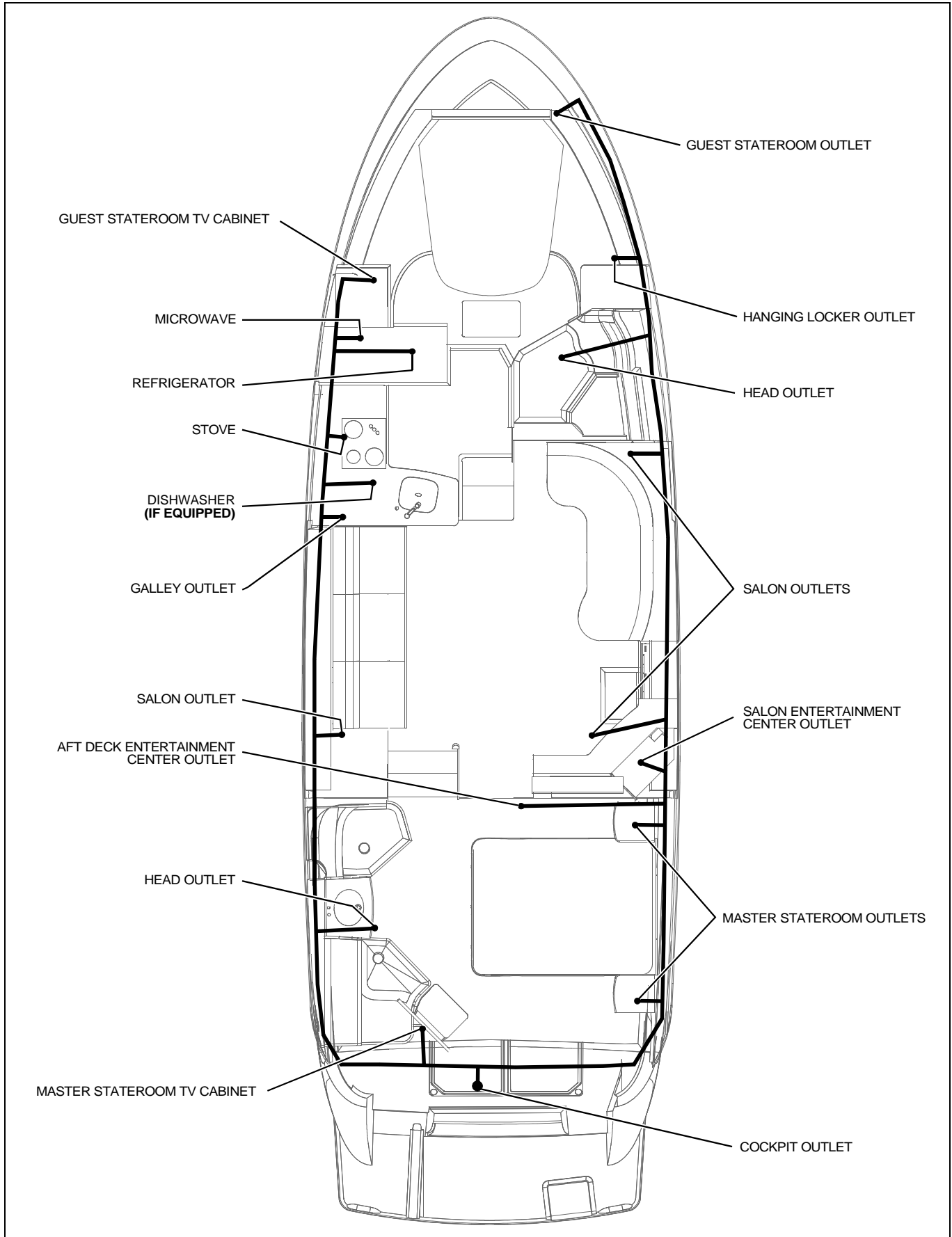

Wiring Diagrams

Engine Electrical System

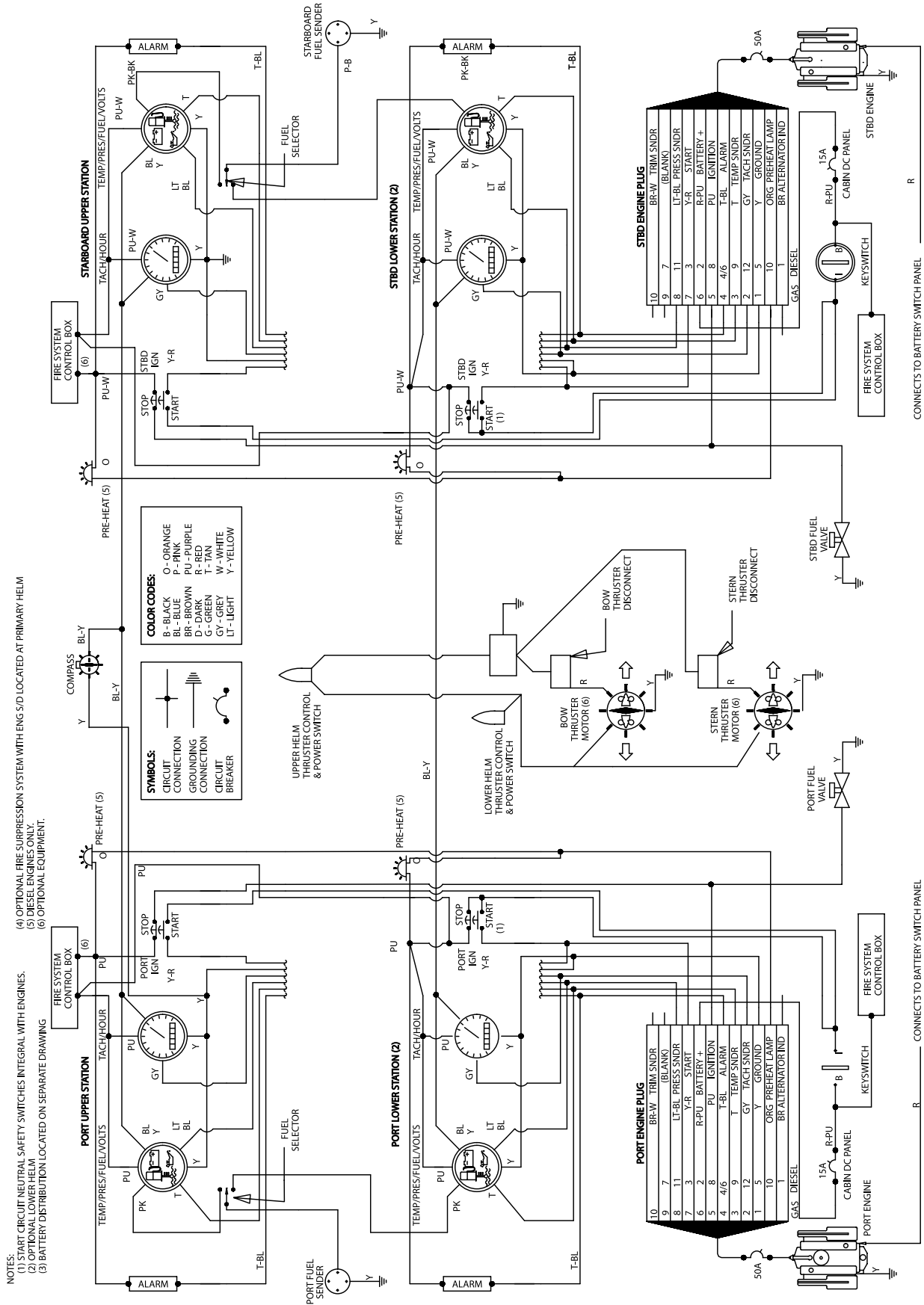

12-Volt DC Command Bridge Electrical System

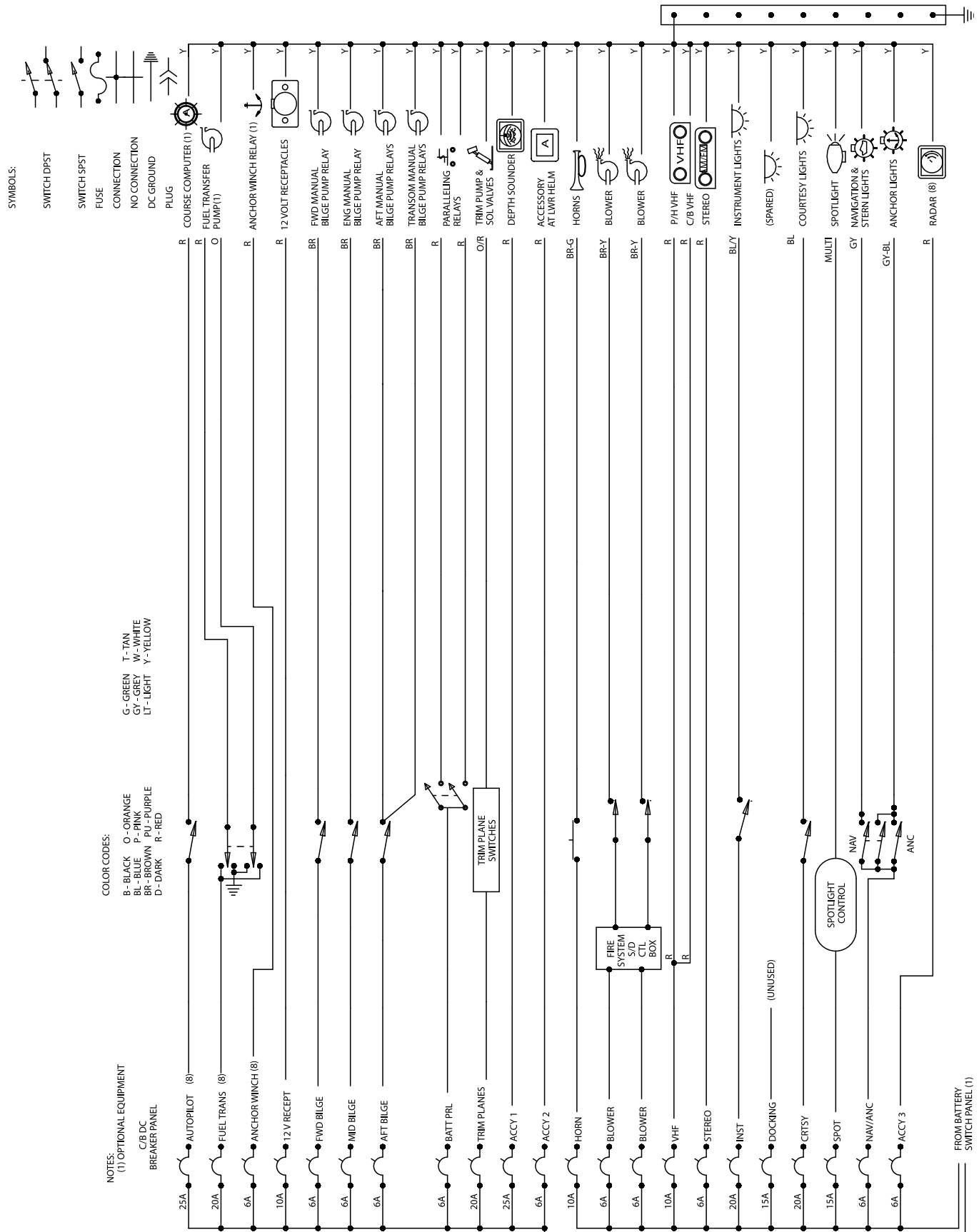

12-Volt DC Cabin Electrical System

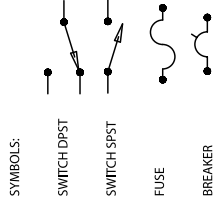
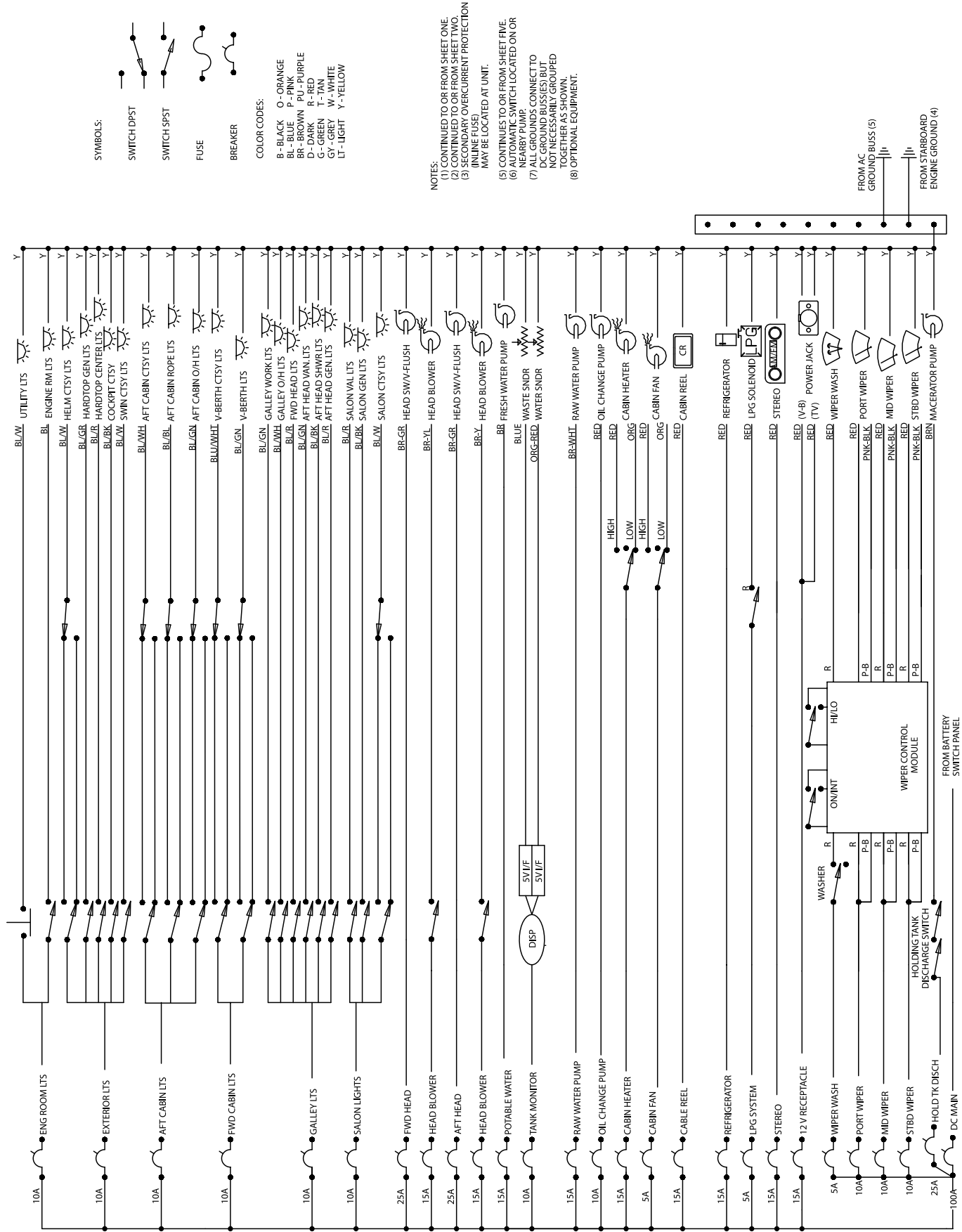

COLOR CODES:

- B--BLACK
- O--ORANGE
- BR--BROWN
- PK--PINK
- P--PURPLE
- D--DARK
- R--RED
- G--GREEN
- T--TAN
- GY--GREY
- W--WHITE
- LT--LIGHT
- Y--YELLOW

- NOTES:
- (1) CONTINUED TO OR FROM SHEET ONE.
 - (2) CONTINUED TO OR FROM SHEET TWO.
 - (3) SECONDARY OVERCURRENT PROTECTION (INLINE FUSE) MAY BE LOCATED AT UNIT.
 - (5) CONTINUES TO OR FROM SHEET FIVE
 - (6) AUTOMATIC SWITCH LOCATED ON OR NEARBY PUMP.
 - (7) ALL GROUNDS CONNECT TO DC GROUND BUSSES) BUT NOT NECESSARILY GROUPED TOGETHER AS SHOWN.
 - (8) OPTIONAL EQUIPMENT.

12-Volt DC Auxiliary Electrical System

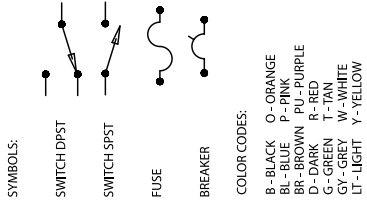

- NOTES:**
- (1) CONTINUED TO OR FROM SHEET ONE.
 - (2) CONTINUED TO OR FROM SHEET TWO.
 - (3) SECONDARY OVERCURRENT PROTECTION MAY BE LOCATED AT UNIT.
 - (4) CONTINUES TO OR FROM SHEET FIVE.
 - (5) NEARBY PUMP.
 - (6) AUTOMATIC SWITCH LOCATED ON OR NEARBY PUMP.
 - (7) ALL GROUNDS CONNECT TO COMMON BATTERY GROUND. GROUNDS NOT NECESSARILY GROUPED TOGETHER AS SHOWN.
 - (8) OPTIONAL EQUIPMENT.

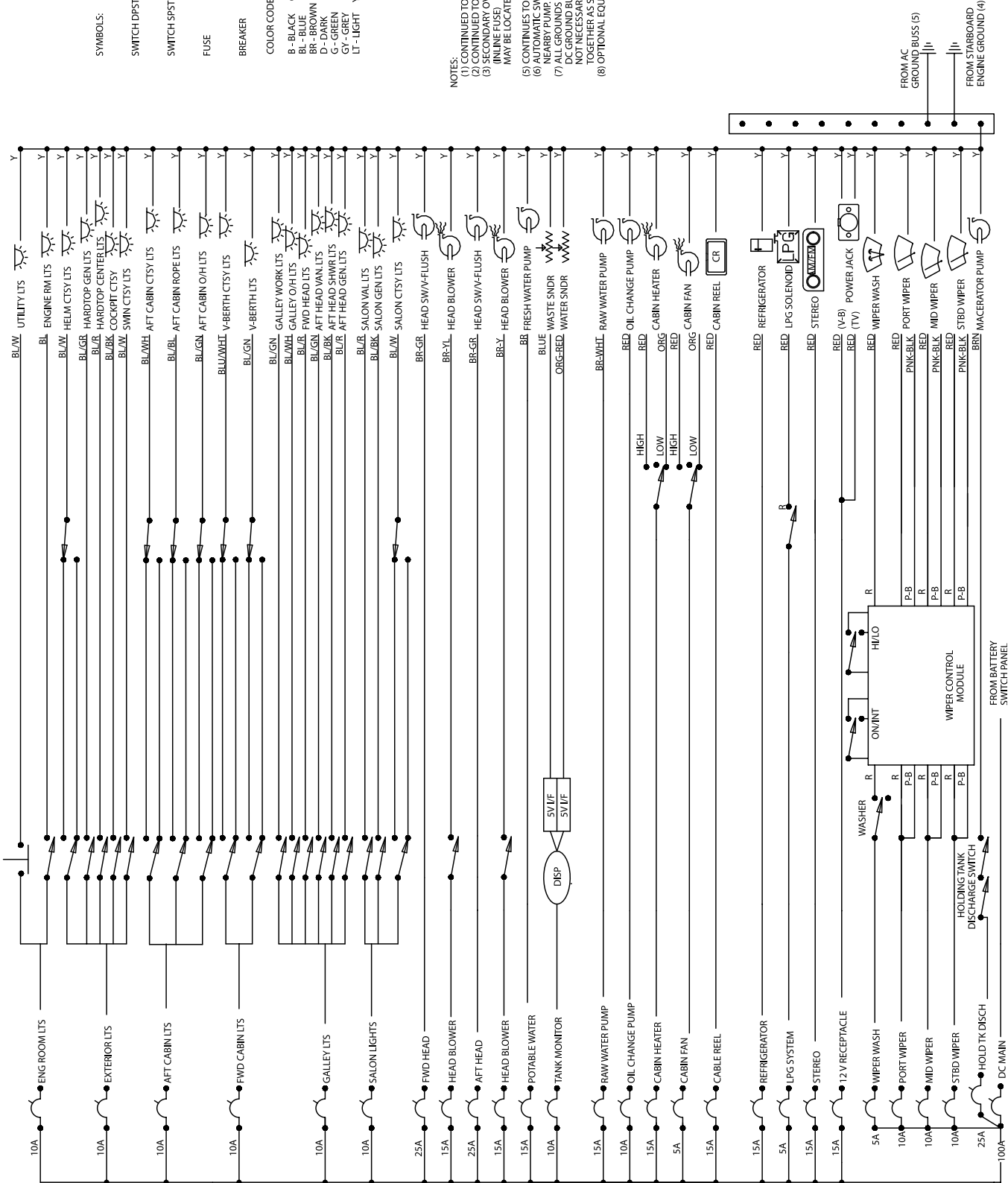

110/220-Volt AC Electrical System

- (1) GREEN(YELLOW) GROUNDING CONDUCTORS FROM ALL AC CIRCUITS CONNECT TO AC GROUND BUSS.
- (2) EXPORT OPTION ONLY.
- (3) OPTIONAL EQUIPMENT.
- (4) WHITE NEUTRAL CONDUCTORS FROM LINE ONE BRANCH CIRCUITS CONNECT TO LINE ONE NEUTRAL BUSS.
- (5) WHITE NEUTRAL CONDUCTORS FROM LINE TWO BRANCH CIRCUITS CONNECT TO LINE TWO NEUTRAL BUSS.

- (6) MASTER BREAKER SLIDING LOCKOUTS PREVENT CIRCUITS FROM BEING SIMULTANEOUSLY ENERGIZED BY TWO SEPARATE OUT-OF-PHASE SOURCES OF ELECTRIC POWER.
- (7) WHITE NEUTRAL CONDUCTORS FROM ISOLATED LINE TWO BRANCH CIRCUITS CONNECT TO INVERTER NEUTRAL BUSS.
- (8) BREAKER VALUES RE-RATED AS APPROPRIATE FOR NON-120V/60 HZ MODELS

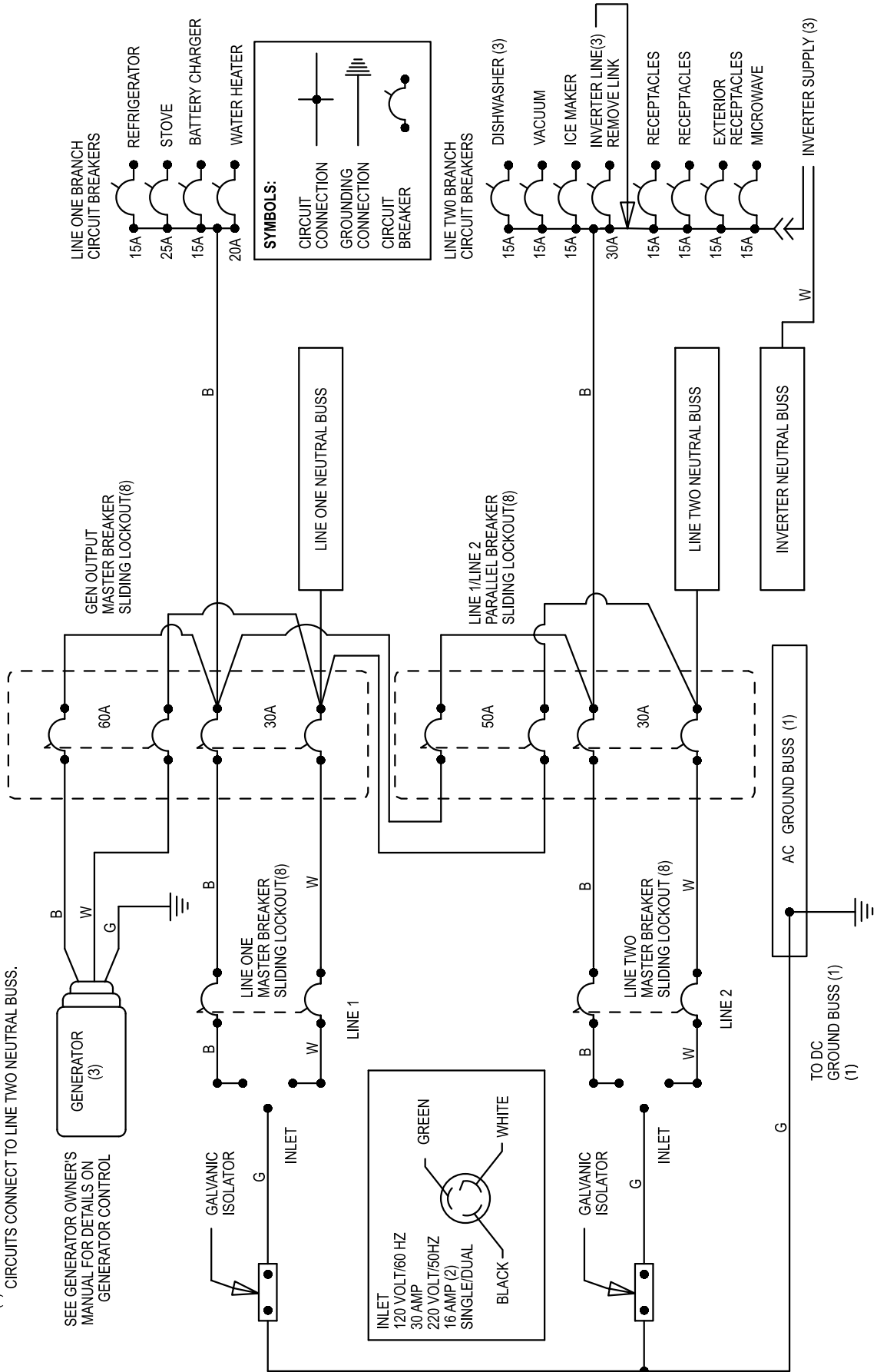

110/220-Volt AC Electrical System (If Equipped)

- NOTES:**
- (1) GREEN/YELLOW) GROUNDING CONDUCTORS FROM ALL AC CIRCUITS CONNECT TO AC GROUND BUSS.
 - (2) EXPORT OPTION ONLY.
 - (3) OPTIONAL EQUIPMENT.
 - (4) WHITE NEUTRAL CONDUCTORS FROM LINE ONE BRANCH CIRCUITS CONNECT TO LINE ONE NEUTRAL BUSS.
 - (5) WHITE NEUTRAL CONDUCTORS FROM LINE TWO BRANCH CIRCUITS CONNECT TO LINE TWO NEUTRAL BUSS.

- (6) MASTER BREAKER SLIDING LOCKOUTS PREVENT CIRCUITS FROM BEING SIMULTANEOUSLY ENERGIZED BY TWO SEPARATE OUT-OF-PHASE SOURCES OF ELECTRIC POWER.
- (7) WHITE NEUTRAL CONDUCTORS FROM ISOLATED LINE TWO BRANCH CIRCUITS CONNECT TO INVERTER NEUTRAL BUSS.
- (8) BREAKER VALUES RE-RATED AS APPROPRIATE FOR NON-120V/60 HZ MODELS

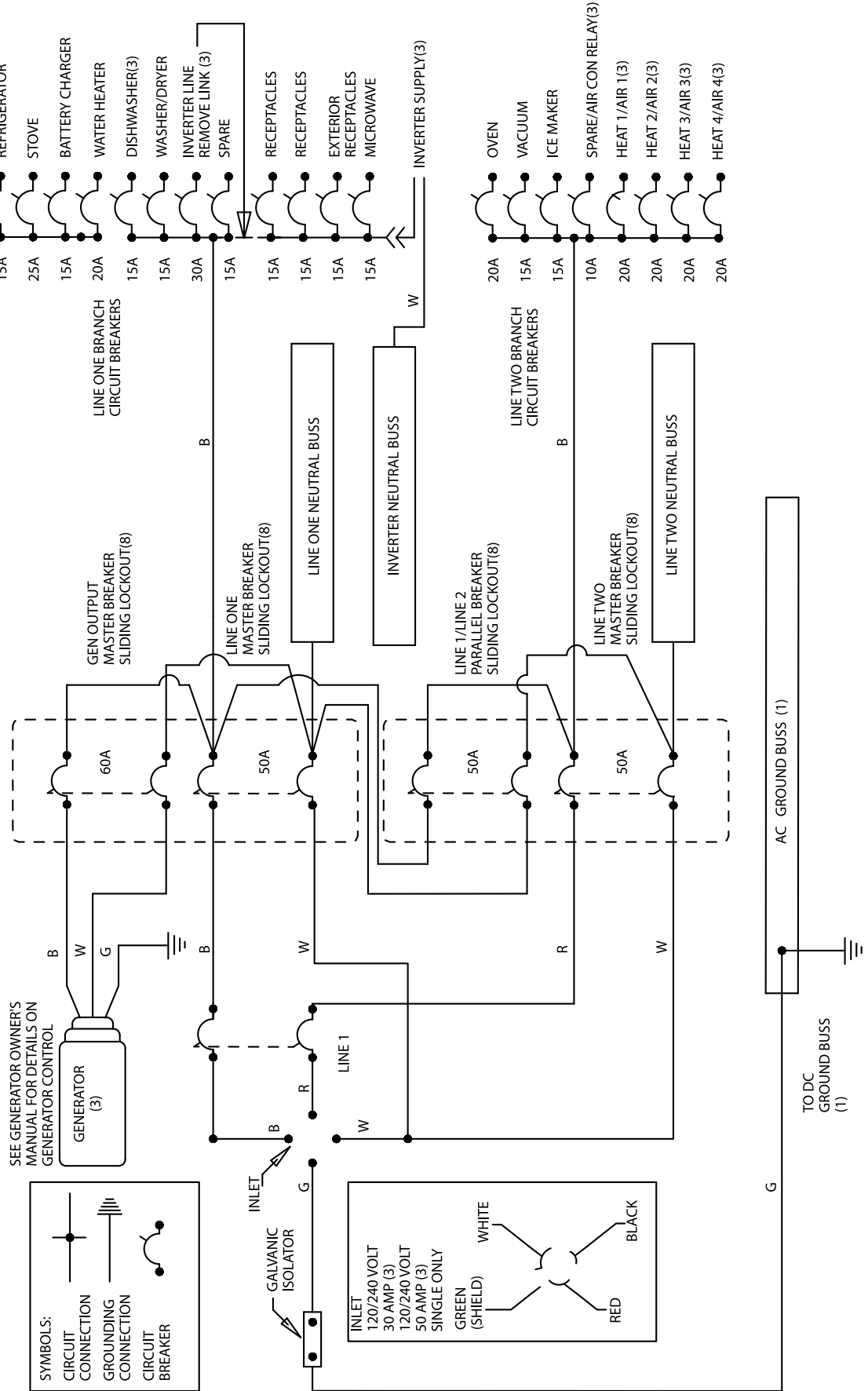

Important Records

Selling Dealer

Name Of Dealership

Address

Phone/FAX/E-mail

Sales Manager

Service Manager

Engines

Manufacturer

Model Name/Number

Port Engine Serial Number

Starboard Engine Serial Number

Oil Type/SAE

Quarts per Engine

Filter Type

Propellers

Manufacturer

Pitch

Model Number

Generator

Manufacturer

Model Name/Number

Serial Number

Oil Type/SAE

Quarts

Filter Type

Fuel System

Fuel Capacity

Filter Type

Plumbing

Freshwater Tank Capacity

Waste Holding Tank Capacity

Key Numbers

Cabin

Ignition

Other

Other

Electronics

Manufacturer

Model Name/Number

Serial Number

Manufacturer

Model Name/Number

Serial Number

Manufacturer

Model Name/Number

Serial Number

Manufacturer

Model Name/Number

Serial Number

Manufacturer

Model Name/Number

Serial Number

Manufacturer

Model Name/Number

Serial Number

Float Plan

Before going boating, fill out a copy of this float plan (or similar) and leave it with a *reliable* person whom you can depend on to contact the Coast Guard or other rescue organization, if you do not return as scheduled.

Description of Boat

Registration/Documentation Number		
Length	Make	Type
Hull Color		Trim Color
Fuel Capacity	Engine Type	Number of Engines
Distinguishing Features		
Distinguishing Features		

Operator of Boat

Full Name		
Male or Female	Age	Health
Address		
Address		
Phone/FAX/E-mail		
Operator's Experience		

Persons Onboard

Full Name		
Age	Health	Phone Number
Full Name		
Age	Health	Phone Number
Full Name		
Age	Health	Phone Number
Full Name		
Age	Health	Phone Number
Full Name		
Age	Health	Phone Number
Full Name		
Age	Health	Phone Number
Full Name		
Age	Health	Phone Number

Survival Equipment

Number of PFDs	Flares (Yes/No)	Mirror (yes or no)
Smoke Signals (Yes/No)	Flashlight (Yes/No)	Food (Yes/No)
Water (Yes/No)	Anchor (Yes/No)	Raft/Dinghy (Yes/No)
Paddles (Yes/No)	EPIRB (Yes/No)	Other
Other	Other	Other
Marine Radio (Yes/No)	Type	Frequencies

Vehicle Description

Make	Model
Color	License Number
Where is the Vehicle Parked?	

Trip Expectations

Departing From	
Departure Date	Departure Time
Stopover 1	
Arrive No Later Than: Date	Arrive No Later Than: Time
Stopover 2	
Arrive No Later Than: Date	Arrive No Later Than: Time
Stopover 3	
Arrive No Later Than: Date	Arrive No Later Than: Time
Stopover 4	
Arrive No Later Than: Date	Arrive No Later Than: Time
Stopover 5	
Arrive No Later Than: Date	Arrive No Later Than: Time
Stopover 6	
Arrive No Later Than: Date	Arrive No Later Than: Time
Final Destination Port (If Different Than Home Port)	
Arrive No Later Than: Date	Arrive No Later Than: Time

If not returned by the date and time listed above, call the Coast Guard or other local authority.

Coast Guard Phone Number
Local Authority Phone Number

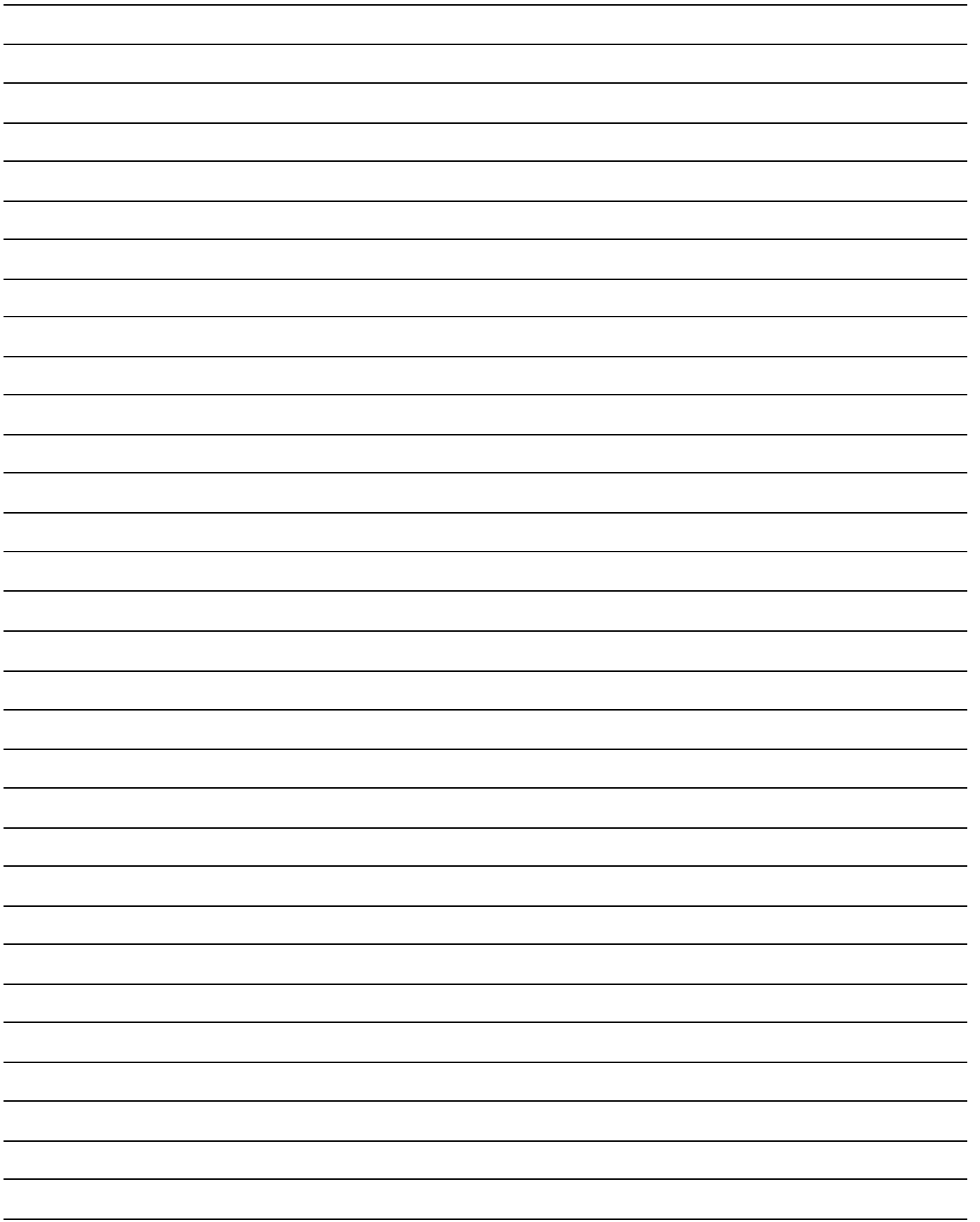

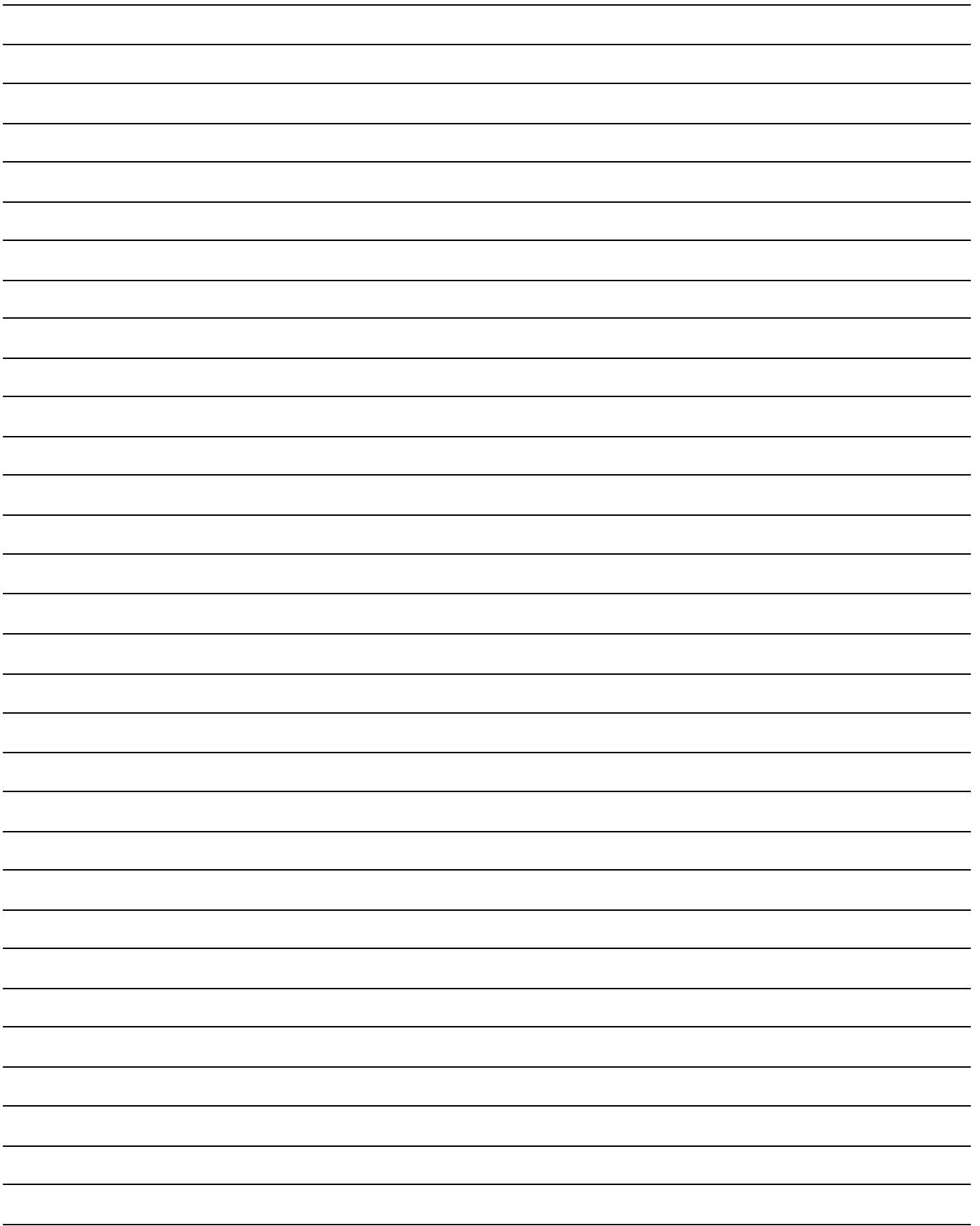

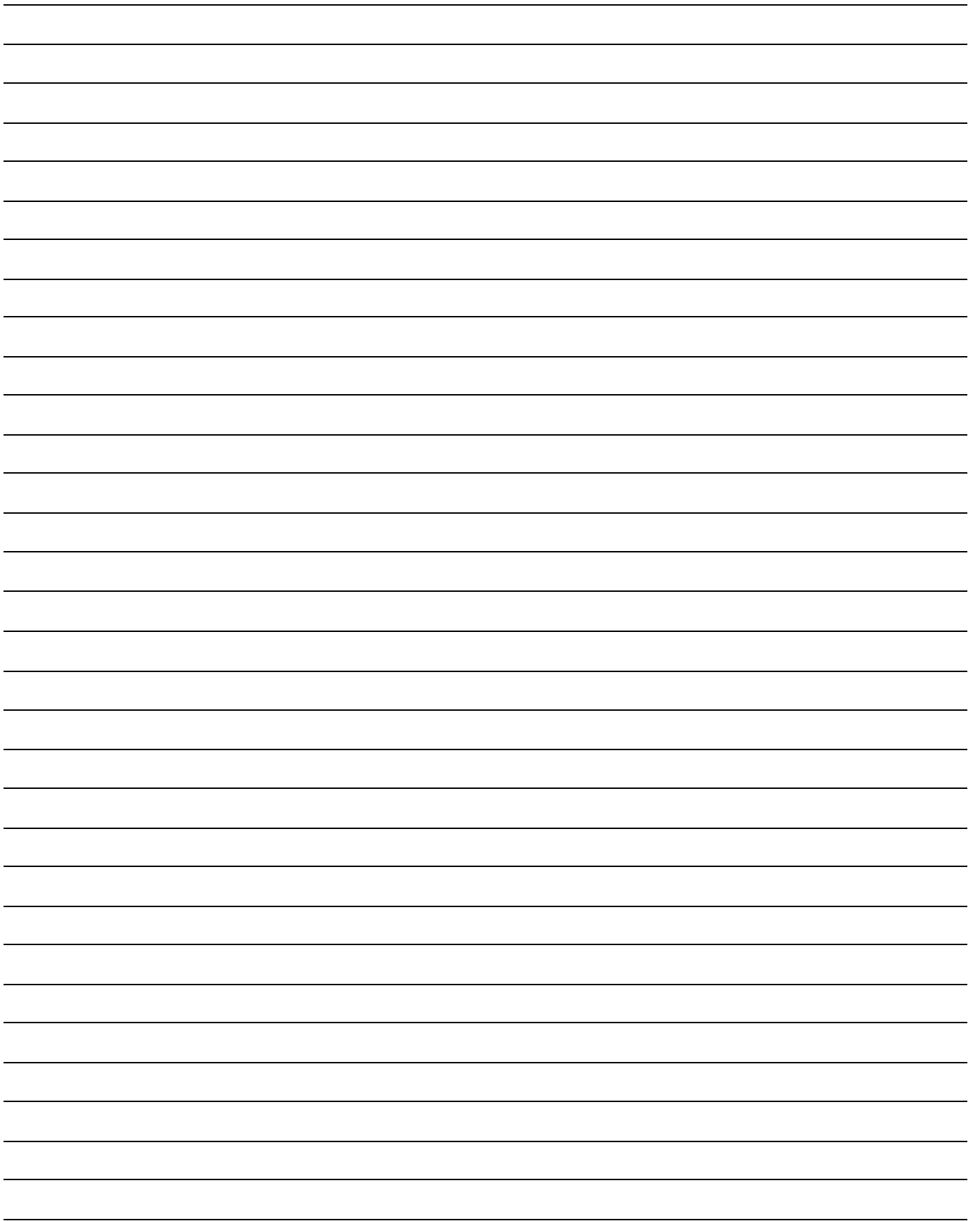

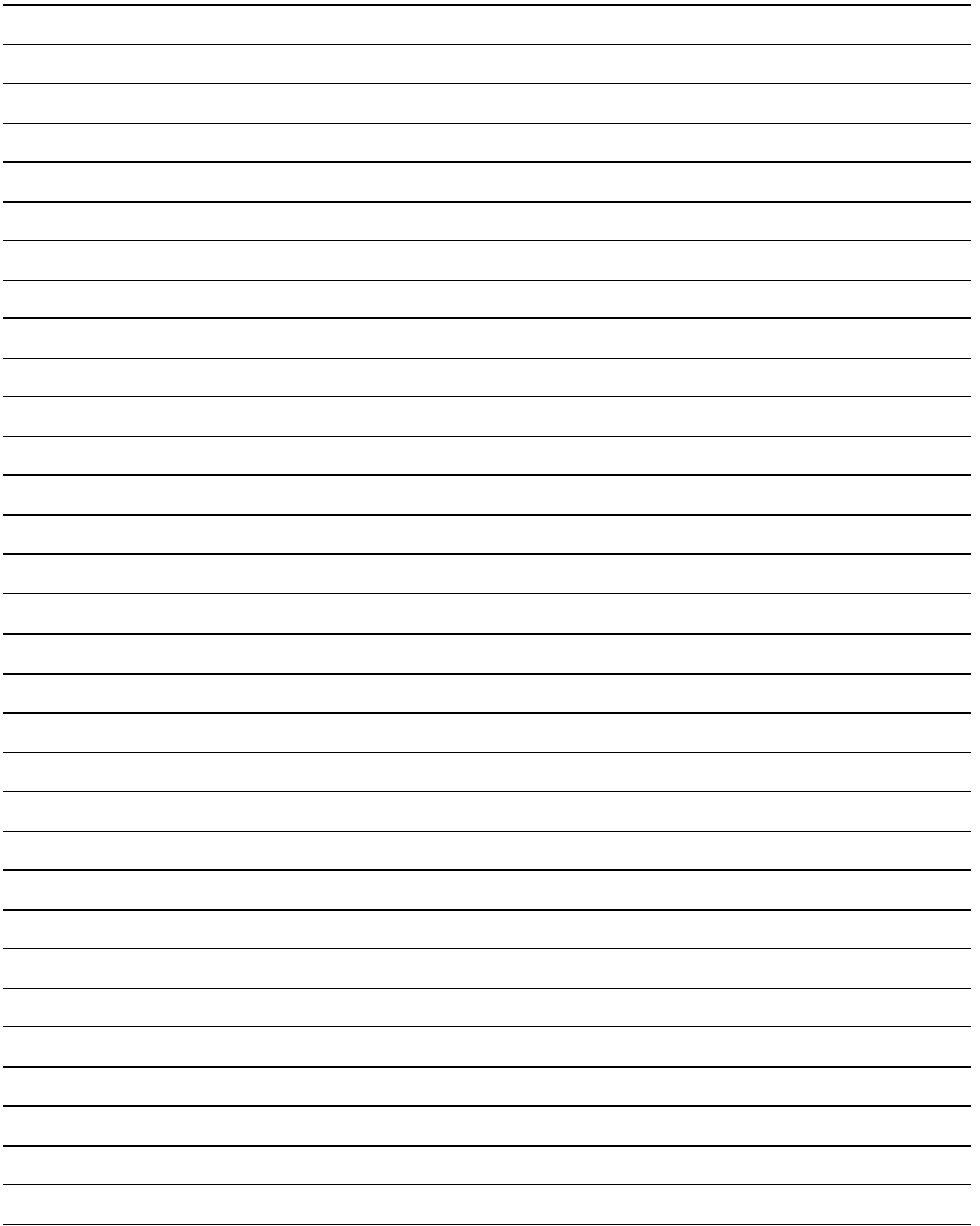

MERIDIAN™
YACHTS

A subsidiary of the Brunswick Boat Group
www.meridian-yachts.com | part # 1781919