

# Hallberg Rassy 38

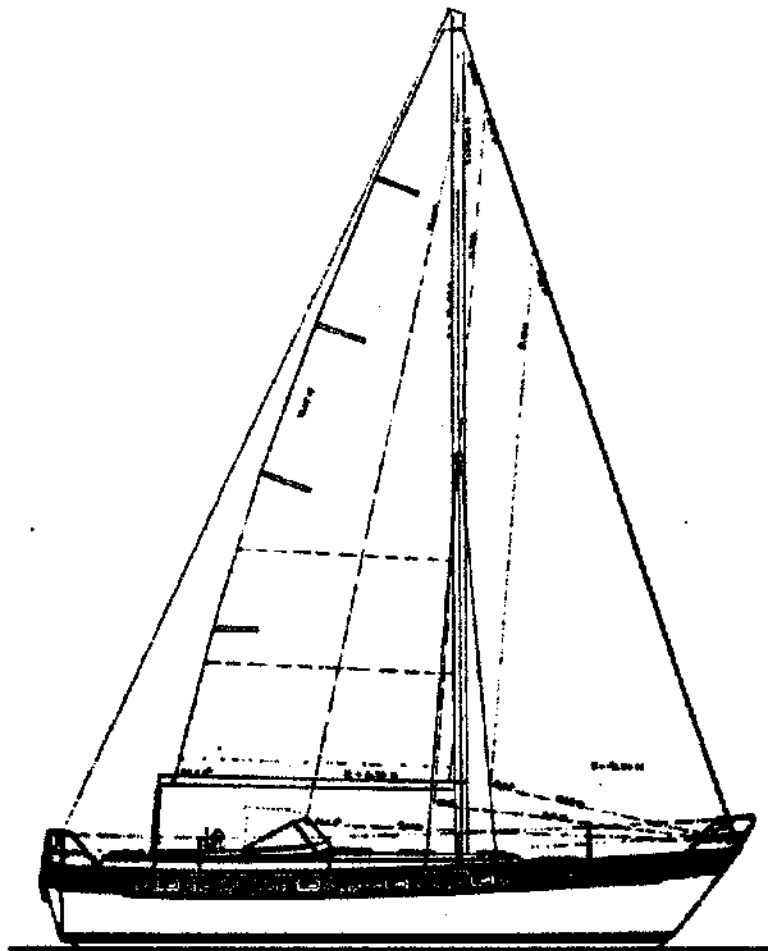

**R** Hallberg Rassy  
S-440 80 Ellös, Schweden. Telefon 0304/50296.  
Telex 2445 Rassy S  
VERKAUFSBÜRO DEUTSCHLAND. 2000 Hamburg 52, Beelenstr. 6, Telefon 040-898342.

We are pleased to hear that you have made the HALLBERG RASSY 38 your choice.

Probably you have sailed for years, you might even have had a boat from our yard before and know many details. Even so, please do not put this booklet away. In this we have tried to put together the most important instructions and hints that apply to the HR 38.

This booklet does not in any way claim to be complete and is not intended as an "Operation Manual" but deals primarily with details which are specifically related to this boat. As a rule the new owner always has to dedicate sufficient time in order to get himself acquainted with his new boat and its constructions. The responsibility for the proper maintenance is also up to the owner.

We wish you many happy days on your new HR 38.

All particulars in this booklet are given in good faith but are not guaranteed.

# HALLBERG-RASSY 38

SPECIFICATION  
SEPT. 1978

Designer: Olle Enderlein

## MAIN DATAS:

Length over all	11,57 m	38'
Length in wl	9,50 m	31' 2"
Beam	3,48 m	11' 5"
Draft	1,75 m	5' 9"
Displacement abt.	8,5 t	18750 lbs
Keelweight	3,7 t	8160 lbs
Sail area	60,5 m <sup>2</sup>	665 sqft
Height of mast above wl abt.	15,75 m	51' 8"
Number of berths	7	
Speed under Power	8,3 knots	

## CERTIFICATE:

Each hull is built according to Lloyd's specifications for "Certificate of Hull Construction" and under the personal supervision of Lloyd's surveyor in the respects of hull, deck and superstructures in GRP, mainbulkheads, engine foundations, chainplates, rudder with fittings, built in fuel and water tanks. Hull moulding Release Note and Certificate are supplied.

## HULL:

GRP. Colour: White. Marin blue decoration stripe above the rubbing strake.

Underwater hull treated with GRP-primer, two component primer and anti-fouling paint. Blue boot top.

Built in longitudinal stringers and tanks in GRP.

Ballast keel, iron, moulded in and completely protected in GRP. Rudder blade in GRP.

Rudder main shaft  $\varnothing$  40 mm bronze.

Heavy cast rudder fittings in bronze.

## DECK AND SUPERSTRUCTURE:

GRP-sandwich construction, 25 mm with polyvinylcellular plastic as core material for strength and insulation.

Colour: Ivory white.

Hull and deck completely joined by overlapping GRP laminate. Bulwark formed in the deck and hull mouldings and fitted with a solid capping in teak.

Handrails, Companionway, Hatchguides, Sole and seats in cockpit are all in natural teak.

Laid teakdeck on top of GRP deck,  $\frac{1}{2}$ ". The deck is provided with four 1" scuppers draining below the waterline.

Two  $1\frac{1}{2}$ " scuppers from the watertight and selfdraining cockpit.

## SPARS AND RIGGING:

Mast and boom in anodized light alloy profiles. Mast:  $239 \times 162$  mm 6,1 lbs/foot. The mast is provided with a special channel for later installment of cables for electrical equipment.

The mast is stepped on the cabin top directly over strengthened bulkhead.

Modern Jiffyreef.

2 halyard reel type winches, Lewmar 2 or equiv.

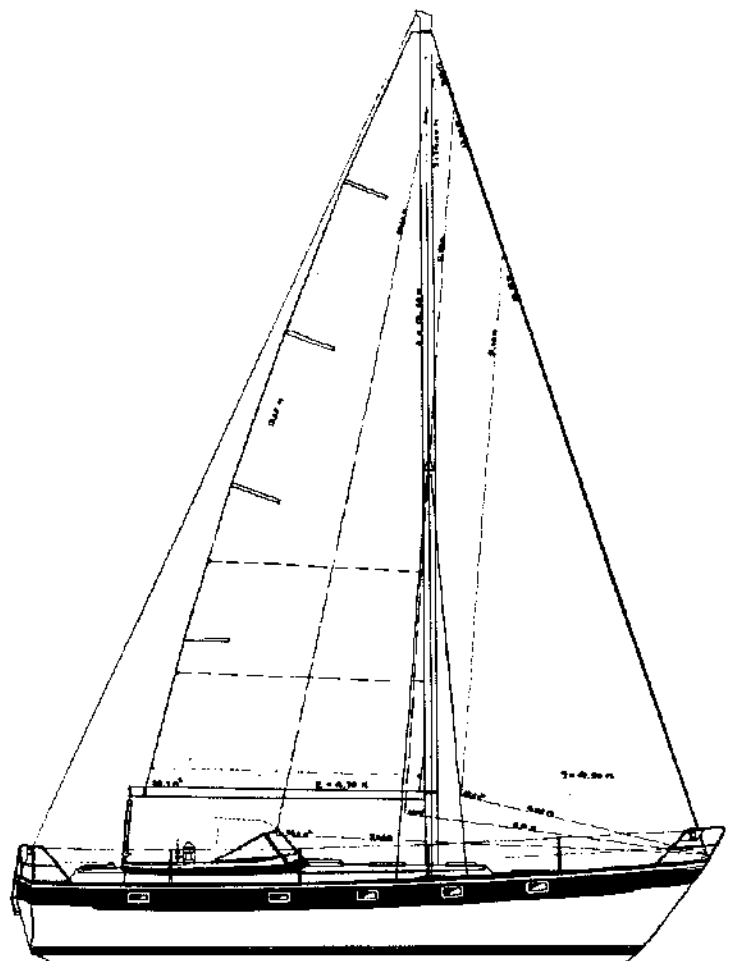

Scale: 1:125

On the mainboom two Lewmar 8 for reef and outhaul. Boom vang tackle.

Internal halyards.

Decklight.

Fittings for spinnakerhalyard at mast-head, pennantlines.

Mainsheet 6-part on x-track with traveler.

Foresailsheet.

Two Lewmar adjustable track cars for forsailsheets on 10' Lewmar light alloy track.

Fore stay in  $\varnothing$  10 mm.

Main shrouds and stays in  $\varnothing$  8 mm ( $\frac{5}{16}$ ")  $1 \times 19$ .

Turnbuckles  $\frac{5}{8}$ ".

Jib halyard 6 mm ( $\frac{1}{4}$ ")  $7 \times 19$ . Main halyard 5 mm.

Boomlift.

Stainless chainplates.

Stemhead fitting in stainless steel with incorporated anchor roller.

## SAILS:

First class workmanship in terylene or dacron, soft treated cloth. Main with slides for track in mast.

Mainsail: abt.  $31,5$  m<sup>2</sup> 320 grms/m<sup>2</sup> 345 sqft. Two reefs in mainsail.

Workingjib: abt.  $29,8$  m<sup>2</sup> 230 grms/m<sup>2</sup> 330 sqft.

## EQUIPMENT:

Sheetwinches, two Lewmar 44, three speed, clamcleats.

Winchhandles 10", "Lock in", three provided. One winchhandle pocket.

Four 15" mooringcleats.

Two 10" mooringcleats, amidships.

Pulpit, open type for easy embarkment.

Built in rubbingstrake with bronze profile.

Double lifelines with four pairs of conical stanchions. Height 28".

The yacht is delivered with permanent windscreens with heat treated glass in light alloy frames.

In the windscreen one panel is opening and provided with electric wiper. A canvas canopy attached to windscreen protects the forward part of the cockpit.

Portlights in 10 mm acrylicglass and light alloy frames, all opening.

Compass: Sestrel major or equiv.

Whale Gusher 10 bilgepump.

International navigation lights, 4".

One anchor 45 lbs., folding.

One anchorline 100'.

Four mooringlines 33'.



## Hallberg-Rassy

HALLBERG-RASSY VARV AB

S-440 80 ELLÖS - SWEDEN

PHONE 0304/502 90

Measurements for transports, etc.

Weight with empty tanks about 8,5 tons (about 19.000 lbs).

Overall height without windshields from underside keel to top of GRP coaming (compass, steering wheel and pulpit removed) 3,65 m (12'- 0").

Overall beam including rubbing strake 3,52 m (11'- 7").

If the boat is to be lifted with strops in a crane or travel lift, the after strop is placed about 0,5 m forward of the screw and the forward strop about 0,5 m forward of the mast step. The centre of gravity is located on a vertical line 0,6 m (2'- 0") forward of the top of the forward GRP cockpit coaming (where the central opening windshield panel is screwed).

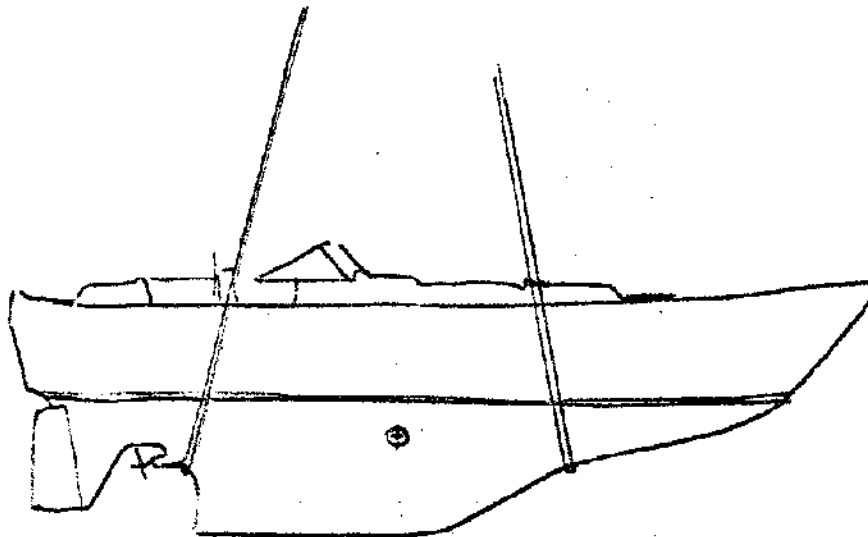

Length over all means length from the rear end of the transom to the foremost end of the stem and is 11,57 m (38'- 0").

For road transport the windshields, compass, steering wheel and pulpits can be removed with the tools normally carried in board.

The length of the main mast without any instruments or antennas is 14,05 m (46' - 1").

The height of the main mast over water line is 15,75 m (51' - 8") without any instruments, etc.

The small plans in the specification are made in scale and could give additional information. Measurements, specially as regards sails and rigging, are best checked on board.

When lifting on a slipway, it is important that the boat will not rest directly on iron beams or rails. Two wooden blocks 8" wide are sufficient. An additional strut under the bow can give additional safety against tipping over under extra loads forward.

When stored for the winter, it is important that the boat is horizontal, so the deck drains will take any water or snow that elsway will stay on deck. This can be checked by a water lever under the flat keel.

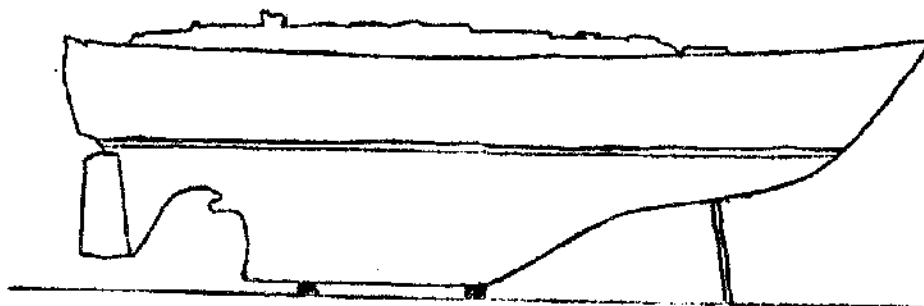

### Mast and rigging

If the boat is not delivered at our yard, the new Owner in most cases takes care of the rigging of the boat. The halyards and sheeves should be checked and the stays and shrouds attached to the mast. Do not forget to mount the top light and to check with a battery that all lights work. The cross tree is best mounted according to the sketch below. The correct adjustment of this is not only important for the look, but also for the safety of the mast.

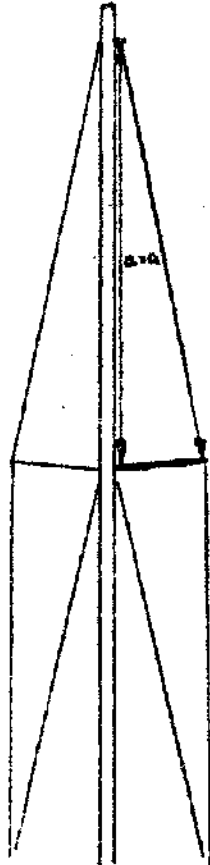

If a shroud is stretched along the mast and marked at the height of the spreader base fitting, this is the correct position for the spreader tip on the shroud.

The short lengths of PVC hose that come with the boat are used as protection over the rigging screws and must be fitted before stepping the masts. All rigging screws are best fitted so right turning will tighten the stay.

### The mast

The mast is placed in the maststep with locating fin in the slot slot. Only one position is possible. Stays and shrouds are attached and first loosely set to prevent the mast from falling. The fore and after stays are set to about 2,000 lbs. The rake should be about 4°. After this the forward lower shrouds are set and adjusted until the mast is vertical athwartships and at the same time the mast is pulled forward at half height about 1". Next come the top shrouds, which are also set to about 2,000 lbs. The after lower are only set so loosely that the 1" bend is still there.

The tension in the fore and aft stays and the top shrouds should be higher than the forward lower and the after lower next to loose.

### Tuning of the rigging

The complete rigging must be kept under observation during the first hours of sail. The rigging and mast will settle after the first hours in hard wind and a retuning must be done.

It is true that a tight forestay helps the performance on the wind but puts also heavy loads on the hull. The use of hydraulic or mechanical jacks for the back stay must be made with care and heavy permanent loads are to be avoided.

The purpose of the tuning of rigging is to provide a straight mast when sailing well heeled. S-bends and top bending forward are to be avoided.

The mast and rigging can under special conditions vibrate. This is caused by the aerodynamically favourable form of the mast and the high tension in rigging. They appear almost only when the boat is moored with a strong breeze blowing from abeam.

The vibrations are natural and harmless but if disturbing can in most cases be cured by hoisting the supplied "slip of sail" with the rope in the mast track. This will break the airflow around the mast.

A leaflet from the sparmaker is available for the owner who wants to go in detail with the rigging and trimming of the masts.

### Start and running of engine

All boats are tested in the water prior to the delivery from the yard regardless if the boat is to be trucked away or taken over at the yard. The motor has been run and is ready to start except during the winter, when the engines are winterized again after testing. When the boats are trucked away from the yard only enough fuel for testing is filled.

### Starting

Under the main accommodation ladder are the two main switches. One for the engine starting circuit and one for the general purpose circuit. To start the engine, the engine main switch must be on.

Further follow the Volvo Penta instruction book, page 10, "produce before starting, starting and stopping". Note the instructions for running-in and the warning plate at the instrument panel.

### Gear change

The engine is fitted with single lever controls. Shifting should be made by firm slow movement on the lever, allowing the engine RPM to drop before engaging the gear in the opposite direction.

### Cavitation

Below 1000 RPM the thrust of the propeller is very low and the running irregular. Over 2000 RPM when manoeuvring the propeller will cavitate especially in reverse. That means that the propeller loses its grip in the water and the thrust drops. Avoid high RPM in manoeuvres especially in reverse.

### The turning effect of the screw

The screw is left hand. The bow is turning to port at astern manoeuvres. With the rudder hard over to port and engine shifting between slow ahead and slow astern the boat will turn 360° at the spot. As soon as the boat has started to move, ahead or astern, full steering control is obtained.

### General

Before getting used to the boat berthing in close quarters should be avoided in heavy wind. The fine steering control that is obtained on the vessel when going astern often makes it better to back out than try to turn the boat into the wind against a strong crosswind, if the room is not sufficient to pick up headway. After some practice it is surprising to see the precision which can be obtained in manoeuvres also in close quarters and critical conditions.



## S A I L

### Sail setting

As a general rule the tension on the bolt ropes of all sails should be adjusted so that no wrinkles will appear at these but not so tight as to form folds along spars and stays. This means that the tension has to be adjusted to the windstrength. The halyard winches and the internal purchase on the outhaul make this possible when on the wind.

The drums of the main- and head sail halyard winches have two separate sections. When hoisting a sail the halyard is rolled up on the outer section until only a few feet are left. These are rolled up on the narrow inner drum to avoid that the wire will bury and bind under tension. The brake has a free-wheel effect and is best set before starting to hoist.

**WARNING!** Do not release the brake to let down the sail with the winch handle still in the winch. The spinning handle may break an arm.

### Hints on sail carrying and trimming

Light genoa  $46,5 \text{ m}^2$  (510 sqft) can be carried on the wind up to force 5 (18-20 knots). It is sheeted outside the shrouds but inside the life lines.

Working jib  $29,8 \text{ m}^2$  (330 sqft) is the best sail from 16 knots up to 35 knots on the wind. It is sheeted outside the shrouds or between the lower and the top shroud and inside the life lines.

Hard wind jib  $18,5 \text{ m}^2$  (200 sqft) is the best headsail from about 30 knots and up.

### Main sail

The main sail is carried without a reef up to force 6 together with the working jib, but can as reefing is easier than shifting a fore sail, be used reefed together with the light genoa.

The main sail is best carried on the boom with a sail cover when not in use.

Headsails should be folded before bagging to avoid too bulky sail bags.

All sails are made in synthetic cloth and require no "break in" sailing. They are fairly water resistant and can if required be stowed wet. The sails must in that case be dried at first opportunity, as they can be miscolored by mildew.

### Preparation for reefing

On each side of the main boom a movable loop is fitted. There are two reef lines running inside the boom, one on each side appearing in the ends of the boom. The shorter one on SB side is for the first reef and the longer line on the port side is intended for the second reef.

When the mainsail has been bent on in the usual way, the outer end of the reef line for the first reef is taken through the eye for the lower reef in the sail and is fixed to the loop on the port side with a bowline knot. The reef line for the second reef is taken through the second reefing eye in the sail and to the loop on SB side. The travellers with the loops are moved along the boom to give a  $45^{\circ}$  lead in when the sail is stretched along the boom.

### Reefing

1. Head about  $45^{\circ}$  from appearant wind.
2. The boomlift is set but the boom is not lifted.
3. With winch handle is firm grip the brake is slowly released and the sail is allowed to come down until the eye of the first reef can be hooked at the tack.
4. The reef line for the first reef is taken to the winch on the boom and is tightened until the sail is properly stretched along the boom.
5. The halyard is retightened not forgetting to push the wire over on the inner drum for the last turns.
6. The lift is released.

A reefed sail should be flat and the position of the loops on the boom may have to be adjusted. The second reef is taken in the same way. To let out a reef, the same operation is made in reverse.

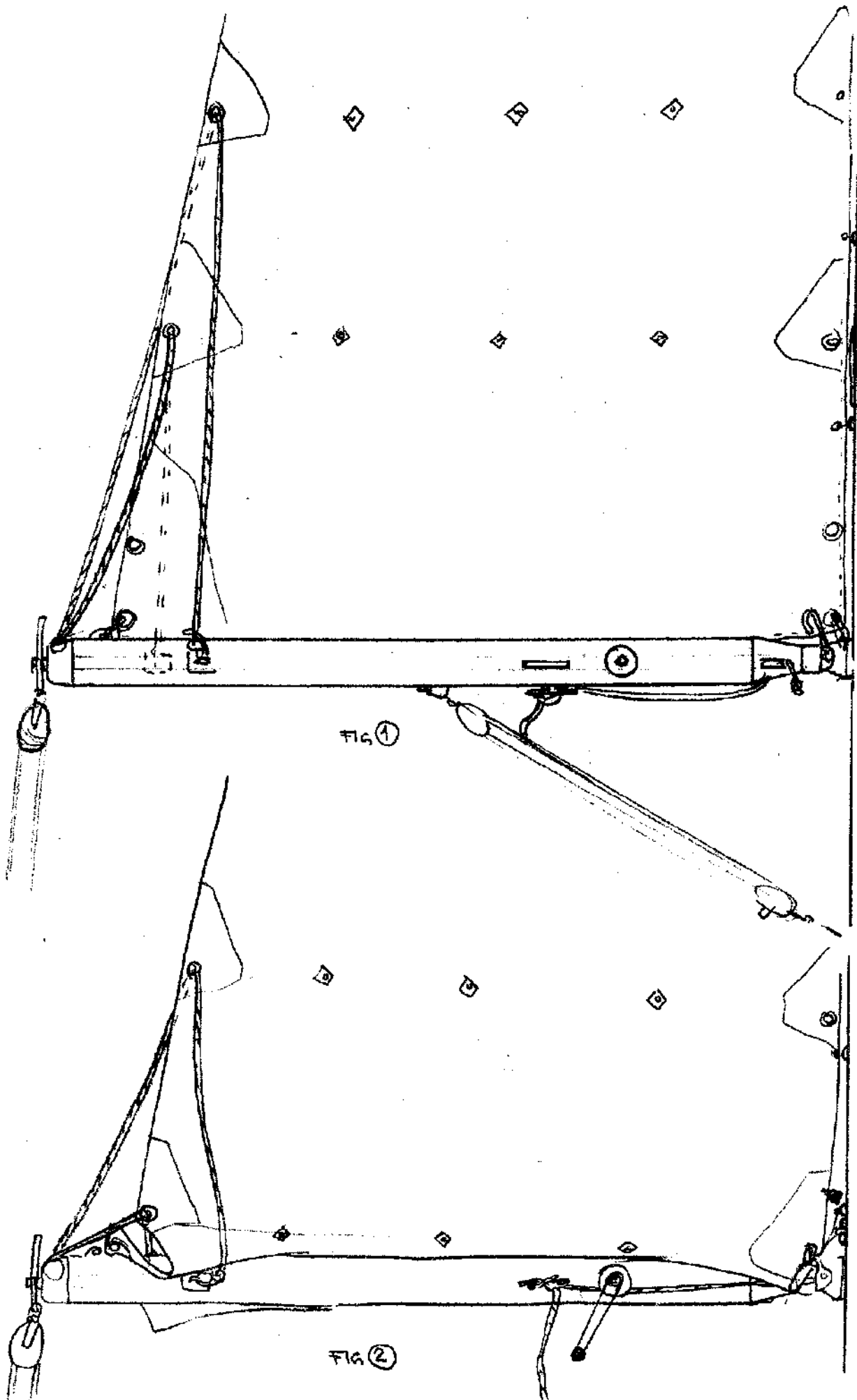

## ENGINE INSTALLATION

For the engine itself we refer to the Instruction book from Volvo Penta. This should be read carefully.

### Engine hold down bolts and engine alignment

After twenty hours running and once every year the engine hold down bolts should be checked and tightened if loose. The alignment of the engine and the propeller shaft must be checked by feeler gauge at the flange by a competent mechanic.

### Venting of the fuel system

In the event of running the fuel tank empty or a filter has had to be cleaned, the fuel system must be vented. This is described in the Instruction book. It should be noted that the "banjo screw" mentioned as a standard has been replaced by a valve screw that should normally be open but is closed for the venting operation.

### Propeller shaft stuffing box

The propeller shaft is in its outer end suspended in a cutless self lubricating rubber bearing, but the stuffing box is to be lubricated. This should be done sparingly as overlubrication may result in that grease will reach the rubber in the bearing. During the running in period (first 10-20 hours), half a turn on the greaser should be made every second hour. The greaser is situated in the rear end of the engine compartment. The stuffing box may be examined by lifting the floor boards in the aft cabin. During the running in period the stuffing box must be checked against overheating. Maximum temperature is 70°. A slight dripping is normal when the engine is running. The box can be tightened by loosening the stop nut and turning the box half a turn. After tightening the box should be lubricated a few times and checked for overheating.

The cooling water intake is located on port side in the engine room. In the intake line a water strainer is fitted. The strainer should be checked regularly.

### Vacuum valve

In the cooling water line is a vacuum valve fitted to prevent water from entering the engine by suction after it has been stopped. This is placed in the engine room on the port side forward. Twice each season the vacuum valve should be opened and cleaned in fresh water.

1. Loosen the complete valve from its fixture and invert it.
2. Loosen the cap, check and clean the membrane and refit in opposit order. If the membrane is damaged it must be replaced.

NOTE! Check carefully that the membrane is correctly located when reassembling. Do not overtighten.

### Setting of ideling RPM

As most engines the MD 21 has specific critical speeds, where the engine comes in vibrations. These RPM:s should be avoided.

One critical speed is 800-900 RPM. From 650 which is the lowest permitted RPM to 800, the vibrations are considerable but not critical. To avoid this, the ideling RPM may be set at 1000 RPM, provided that the boat is not fitted with a folding propeller, which must be manoeuvred at lowest possible RPM.

### Fuel tanks and lines

As illustrated there are two fuel tanks. One, the main tank, containing about 220 litres (about 49 inp gall or 58 US gall) is built in below the engine intergral with the hull. The second is a reserve tank in stainless steel below the port side sofa in the main cabin. This tank contains about 120 l (26 inp gall or 29 US gall). The contents of this tank can be piped into the main tank by opening the valve situated under the rear end of the sofa.

In the main tank is a tankmeter with gauge in the instrument panel. Do not run the tank dry as the fuel system has to be vented before the engine is started if air has entered the suction pipes.

There are suction pipes, one for the engine and one for the optional heater. There is also a third suction pipe for a test pump from the lowest point of the tank with which eventual sludge and condensation water can be pumped out. The pump is situated in the engine compartment. With this pump the fuel should be tested regularly to avoid water reaching the filters and the fuel injection pump. If this happens, the pump can be seriously damaged.

### Hose clamps, important checkpoint

Some time after delivery and then at least annually all hose connections should be checked for leaks and tightness. If the hose cannot be twisted by hand and no leaks are apparent, the hose clamps should not be further tightened, as this will only damage the hose or the treads. Almost all hose clamps are in stainless steel and will not rust.

### Electric wiring

The electric circuits are divided in one for the engine and one for lightning and general purpose. One 115 AH battery serves the engine and two 115 AH are for the other circuit. The batteries are automatically charged together but the engine starting battery cannot be drained by lights or refrigerator and will always be practically fully charged. The warning in the Volvo Penta Instruction book not to turn the main switches off while running the motor is not valid for this boat, as the alternator is permanently connected to the batteries. Wiring diagrams are included.

If by mistake the two general purpose batteries have been totally drained, difficulties may arise to get the alternator to charge. If this happens, which is indicated by the amp. red light not going out, this is helped if the two circuits are connected for a moment by a jumper or a tool (at the back of the main switches).

### Optional second alternator

If a second 75 amp. alternator is fitted, this is charging the two light/general purpose batteries and the standard alternator is charging the starting battery. The wiring is shown by dotted lines on the diagram.

### Heating (optional)

The Webasto diesel burning air heater is mounted on the SB bulkhead in the engine room. The exhaust is led through a fitting on the outside of SB bluestripe. Fresh air is taken by duct from the outer charttable.

The starting of the heater is automatic and electronically programmed as is the stopping. The switch is flipped to "heat" for operation and to neutral for stop. Position "vent" is not normally used. The distribution of the warm air is controlled by push pull knobs moving flap valves in the ducting. One control knob on bulkhead above the sink in the galley controls the distribution forward or aft, two others above the sofas the outlets on the main cabin.

The thermostat at the navigating desk can be used to control the temperature but the frequent stopping and starting of the unit will put a heavier load on the batteries and discolouring by soot around the exhaust.

#### Engine room blower

For use when the main engine is not running, there is an electric blower in the engine compartment. This blower is normally only used if the heater has been running for a long period or after stopping the main engine after a long run.

#### Bilgepump

There is one manually operated bilgepump situated in the sail locker.

#### Watertank and FW system

The FW tank and lines are shown on attached diagram. The FW tank is built as an integral part of the GRP hull. The curved tanktop is provided with three manholes for cleaning out. The automatic pressure water system is doubled up with footpumps. The electric FW pump is situated in the engine compartment and will start automatically when the pressure in the tap lines drops.

Also situated in the engine compartment is a carbon filter and an air chamber. The filter charge may be boiled to clean if a replacement is not available. To remove the filter charge the FW pump is switched off at the instrument panel and the pressure is released by pressing the button on top of the filter house. The bowl is unscrewed to remove the filter inset. The FW system can be operated without the inset by simply replacing the bowl without fitting the inset and starting up again.

After the air chamber (black cylinder), which levels out pulsations in the pressure from the pump, the line branches off to different taps and to the water heater that is built in under the floor in the sail locker. The main valve on the hot water system is also situated under the floor in the sail locker on the engine room bulkhead.

The water heater is operating from the cooling system of the main engine. After the engine is started it will only take a quarter of an hour before hot water is available. The insulation will keep the water hot overnight.

When leaving the boat the automatic FW pump should be switched off at the instrument panel. If the pump runs and stops without any tap is open, this indicates a leak somewhere.

To drain the system, see chapter "Winterizing".

### Wheel steering

The wheel steering system should be examined carefully annually and the sheaves, the chain and the wire lightly oiled with motor oil. The bearings on the wheel shaft are greased every second year. The wire should be replaced at the sign of a broken strand. The tension of the wires is set up at the rudder quadrant.

### Toilets

A dependable marine toilet is fitted in the toilet room.

The double acting pump is operated with the black handle at the same time flushing with seawater and emptying the bowl. The flushing action is controlled by the small lever below the pump handle. This lever should be in the "dry bowl" position when the toilet is not used. The outlet valve and the valve to the optional holdingtank are also kept closed at sea or when the boat is left.

NOTE: Any foreign objects can block the toilet

### Holdingtanks

For European waters the boat can be equipped with a small holdingtank that can be emptied in open sea by opening the bottom valve. The valve to the tank should always be shut except when pumping in or dumping out to prevent back flow into the toilet bowl.

### Bottled gas

As standards for bottled gas vary in different countries, the NR 38 is delivered without such bottles and reduction valve for the propane gas stove. Stowage for two 6 kg (12 lbs) gas bottles is provided in a separate ventilated compartment in the forepeak. A one piece 8 mm od copper pipe is drawn to a shut off valve at the gas range. The reduction valve should be for 30 mbar (300 mm water head). The connections should be periodically tested for leaks with soap water.



The standard UPO cooker is provided with a flame failure device that shuts off the gas supply in the event of a flame blow out. To light either burner the device is bypassed by pressing in the control knob turning to igniting position and holding in for 10-15 seconds. To ignite the oven the small separate button must be pressed.

#### Optional anchor winch

The boat can as an optional extra be equipped with a manual or an electric anchor winch. In both alternatives the anchor is dropped by releasing the clutch controlled by the star nut on the outside of the chain gipsy. This is turned against the clock with the handle bar supplied with the anchor winch to disengage. The clutch can be used to brake the chain.

For hauling, the clutch is first engaged and then the winch is operated either by inserting the handle bar at the rope gipsy side or on the electric winch by pushing the switch. The chain will stow itself in the bottom of the chain locker but the hatch is best kept open to make it possible to observe if the chain is building up to the mouth of the chain pipe.

## MAINTENANCE

### Gelcoat - Repair of Damages

The outer, colored coating of a fiberglass boat is called the Gelcoat. This is a plain coating, which protects the fiberglass hull and at the same time gives the boat an elegant and easy-to-care exterior. The thickness of the Gelcoat is approximately  $1/32$  -  $1/64$  of an inch and thus considerably thicker than a normal color coat. It is completely homogenous and has the same hardness right through. This is why it is often possible to remove bad scratches through grinding or polishing without having to apply any new plastic. It is not difficult either to repair deeper scratches or damages. Any air bubbles, scratches or ruptures that may occur in this outer coating does not mean that water can penetrate the laminate.

#### 1) Maintenance of plastic surfaces in good condition

The plastic surfaces of the boat should be kept clean and spotless for a nice appearance. Use regular detergents and water but avoid detergents which may cause scratches. Do not use detergents containing ammonia as they may damage fittings, plexiglass, etc. Detergents and solutions should be thoroughly rinsed off. Should the shiny surfaces get dull they can be polished either by hand, using a polishing agent, or by using a low revolution machine. There are several special polishing agents for fiberglass boats on the market.

Waxing is not normally required, but can do no harm. When waxing notice that the wax has to be worked well. Do not wax any surfaces with pattern, which will make them slippery.

#### 2) Repair of superficial scratches, etc.

Scratches in the gelcoating may often look deeper than they really are and as the scratched surface is different in color than the shiny one, you may think that the colored coating has been penetrated. For reasonably deep scratches use water sanding. Start with a coarse paper and little by little change down to a fine paper (No 800). Rub the surface after sanding, i.e. use polish and an abrasive on the surface as well as on the surrounding undamaged surfaces.

#### 3) Repair of deep scratches and scuffings

If the gelcoating has been damaged and completely removed, the repair is done as follows. Get Gelcoat in the proper color (see Information Sheet) and a hardener from a fiberglass manufacturer or the yard. The damage is then cleaned with the edge of a knife and covered with masking tape very closely on both sides of the hole. Mix the Gelcoat and the hardener (approximately 2% of the hardener). The temperature in the working area should be between 60-80 F.

Use a generous amount of the gelcoat to fill in the damaged spot and immediately place a piece of tape over the same to avoid the gelcoat from running. After the plastic has hardened, grind off the surplus and polish the surface.

Scaffings under the waterline are filled with putty epoxy (Interpad) and then painted with a 2-component primer, e.g. International Poly Ground.

Larger scaffings, in case the boat has hit bottom hard, have to be cleaned from crushed fiberglass through grinding and are then repaired with fiberglass mat and plastic before final putting (repair sets are available on the market).

#### Maintenance of Wood - Interior

The interior surfaces of mahogany are thoroughly treated with a synthetic laquer and even after many years of use do not normally need any other maintenance than a cleaning. Should a surface, however, be damaged to the extent that it would be necessary to re-varnish same, the whole damaged surface has to be sanded and then varnished with a mat laquer (International Lagolac or similar). Most of the minor damages are taken care of with a little bit of oil. Interior teak, mouldings, etc. can be oiled once in a while with teak oil.

#### Exterior Wood

The exterior wood is made of genuine teak and is not dependent on either laquer or oil for its protection. It is thus a matter of taste whether the teak should be varnished or be left untreated. It is our opinion that the varnished teak has a better appearance and that it sets off a better contrast against the other plastic surfaces. But of course a certain maintenance is required to keep it up from wear and tear. Decks and seats should never be varnished. When the teak is treated at the yard, we use a synthetic varnish with a oil-phenolic resin glue base. Varnish with a pure oil base is not suitable and a 2-component varnish should not be used on top of the old varnish. Untreated teak is scrubbed thoroughly at the same time as the cleaning of the fiberglass surfaces and will after some time take on a silvergrey shade. In our experience, the use of teak oil on the exterior may cause bad looking surfaces, which are difficult to maintain. Therefore we advise against oiling. It is most important that the maintenance treatment of varnished surfaces is made in time. When you can see that it is needed, it is too late. It is a good piece of advice to re-varnish already after one or two months in the first season and then at least once every year. When you re-varnish, the surrounding fiberglass surfaces must be well protected from streaks or drips of varnish, which otherwise leave spots which are difficult to remove. Should you happen to spill some varnish, be careful to remove same immediately as, even if it is practically translucent from the start, it will from the sun turn yellow very quickly on the fiberglass surfaces.

### Spars

The masts and booms are made in anodised light alloy. Under special circumstances light alloy is subject to electrolysis. For this reason no bronze or brass fittings should be attached directly to the spars. Also bigger fittings in stainless steel should be isolated from the light alloy with a plastic sheet. The spars must not be stowed away with salt deposits for winter. Hosing down with fresh water, drying and waxing will prevent damage in store. Rigging should be removed or isolated if wrapped round the spar.

### Winches

All winches should be greased at least once a year, preferably before the winter layup. When the locking ring at the top of a winch is removed the drum can be lifted for inspection cleaning and greasing.

### Carpets

The quality of the carpets permits cleaning by scrubbing and hosing down with fresh water on deck.

## Winterizing in areas subject to freezing temperatures

### Engine

The engine is prepared according to the instruction book. When your boat is delivered from the yard antifreeze has been added to the freshwater coolant.

### Toilet and holdingtank

A washing detergent is pumped through and the system is flushed with freshwater. The drainplug under the pumpmanifold is removed. The WC discharge seacock should be dismantled and greased with waterproof grease. This prevents the valve to gradually stuck later. If the discharge seacock gets stuck with the boat in the water it can be withdrawn and greased. Some water will enter but one hand on the valve house will prevent flooding the boat.

### The bilge

When the boat is on dry land the drain plugs from the bilge-well are unscrewed and the bilge is cleaned and flushed.

### Batteries

If the batteries are well charged they can be left in the boat provided that the cables are disconnected and the terminals greased. If a battery charger is permanently fitted in the boat (optional equipment), the operation of this must be blocked if the battery terminals are disconnected.

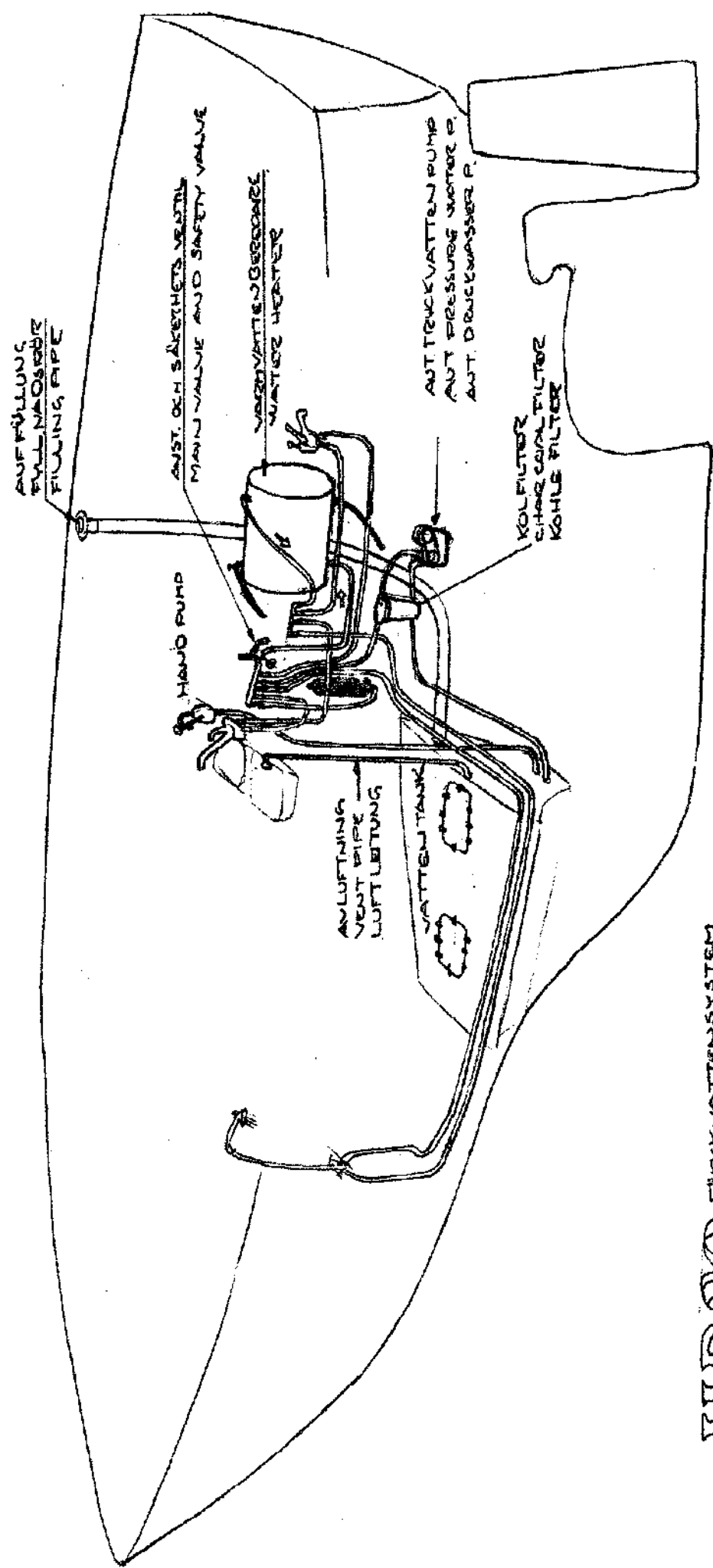

**HR38**  
 FRESH WATER SYSTEM  
 FRESH WATER SYSTEM  
 FRESH WATER SYSTEM

① Sugledning för motor  
Saugleitung der Motor  
Suction pipe

② Returlledning fr. motor  
Returledning  
Return

③ Tankventilation  
Entlüftung  
Air pipes

④ Bränslepåfyllning  
Deckverschraubung  
Fuel filling

⑤ Dykrör för ev. värmeanläggning  
Für Heizung  
Suction pipe for evt. heater

⑥ Bränslemätare (visar 0 vid ca 60 lit)  
Geber für Vorratsanzeiger (0=60 l)  
Tankgauge (start showing at abt 60 lt)

⑦ Slampump  
Sumpf-Pumpe  
Test pump

⑧ Plugg för manuell pejling  
Peil-Stab  
Sounding plug

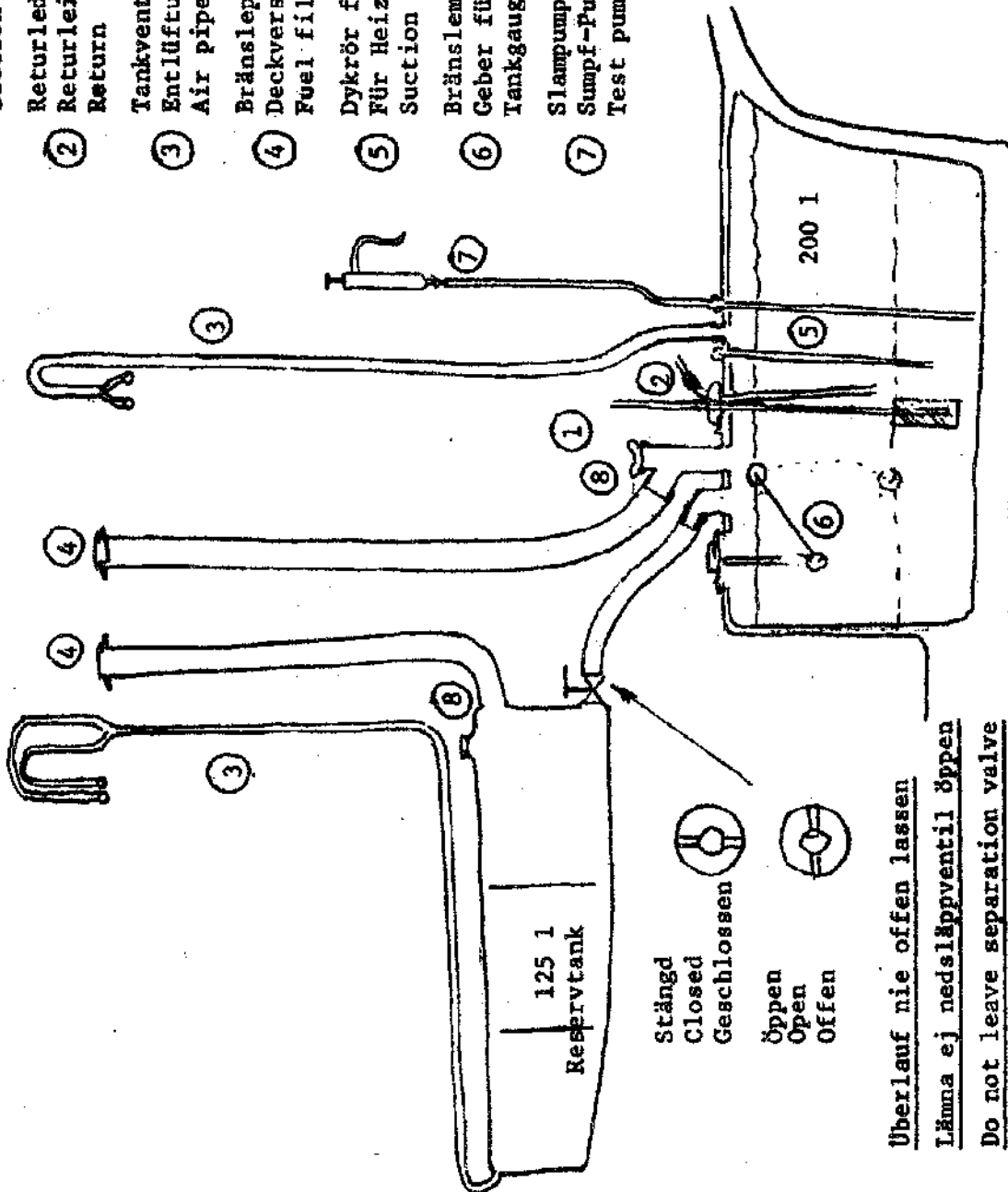

Überlauf nie offen lassen  
Lämma ej nedsläppventil öppen  
Do not leave separation valve  
open

Huvudtank  
Maintank  
Haupttank

HIR 338

Treibstofftanks  
Bränsletankar  
Fuel tanks

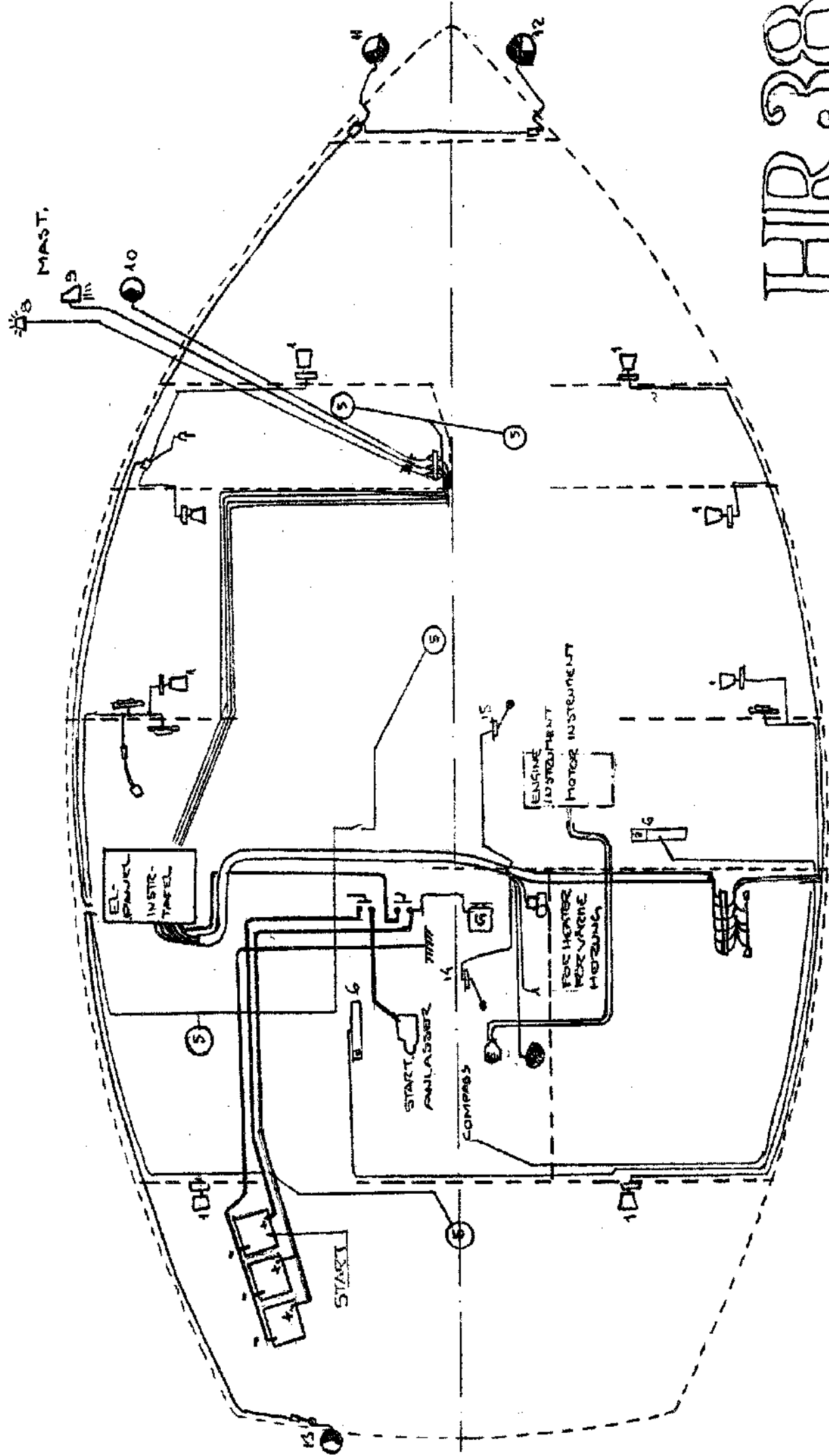

# HIR 38

NR SE LISTA  
 NO SEE LIST  
 NR SIEHE LISTE



	typ type Typ	Ampi
1. Kojlampa Elidus Berth lamp Kojenlampe		
2. Kojlampa Hella Berh lamp Kojenlampe	"	2JA 001 330 011
3. Kartlampa Hella Navigation lamp Kartentischlampe	"	2AB 003 112 001
4. Kartlampa Hella Navigation lamp Kartentischlampe	"	2AB 003 112 011
5. Taklampa Hella Ceiling lamp Deckenbeleuchtung	"	2JA 001 354 001
6. Lysrör Hella Fluorescent lamp Leuchtröhre	"	2JA 002 565 001
7. Uttag	"	
a) Socket-outlet Steckdose		
b) Uttag Hella Socket-outlet Steckdose	"	8JB 001 946 02
8. Ankarlanterna Hella Anchor light Ankerlicht	"	2LT 002 492 001
9. Däcksbelysning Plastimo Decklampe Deckbeleuchtung		
10. Topplanterna Hella Toplight Topplaterne	"	2LT 002 386 002
11. BB lanterna Hella Port lamp Bb Laterne	"	2LT 002 386 062
12. SB lanterna Hella Starboard lamp Stb Laterne	"	2LT 002 386 052
13. Akterlanterna Hella Stern light Achterlicht	"	2LT 002 386 022
14. Bränslegivare VDO Fuelmeter Brennstoffmesser	"	226 081 009 001
15. Vattengivare VDO Water meter Wassermesser	"	226 828 001 001

# HR 38

Switch board rear side

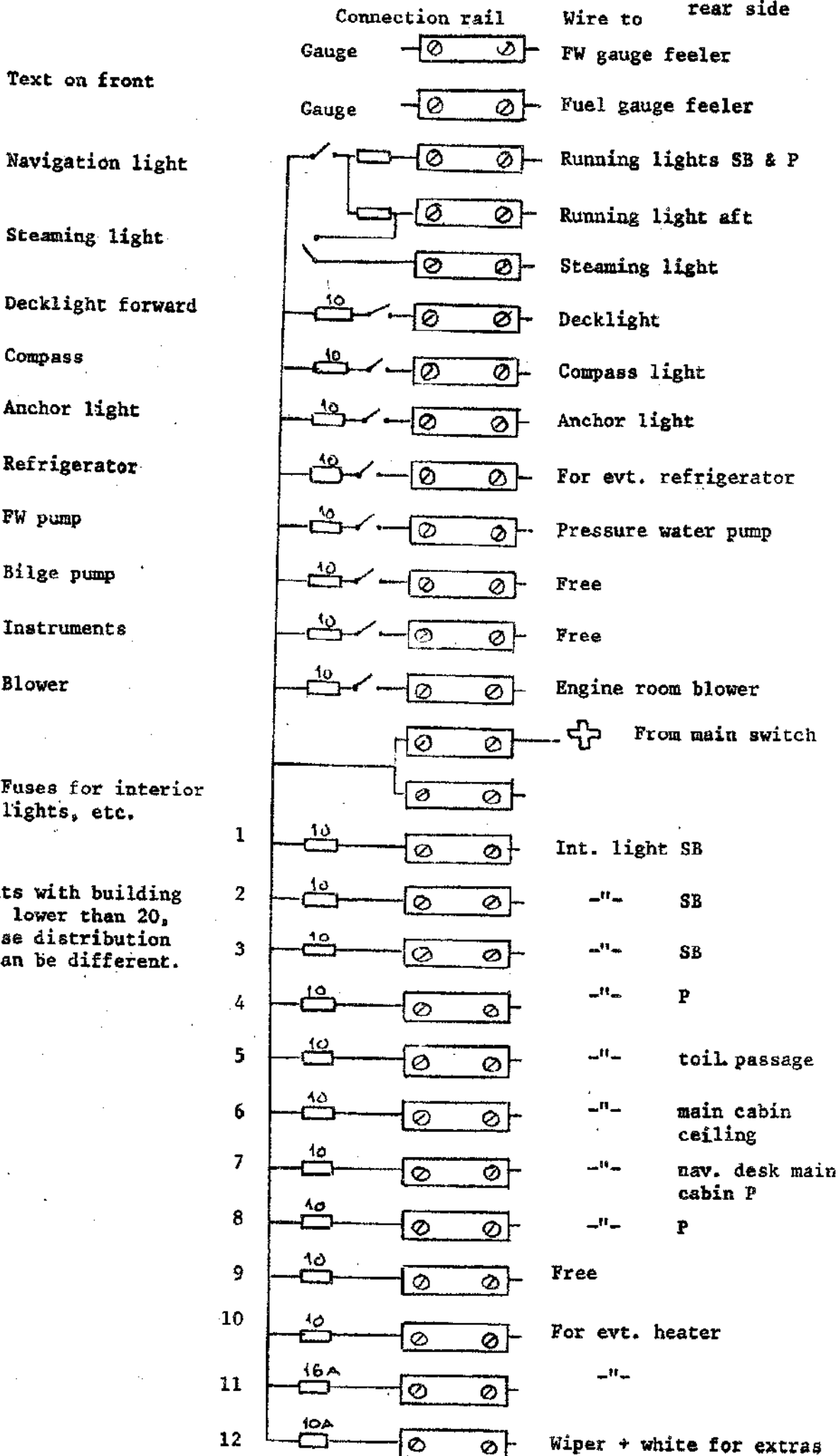

Text on front

Navigation light

Steaming light

Decklight forward

Compass

Anchor light

Refrigerator

FW pump

Bilge pump

Instruments

Blower

Fuses for interior lights, etc.

On boats with building number lower than 20, the fuse distribution 1-12 can be different.

Webasto Nr 15

Kabelstock från eltavla  
Zu Instrumenttafel  
From the main switch board

10 black

evt. 4,5 black

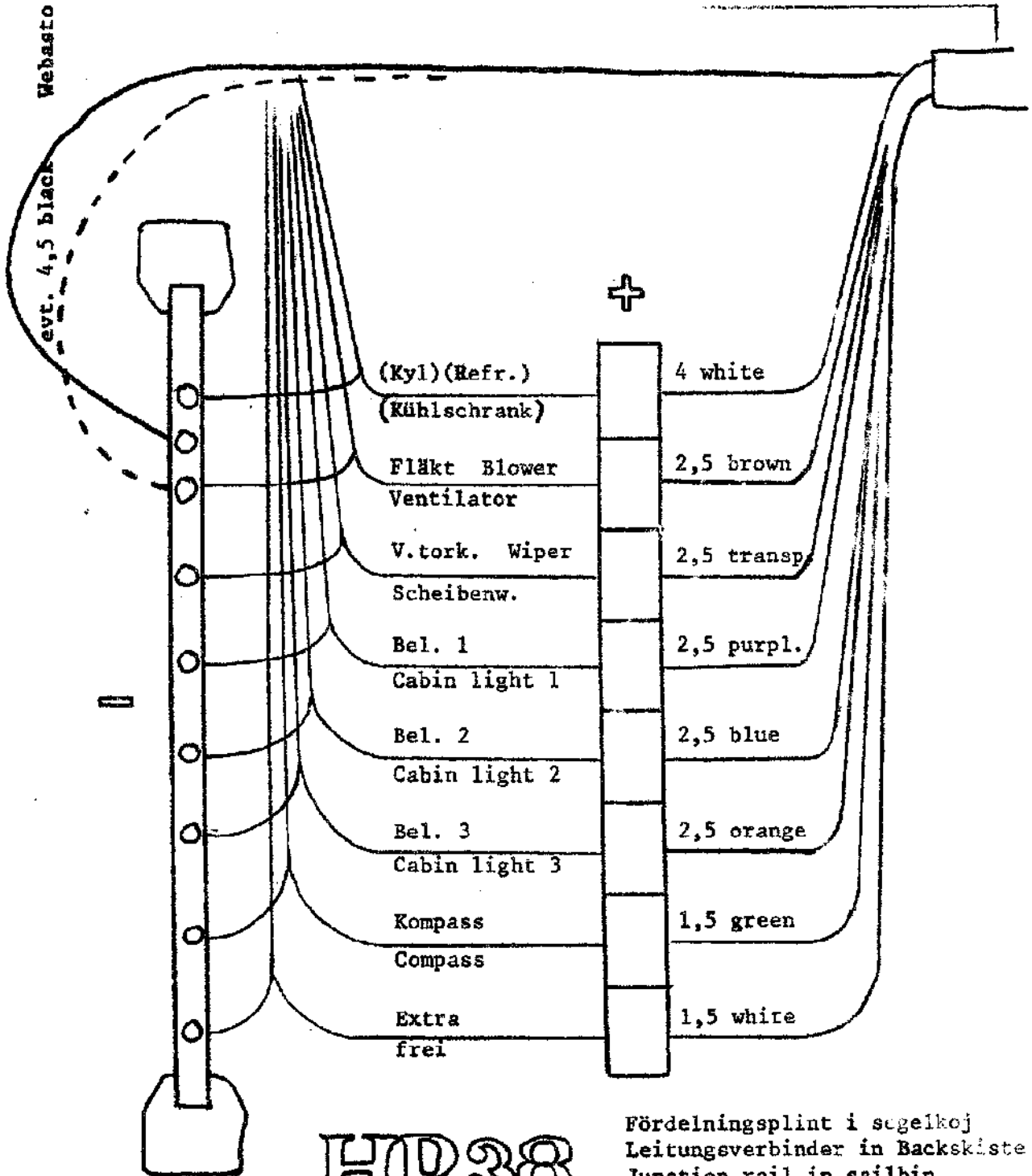

HR38

Fördelningsplint i segelkoj  
Leitungsverbinder in Backskiste  
Junction rail in sailbin

## COMPONENTS INSTRUMENT PANEL

- 1 KEY SWITCH
- 2 SWITCH FOR INSTR. LIGHT
- 3 TEMPERATURE GAUGE
- 4 WARNING OIL PRESSURE
- 5 TACHOMETER
- 6 WARN. LIGHT CHARGING
- 7 CONTR. LIGHT GLOW PLUG
- 8 SWITCH F. EXTRA EQUIP.
- 9 EV. WARN. LIGHT FOR OPTIONAL EXTRA ALTERNATOR.
- 10 DIODE FOR FIELD OF EXTRA ALTERN.

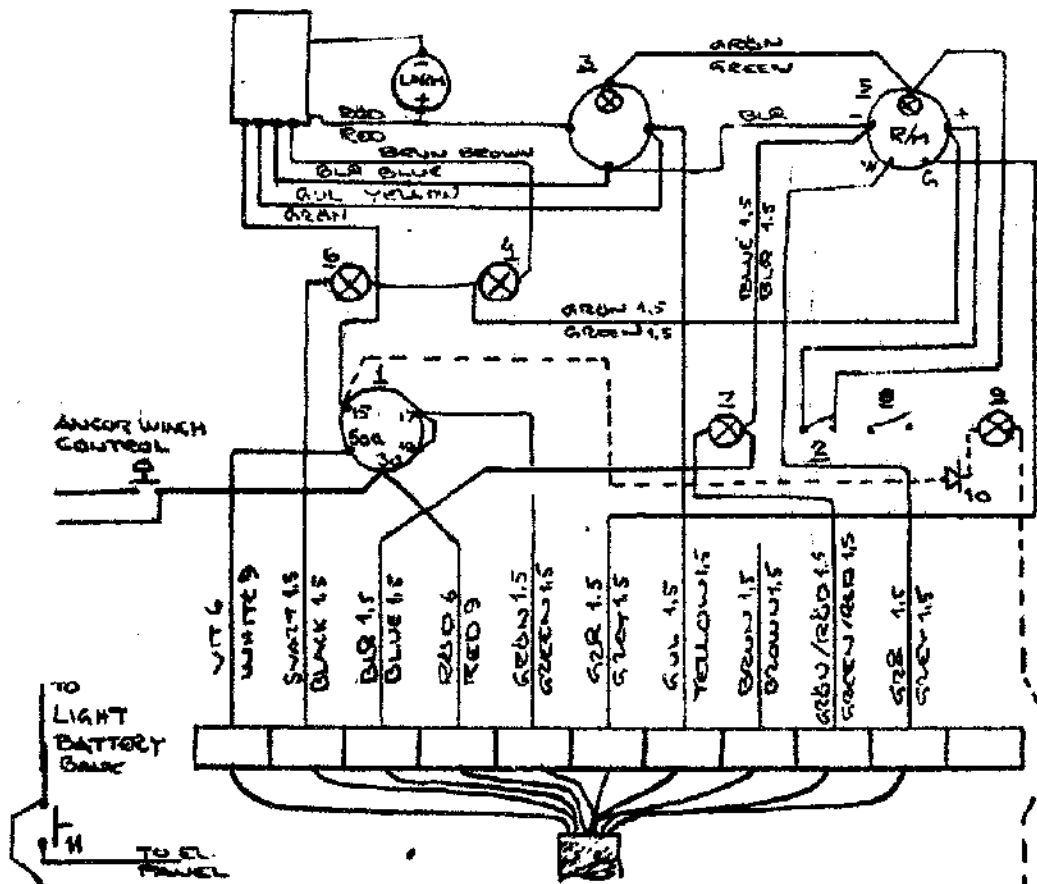

## COMPONENTS ENGINE

- 11 MASTER SWITCH
- 12 STARTER MOTOR
- 13 CHARGING REGUL.
- 14 ALTERNATOR
- 15 OIL PRESSURE SEND.
- 16 TACHOMETER SENS.
- 17 TEMPERATURE SENS.
- 18 GLOW PLUGS
- 19 CONNECTOR
- 20 RELAY FOR GLOW PL.
- 21 FUSE
- 22 CONTROL RESISTANCE
- 23 JOINT

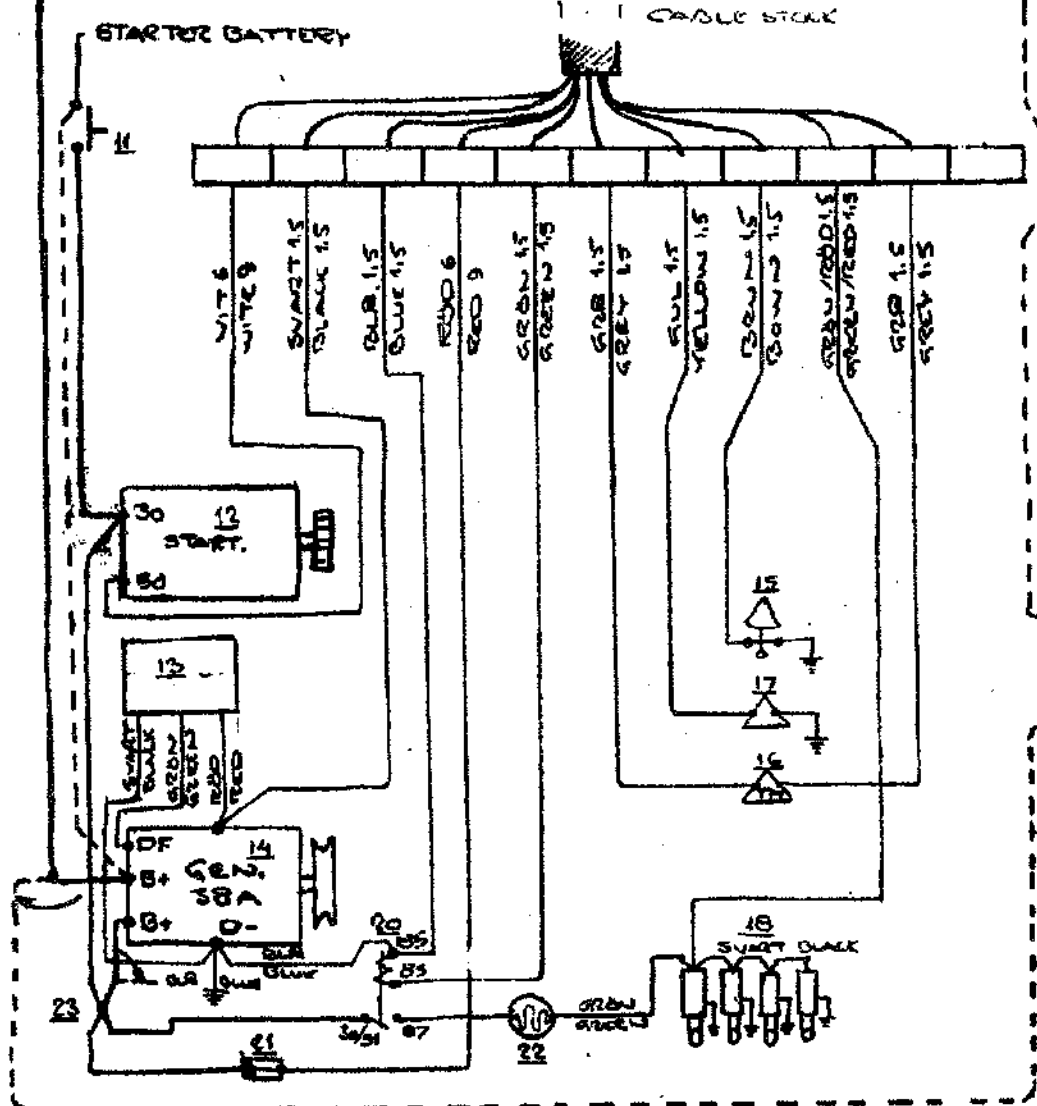

## EV. EXTRA GENERATOR

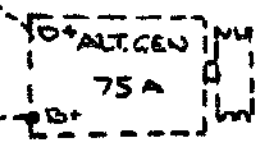

WIRING WITH EXTRA GENERATOR