

Owner's Manual Supplement 210 Sundeck

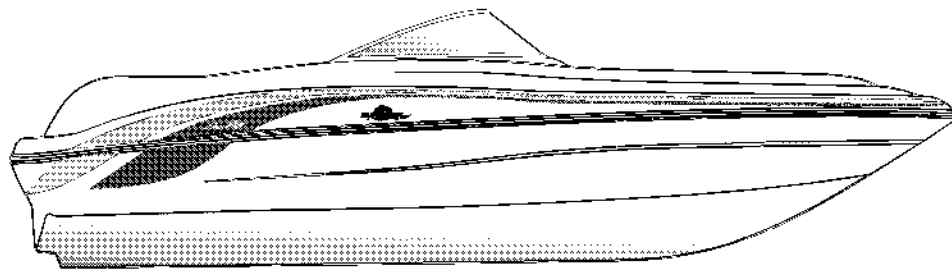

Sea Ray®

Sea Ray® • Owner's Manual Supplement • 210 Sundeck • MRP #970400
Printed in the U.S.A. September 1997. Revised August 1998, Revised May 2002, ©Sea Ray Boats, Inc.
Sea Ray Boats, Inc. 2600 Sea Ray Blvd., Knoxville, TN 37914.
For information call 1-800-SRBOATS, or fax 1-314-213-7878 Domestic/International
Internet address: <http://www.searay.com>
Note: Not all accessories shown in pictures or described herein are standard equipment or even available as options.
Options and features are subject to change without notice.

INTRODUCTION & TABLE OF CONTENTS

This owner's manual supplement has been written to provide additional specific information about your boat and should be read carefully. Keep this booklet with the owner's manual in the owner's manual packet.

The owner's manual packet has been compiled to help you to operate your craft with safety and pleasure. It contains details of the craft, the equipment supplied or fitted, its systems and information on its operation and maintenance. Please read the information in it carefully, and familiarize yourself with the craft before using it.

If this is your first craft, or you are changing to a type of craft you are not familiar with, for your own comforts and safety, please ensure that you obtain handling and operating experience before "assuming command" of the craft. Your dealer or yacht club will be pleased to advise you of local sea schools, or competent instructors.

PLEASE KEEP THIS OWNER'S MANUAL PACKET IN A SECURE PLACE, AND HAND IT OVER TO THE NEW OWNER WHEN YOU SELL THE CRAFT.

Warranty Information	4	Battery	11
Construction Standards	4	Ventilation System / Bilge Blower	12
Hull Identification Number	4	Steering System	12
Servicing Your Sea Ray®	4	Fire Extinguishing System	12
Owner's Manual Packet Contents	5-6	Fire Extinguisher Discharge Port	12
General Arrangements & Dimensions	7	Anchoring	13
Seating Plan Options	7	Anchoring Arrangement	13
Supplemental General Information	8	Life Saving Equipment (PFD)	13
Bilge Pumping System	8	Boat Storage	13
Propulsion System	8	Troubleshooting	13
Propellers	8	List of Reference Manuals and Drawings	14
Head System (Optional)	9	Repair and Parts Facilities	14
Requirements for Vessel Operators	9	Docking / Lifting / Trailering	14
Fuel System	9-10	Bilge Layout	15
Fuel Vent & Fuel Fill	10	Dash Layout	16
Water System	10	Location Of Through-Hull Fittings	17
Exhaust System	11	Wire Harness Installation	18
Engine Cooling System	11	Wiring Schematics	19-20
Electrical Installations	11	International Homologations	21

(This book contains 21 pages.)



Information in this publication is based upon the latest product specifications available at printing. Sea Ray® Boats, Inc. reserves the right to make changes at any time, without notice, in the colors, equipment, specifications, materials and prices of all models, or to discontinue models. Should changes in production models be made, Sea Ray® is not obligated to make similar changes or modifications to models sold prior to the date of such changes.

The following are registered trademarks of the Brunswick Corporation: Sea Ray®, The SR Wave Logo.

WARRANTY INFORMATION

Sea Ray's® warranty is better than ever. Find the warranty information card in your owner's manual packet for complete details. If for some reason the card is missing, contact your Sea Ray dealer for a new one.

CONSTRUCTION STANDARDS

Sea Ray's® commitment - Excellence by Design - has enabled us to create a superior craft providing you with comfort, performance, safety and dependability. All our boats comply with the safety standards set by the United States Coast Guard and are designed, engineered and manufactured in accordance with applicable recommendations and guidelines of the American Boat and Yacht Council (ABYC) certified by the National Marine Manufacturers Association (NMMA).

HULL IDENTIFICATION NUMBER (HIN)

The "Hull Identification Number," located on the starboard side of the transom, is the most important identifying factor and must be included in all correspondence and orders. Failure to include it only creates delays. Also of vital importance are the engine serial numbers and part numbers when writing about or ordering parts for your engine. Refer to the engine owner's manual for locations.

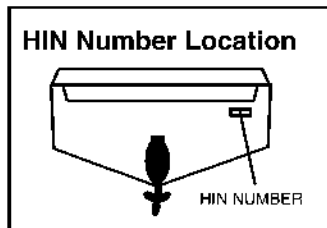

SERVICING YOUR SEA RAY®

When your boat needs service beyond regular maintenance it should be taken to an authorized Sea Ray® dealer.

To find a dealer in your area call:
1-800-SRBOATS.
Fax: 1-314-213-7878
Domestic/International

If a problem is not handled to your satisfaction:

1. Discuss any warranty-related problems directly with the service manager of the dealership or your sales person. Give the dealer an opportunity to help the service department resolve the matter for you.
2. If a problem arises that has not been resolved to your satisfaction by your dealer, contact Sea Ray® Boats at 1-800-SRBOATS and the appropriate customer service department information will be provided for you.

OWNER'S MANUAL PACKET CONTENTS

	Sea Ray® Owner's Manual	Sea Ray® Owner's Manual Supplement	Sea Ray® Specification Sheet	Sea Ray® Parts Manual	Engine Operator's Manual	Original Equipment Manuals	Owner's Packet Insert
Accident Reporting	X				X	X	X
Alarms					X		
AM/FM Cassette Stereo						X	
Anchoring	X	X	X				X
Battery	X	X			X	X	
Bilge Layout				X			
Bilge Blower	X	X		X		X	
Bilge Pump	X	X		X		X	
Canvas	X			X		X	
Capacity Plate	X			X			
Carbon Monoxide	X						
Certifications		X	X				
Cleaning	X					X	
Cockpit				X			
Communication Equipment	X					X	
Compass	X					X	
Console				X			
Construction Standards		X					
Controls	X			X		X	
Decals				X			
Depth Finder						X	
Dimensions		X	X				
Drains (Through-Hull Fittings)		X					
Education	X						
Electrical System	X	X		X			
Electrolysis	X						
Emergency Engine Shutdown	X				X		
Emergency Procedures	X						
Engine					X		
Environmental Considerations	X						
Equipment:							
• Recommended	X						
• Required	X						X
• Standard			X				
• Optional			X				
Fire	X						
Fire Suppression Equipment	X	X				X	X
Flame Arrestor					X		X
Flooding, Swamping	X						
Fuel System	X			X	X		
Gauges	X	X		X			
Gear Shift	X			X	X		
Global Positioning System (GPS)							
Graphics				X			
Head System	X	X	X	X			
Homologations (International)			X				
Hotlines	X					X	X
Identification Numbers	X	X					
Ignition	X				X		
Ignition Protection	X				X		

OWNER'S MANUAL PACKET CONTENTS

	Sea Ray® Owner's Manual	Sea Ray® Owner's Manual Supplement	Sea Ray® Specification Sheet	Sea Ray® Parts Manual	Engine Operator's Manual	Original Equipment Manuals	Owner's Packet Insert
Impaired Operation	X						X
Instrument Use & Operation	X					X	
Layout		X	X	X			
Lifesaving Equipment	X						X
Lifting	X	X					
Lightning Protection	X						
Lights	X	X		X			
Load Capacity	X	X					
Maintenance	X				X	X	
Maneuvering	X						X
Monitors						X	
Nautical Terms	X						
Navigation	X						X
Operation	X						
Optional Systems			X			X	
Personal Flotation Devices (PFD's)	X					X	X
Power Capacity	X						
Powertrain	X				X		
Propeller	X	X					
Propulsion					X		
Registration	X						X
Safety	X					X	X
Seating		X					
Seaworthiness Inspection	X						
Service Schedule					X	X	
Spare Parts				X			
Specifications		X	X				
Stability	X						
Start-In-Gear Protection	X						
Steering	X	X		X			
Symbols	X	X					
Switches		X					
Tank Capacities		X	X				
Throttle	X				X		
Through-Hull Fittings		X					
Troubleshooting	X				X	X	
Upholstery	X			X			
Ventilation	X	X		X			
Warning Labels	X			X			
Warranty		X					X

To replace any material from the Owner's Manual Packet, contact your Sea Ray® dealer.

GENERAL ARRANGEMENTS & DIMENSIONS

PROFILE
(FIG. 7.1)

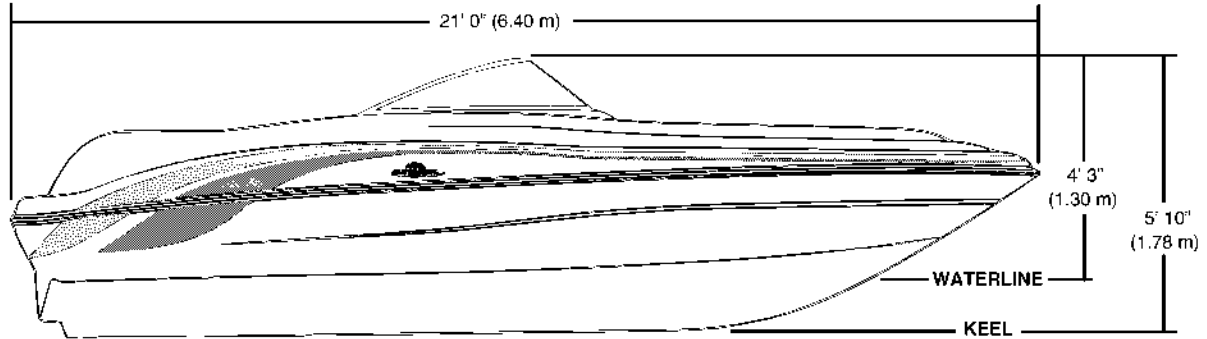

210 SUNDECK — SPECIFICATIONS

Overall Length	21' 0" (6.40 m)
Beam	8' 6" (2.59 m)
Draft (Stern Drive Down)	37" (94 cm)
Draft (Stern Drive Up)	17 3/4" (45.1 cm)
Dry Weight (Lbs.)	3,500 (1,588 kg)
Fuel Capacity (Gallons) ...	50 gal (189.3 liters)
Usable Fuel (Gallons) ...	47.25 gal (179.8 liters)
Water Capacity	10 gal (37.9 liters)
Dead Rise	21°
System Voltage	12 VDC
Battery Capacity	Dealer Installed

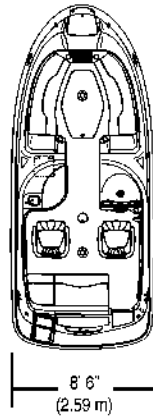

(FIG. 7.2)

HEIGHT DIMENSIONS

Waterline To Top Of Windshield	4' 3" (1.30 m)
Keel To Top Of Windshield	5' 10" (1.78 m)

INTERIOR SEATING PLANS

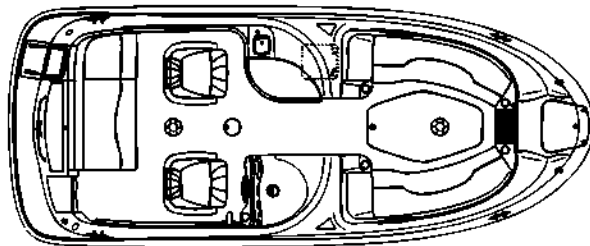

STANDARD SEATING PLAN

Swivel Bucket Helm Seat w/Slider, Aft Bench Seating w/Removable Jump Seat & Storage Below, Molded Bow Rider Seating w/Fiberglass Storage (fig. 7.3)

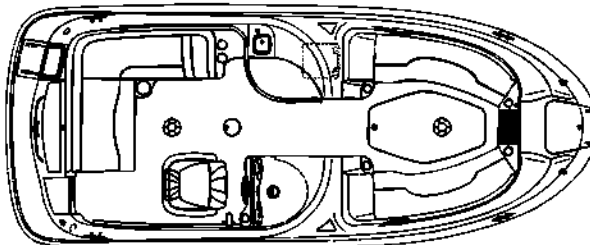

OPTIONAL SEATING PLAN

Port L-Shaped Lounger Seat, Swivel Bucket Seat w/Slider & Flip-Up Thigh-Rise Bolster (fig. 7.4)

SUPPLEMENTAL GENERAL INFORMATION

BILGE PUMPING SYSTEM

Your boat is equipped with an automatic electric bilge pumping system consisting of a bilge pump with float switch. The pump is protected by a 4 amp fuse on a fuse block located under the helm (see fig. 16.1).

The bilge pump is equipped with a switch on the dash with a "MANUAL" and "AUTO" position. When the switch is in the "MANUAL" position, the pump will run continuously. When in the "AUTO" position, the pump is activated when there is enough water in the bilge to raise the float switch to its highest position; and deactivated when the water recedes. **The pump should NOT be left in the "MANUAL" mode unless the bilge is being pumped out for servicing.**

Frequently inspect the area under the pumps and float switches to ensure they are free from debris and gummy bilge oil.

REFER TO THE OWNER'S MANUAL AND OWNER'S PACKET FOR INSTRUCTIONS AND WARRANTY INFORMATION.

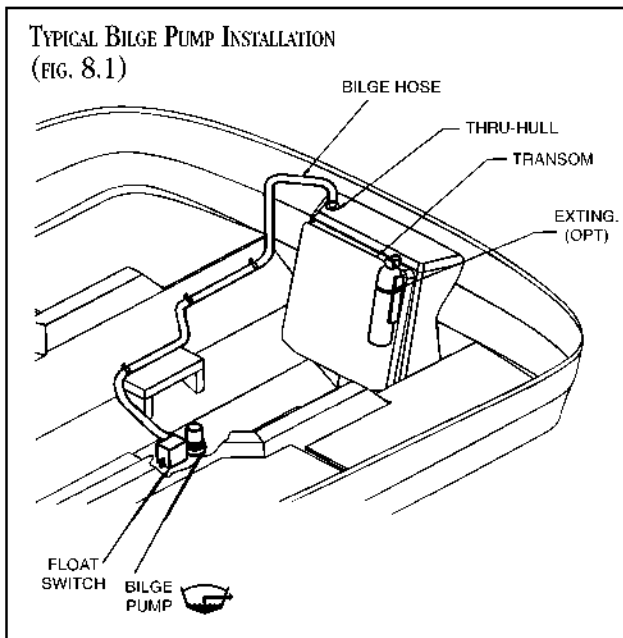

PROPULSION SYSTEM

The 210 Sundeck is equipped with a stern drive type propulsion system also known as an inboard-outboard engine. This type of propulsion system has the engine secured to the hull's stringers at the aft end of the hull and covered by an engine box. The drive unit, also called the lower unit because it hangs below the hull, is the part of the propulsion system that attaches to the outside of the hull or transom. The drive unit pivots to steer the boat.

REFER TO THE OWNER'S MANUAL AND ENGINE OWNER'S MANUAL FOR OPERATING INSTRUCTIONS AND WARRANTY INFORMATION.

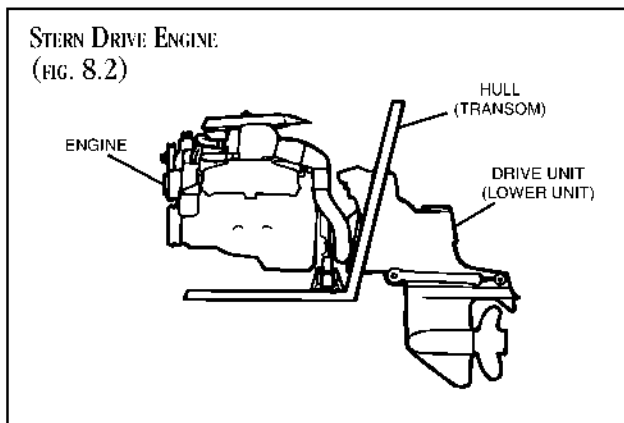

PROPELLERS

Your Sea Ray® has been equipped with a propeller which our tests have shown to be the best suited for general use under normal conditions and load. In some situations you may wish to change propellers to give your boat slightly different performance characteristics. In general, changing to a lower pitch propeller will increase acceleration and load-pulling ability, but with a slight decrease in top speed. Conversely, moving to a higher pitch propeller will attain higher top speed with a light load, but will sacrifice acceleration and power. Your particular requirements should be discussed with your Sea Ray® dealer.

Under no circumstances use a propeller which allows the engine to operate at higher than recommended RPM.

SUPPLEMENTAL GENERAL INFORMATION

HEAD SYSTEM (OPTIONAL)

There are two (2) optional head systems available for your Sea Ray® 210 Sundeck. The owner's manual packet in your boat contains information pertaining to your optional head system that should be carefully read.

REQUIREMENTS FOR VESSEL OPERATORS

The Environmental Protection Agency (EPA) standards state that in freshwater lakes, freshwater reservoirs or other freshwater impoundments whose inlets or outlets are such as to prevent the ingress or egress by vessel traffic subject to this regulation, or in rivers not capable of navigation by interstate vessel traffic subject to this regulation, marine sanitation devices certified by the U.S. Coast Guard installed on all vessels shall be designed and operated to prevent the overboard discharge of sewage, treated or untreated, or of any waste derived from sewage. The EPA standards further state that this shall not be construed to prohibit the carriage of Coast Guard-certified flow through treatment devices which have been secured so as to prevent such discharges. They also state that the waters where a Coast Guard-certified marine sanitation device permitting discharge is allowed include coastal waters and estuaries, the Great Lakes and interconnecting waterways, freshwater lakes and impoundments accessible through locks, and other flowing waters that are navigable interstate by vessels subject to this regulation (40 CFB 140.3).

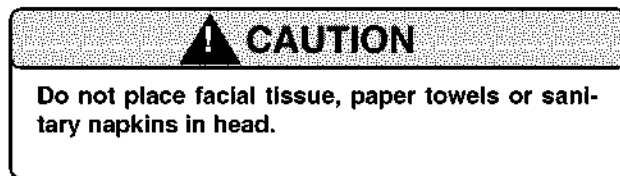

PORTABLE SELF-CONTAINED HEAD (OPTION)

The portable self-contained unit has two individual holding tanks. The top tank is fitted with a hand pump and holds fresh water and chemicals. The bottom tank is for holding waste material.

REFER TO OWNER'S PACKET FOR INSTRUCTIONS AND WARRANTY INFORMATION.

PUMP-OUT HEAD (OPTION)

The optional portable head with dockside pump-out is the same head as described above except the holding tank has a dockside pump-out hose attached. The hose leads to a waste plate on the deck. To empty holding tank, the services of a dockside pump-out station will be needed. Follow instructions at the station and make sure pump-out station hose is inserted into the deck plate marked "WASTE."

REFER TO OWNER'S PACKET FOR INSTRUCTIONS AND WARRANTY INFORMATION.

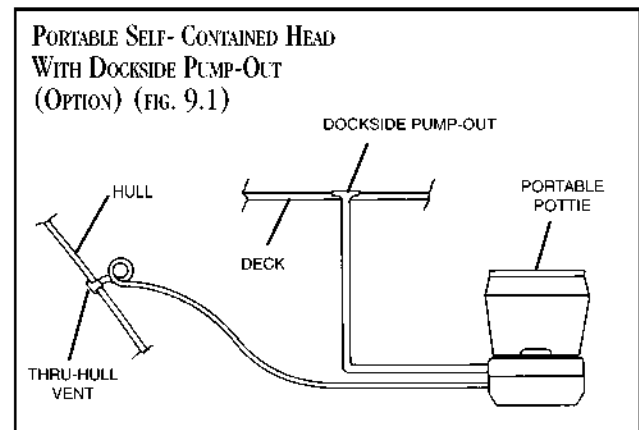

FUEL SYSTEM

Located in the owner's packet is the *Sea Ray® Operational and Safety Manual* that contains important fueling information. Take time to read all the fuel related information in the owner's packet.

The 210 SD standard gasoline fuel system consists of a 50 gallon (189.3 liter) fuel tank, fuel tank vent, an anti-siphon valve, engine fuel supply line and fuel fill (see fig. 10.1).

SUPPLEMENTAL GENERAL INFORMATION

The gasoline engine fuel pick-up at the fuel tank has an anti-siphon valve to prevent fuel from siphoning out in the event of fuel line failure.

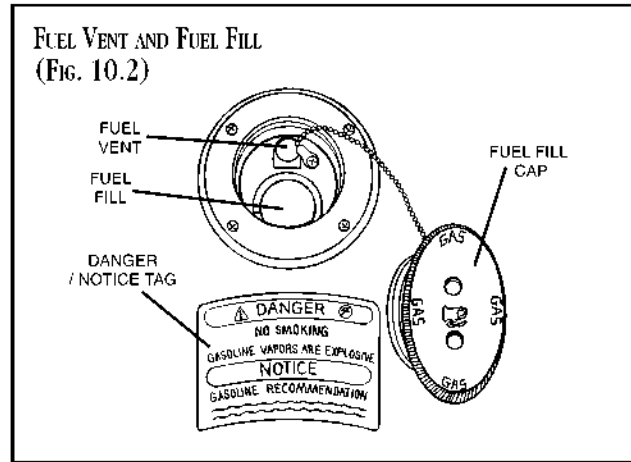
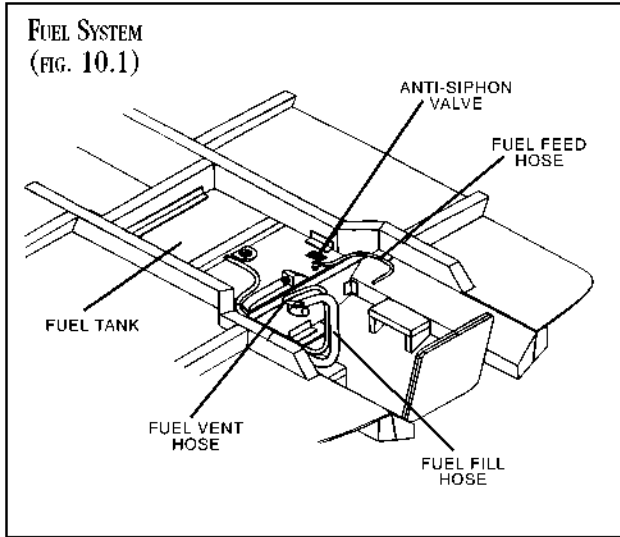

CAUTION

Never start an engine until you are certain that fuel fumes are not present in engine compartment or elsewhere in the boat.

The fuel tank vent serves as a pressure/vacuum release and safety overflow. The fuel vent is located at the fuel fill under the fuel cap. Periodically check the vent to assure that it is not clogged.

WATER SYSTEM

The 210 SD water system consists of a 10 gallon (37.9L) water tank, water pump and strainer, transom shower, cockpit sink, sprayer and optional bow shower.

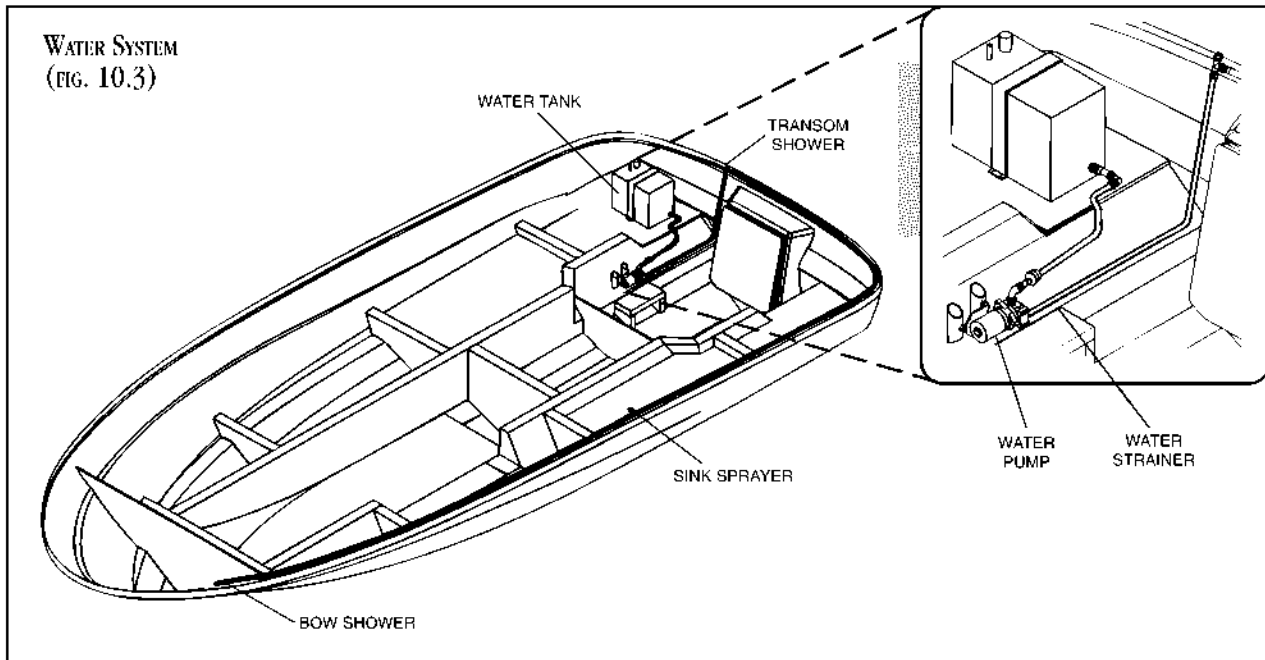

SUPPLEMENTAL GENERAL INFORMATION

EXHAUST SYSTEM

The 210 SD exhaust system is an integral part of the propulsion system.

REFER TO THE ENGINE OWNER'S MANUAL FOR INSTRUCTIONS AND WARRANTY INFORMATION.

ENGINE COOLING SYSTEM

The engine cooling system is an integral part of the propulsion system.

REFER TO THE ENGINE OWNER'S MANUAL FOR INSTRUCTIONS AND WARRANTY INFORMATION.

ELECTRICAL INSTALLATIONS

This owner's manual supplement contains electrical schematics for your boat. These electrical schematics were generated by technicians at the engineering division for technical reference and service technicians. Sea Ray® does not recommend that you attempt to work on the boat's electrical system yourself, instead we recommend that you take your boat to your authorized Sea Ray® dealer for service. Sea Ray® reserves the right to change or update the electrical system on any model at any time without notice to the consumer and is NOT obligated to make any updates to units built prior to changes.

BATTERY

Refer to the *Sea Ray® Operational and Safety Manual* for battery disconnect and maintenance.

ALWAYS DISCONNECT BATTERY CABLES BEFORE DOING ANY WORK ON THE ENGINE'S ELECTRICAL SYSTEM OR ALTERNATOR WIRING TO PREVENT ARCING OR DAMAGE TO THE ALTERNATOR.

⚠ CAUTION

While the engine is running the battery terminal clamps must not be loosened or detached nor should the battery switch(es) be turned off, otherwise the alternator and other electronic units will be damaged.

⚠ DANGER

- Never use an open flame in the battery storage area.
- Avoid striking sparks near the battery.
- A battery will explode if a flame or spark ignites the free hydrogen given off during charging.

NOTE: The bilge pump and stereo memory CANNOT be turned OFF with the battery switch. The entire remaining DC system CAN be turned OFF with the battery switch.

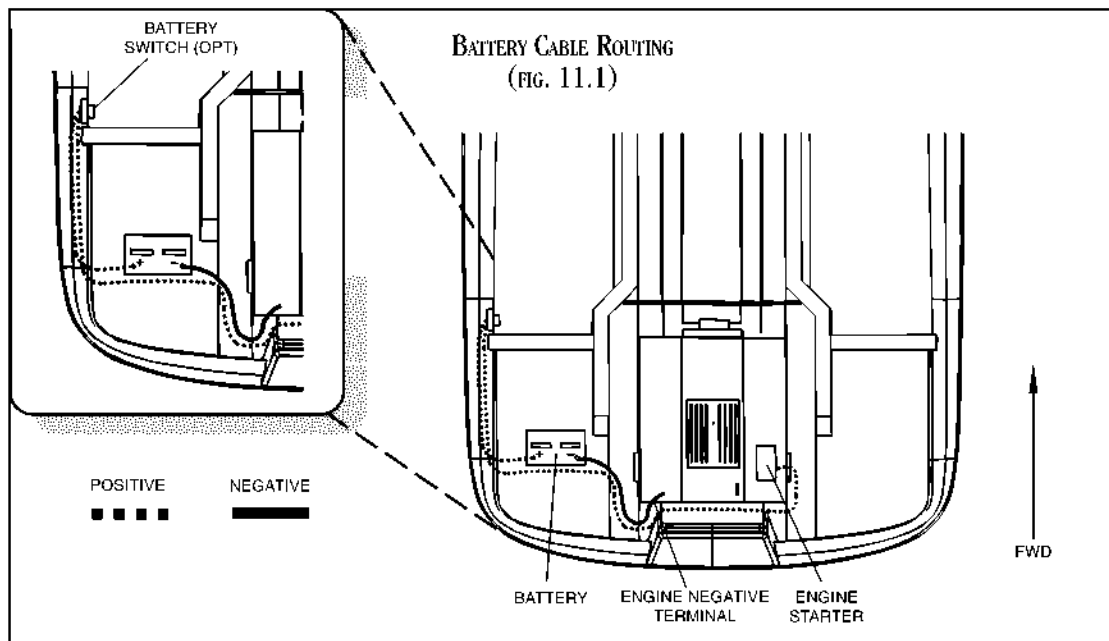

SUPPLEMENTAL GENERAL INFORMATION

VENTILATION SYSTEM/BILGE BLOWER

Sea Ray® Sport Boats are equipped with an electric bilge blower to remove fumes from the engine compartment and provide ventilation through the deck vents before starting the engine and when operating below cruising speeds. The bilge blower is located inside the port side of the transom.

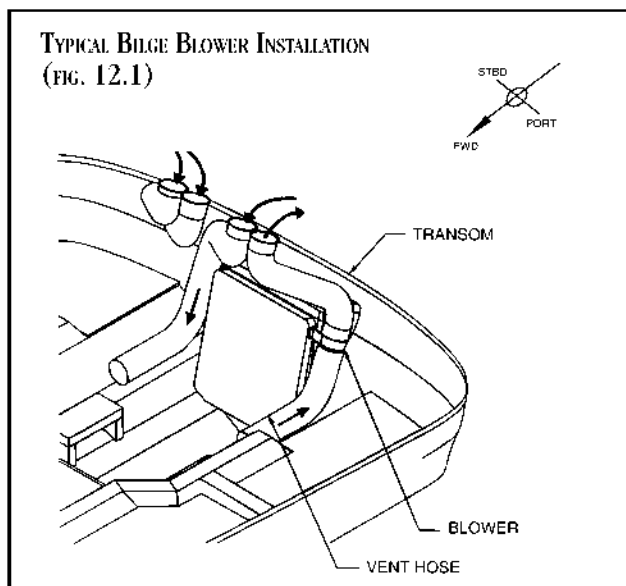

REFER TO OWNER'S MANUAL AND OWNER'S PACKET FOR OPERATING INSTRUCTIONS AND SAFETY PRECAUTIONS.

STEERING SYSTEM

The 210 SD is equipped with a power steering system.

REFER TO THE ENGINE OWNER'S MANUAL IN THE OWNER'S PACKET FOR INSTRUCTIONS AND WARRANTY INFORMATION.

FIRE EXTINGUISHING SYSTEM

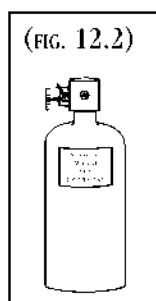

The 210 SD is offered with the optional automatic fire extinguishing system. If your boat is not equipped with this option you must carry an approved fire extinguisher.

Following are United States Coast Guard (USCG) requirements and American Boat & Yacht Council (ABYC) recommendations

for boats not equipped with the automatic fire extinguishing system option for open boats over 16 feet (4.9 meters) but less than 26 feet (7.9 meters).

<u>Standard</u>	<u>Boat</u>	<u>Qty.</u>	<u>*Qty.</u>	<u>Type</u>
USCG	210 SD	1	0	B1
ABYC	210 SD	2	0	B1

*Boats with approved fixed extinguishing system, (automatic fire extinguisher system).

Location: Outside engine compartment, steering position and cabin.

Note: To be ABYC compliant Sea-Ray Boats, Inc. follows ABYC construction standards and recommendations.

The automatic fire extinguisher system uses fire extinguishant and is installed in the bilge. In the event of a fire, the heat sensitive automatic head will release extinguishant flooding the area. The system indicator light is wired to the ignition and is turned ON when the ignition is turned ON. The system indicator light is located on the helm instrument panel. Under normal circumstances, when the ignition is ON the indicator light is lit. If the unit discharges, the light will go out.

WHEN ACTUATION OCCURS, IMMEDIATELY SHUT DOWN ALL ENGINES, POWERED VENTILATION, ELECTRICAL SYSTEMS AND EXTINGUISH ALL SMOKING MATERIALS. DO NOT OPEN THE ENGINE COMPARTMENT IMMEDIATELY!! THIS FEEDS OXYGEN TO THE FIRE, AND FLASHBACK COULD OCCUR.

Allow the extinguishant to "soak" the compartment for at least fifteen (15) minutes and for hot metals or fuels to cool before cautiously inspecting for cause of damage. Have portable extinguishers at hand and ready. Do not breathe fumes or vapors caused by the fire.

REFER TO THE OWNER'S MANUAL AND OWNER'S PACKET FOR INSTRUCTIONS AND WARRANTY INFORMATION.

SUPPLEMENTAL GENERAL INFORMATION

FIRE EXTINGUISHER DISCHARGE PORT

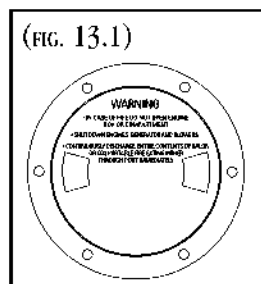

Inboard/Outboard sport boats not equipped with the automatic fire extinguisher option are equipped with a fire extinguisher discharge port. In the event of a fire, the access plate on the starboard side of the engine compartment can be removed to allow the operator to discharge a fire extinguisher into the engine compartment without having to open the engine box.

Do not open the engine compartment immediately! This feeds oxygen to the fire and flashback could occur.

⚠ WARNING

- In case of fire **DO NOT** open engine box or compartment.
- Shut down engine and blower.
- Continuously discharge entire contents of portable fire extinguisher through port immediately.

ANCHORING

To anchor, bring the bow into the wind or current and put the engine in neutral. When the vessel comes to a stop, lower, do not throw, the anchor over the bow. The anchor line should be 5 to 7 times the depth of water.

ANCHORING ARRANGEMENT

The 210 Sundeck is equipped with an anchor storage hatch with an anchor storage cradle inside. Stow the anchor in the cradle when not in use. Note: Before using the anchor be sure the anchor line is secured to the boat – to the bow eye or bow cleat.

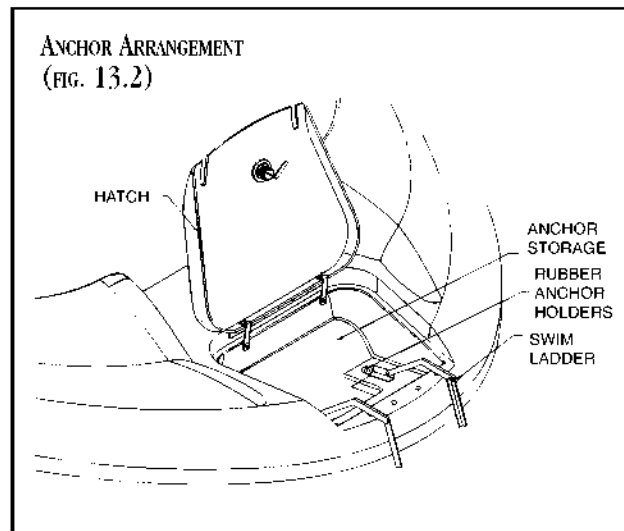

LIFE SAVING EQUIPMENT

(PERSONAL FLOTATION DEVICE (PFD))

STORAGE: The 210 SD offers storage under the bow cushions and floor storage.

OPERATION: Wear PFD according to manufacturer recommendations. See pamphlet *Federal Requirements And Safety Tips For Recreational Boats* in the owner's packet or get one from your dealer.

MAINTENANCE: Rinse with fresh water and let dry thoroughly. Do not store in a damp compartment. Avoid the possibility of mildew.

BOAT STORAGE

WET STORAGE PROCEDURES: Special care for boats that are moored: If permanently moored in salt water or fresh water, your boat will collect marine growth on its bottom. This will detract from the boat's beauty and greatly affect its performance. There are two methods of preventing this:

SUPPLEMENTAL GENERAL INFORMATION

- Periodically haul the boat out of the water and scrub the bottom with a bristle brush and a solution of soap and water.
- Paint the hull below the waterline with a good grade of antifouling paint. DO NOT paint the engine drive surfaces.

NOTE: There are EPA regulations regarding bottom paint application. Consult your marine paint dealer for proper application methods.

SECURITY CONSIDERATIONS: Be conscious of the security of your boat. Always remove the key from the ignition, store your boat in a secure place, put a lock on the trailer and if location permits chain your trailer to a pole or other permanently fixed object.

TROUBLESHOOTING

LIST OF REFERENCE MANUALS AND DRAWINGS

PERFORMANCE: Refer to the owner's manual.

ENGINE: Refer to the owner's manual and/or the engine manual.

ELECTRICAL: Refer to electrical section of the owner's manual and electrical schematics in this owner's manual supplement. Only a qualified marine electrical technician may service the boat's electrical system.

REPAIR AND PARTS FACILITIES

To find a Sea Ray® dealer in your area, call: Sea Ray® Customer Service: 1-800-SRBOATS
FAX: 1-314-213-7878
Domestic/International

To find repair and parts facilities for equipment installed on your boat, refer to the original equipment manuals (OEM's) found in the owner's manual packet.

DOCKING/LIFTING/TRAILERING

CLEATS: Cleats must not be used for lifting the boat, they are intended for mooring use only.

BOW AND STERN EYES: The bow eye should be used to haul the boat onto a trailer. The stern eyes should be used as tie down points for trailering the boat. The bow and stern eyes may be used for short term lifting of the boat such as for service. Long term lifting with the bow and stern eyes may cause stress on the fiberglass and gel coat.

For long term storage use flat, wide belt-type slings and spreaders long enough to keep pressure from gunwales. Do not place slings where they may lift on underwater fittings.

REFER TO THE OWNER'S MANUAL IN THE OWNER'S PACKET FOR INSTRUCTIONS.

BOW EYE & CLEATS
(FIG. 14.1)

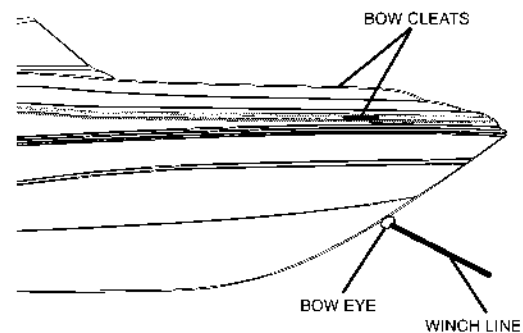

STERN EYES AND CLEATS
(FIG. 14.2)

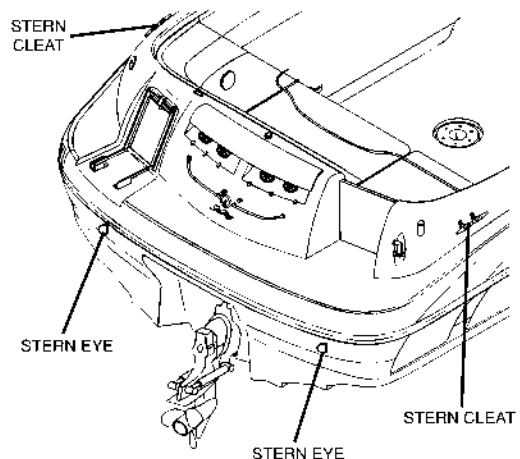

BILGE LAYOUT

(FIG. 15.1)

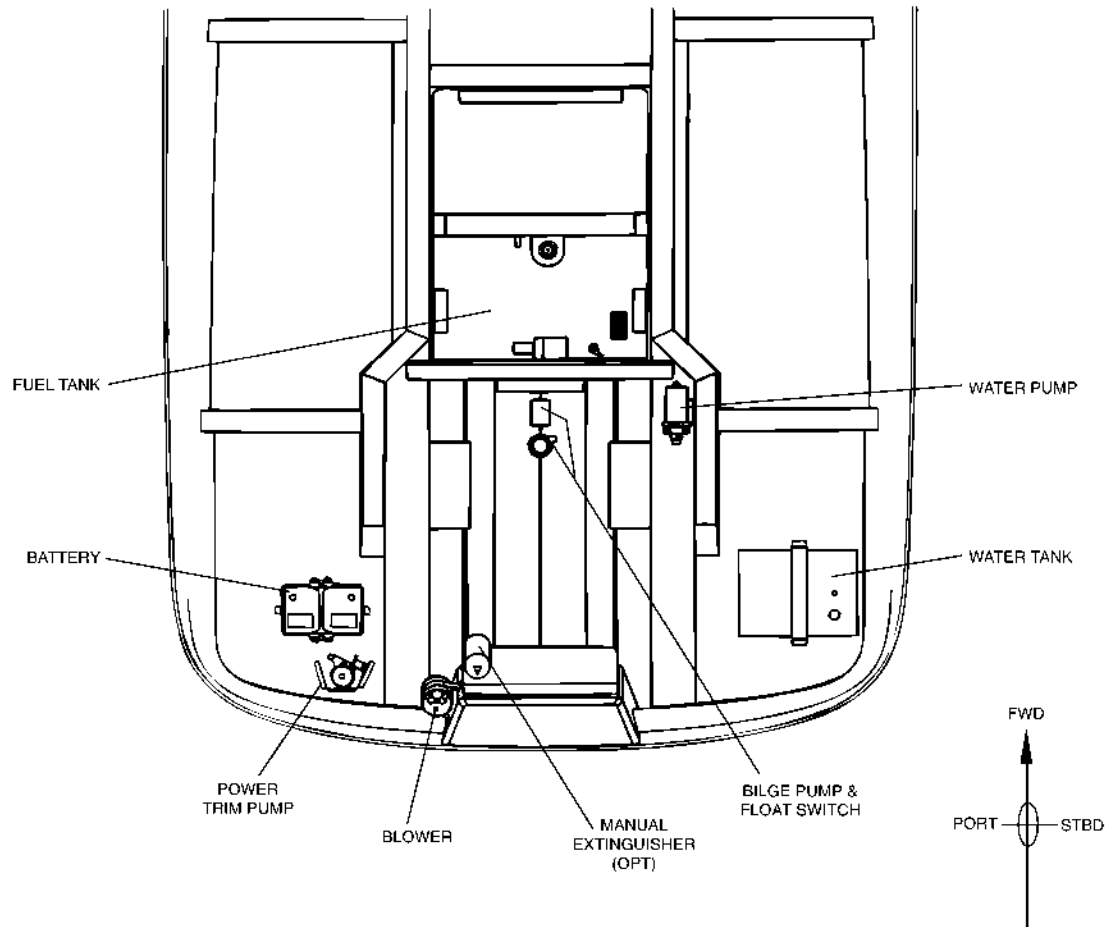

DASH LAYOUT

DASH
(FIG. 16.1)

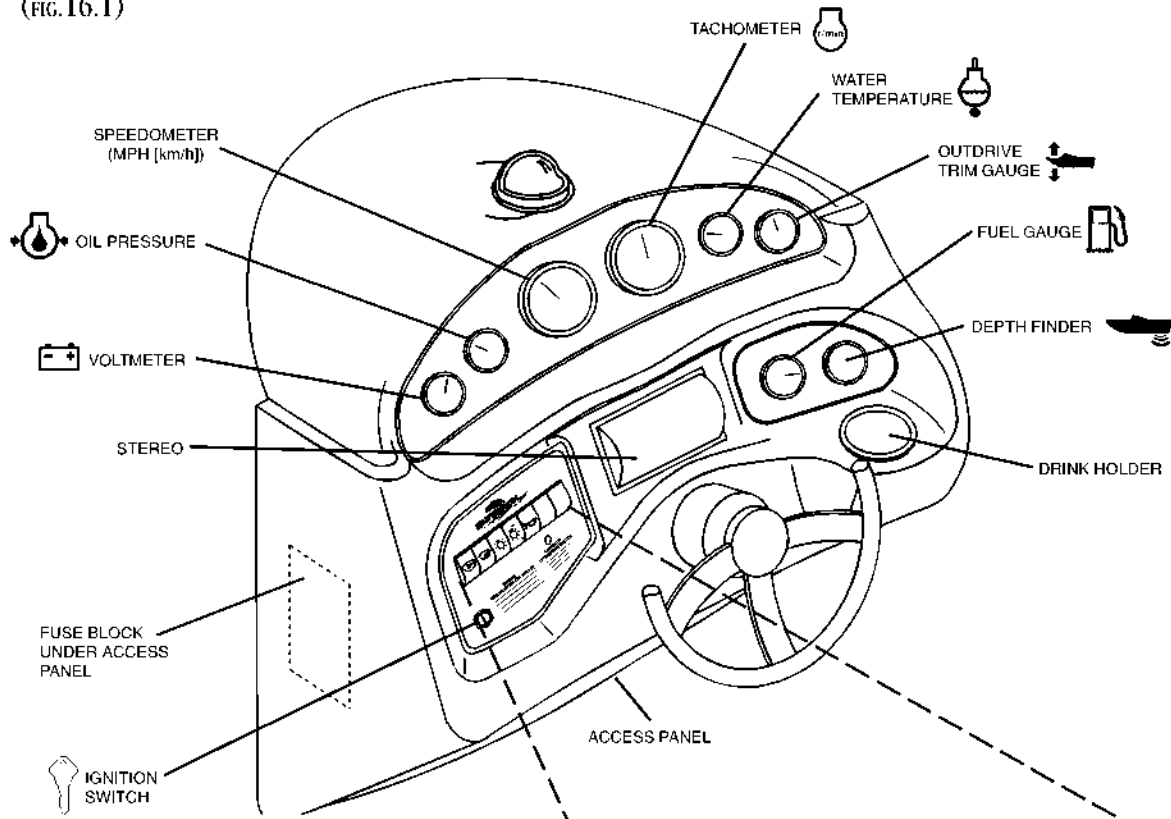

SWITCH PANEL
(FIG. 15.2)

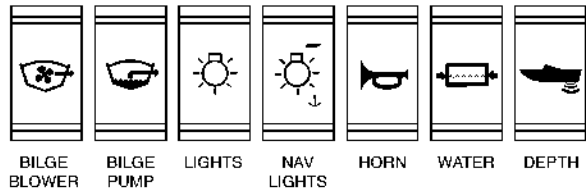

LOCATION OF THROUGH-HULL FITTINGS

STARBOARD SIDE
(FIG. 17.1)

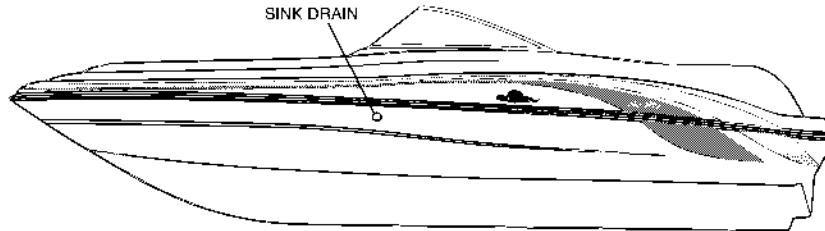

PORT SIDE
(FIG. 17.2)

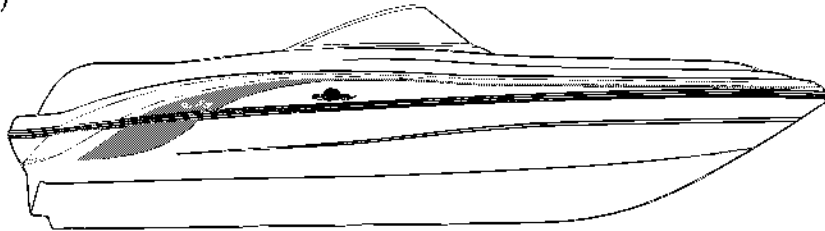

BILGE
(FIG. 17.3)

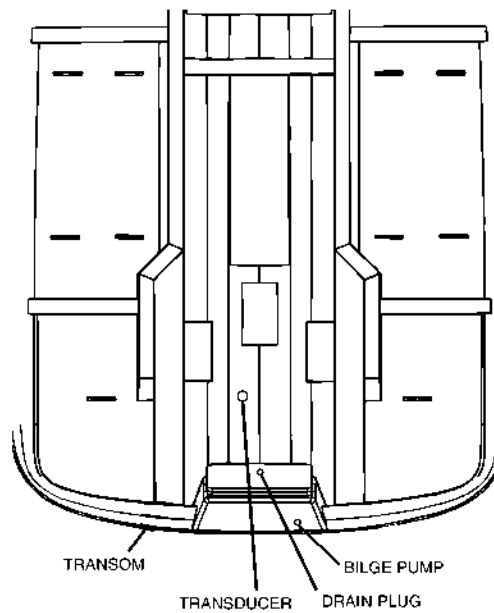

WIRE HARNESS INSTALLATION

(FIG. 18.1)

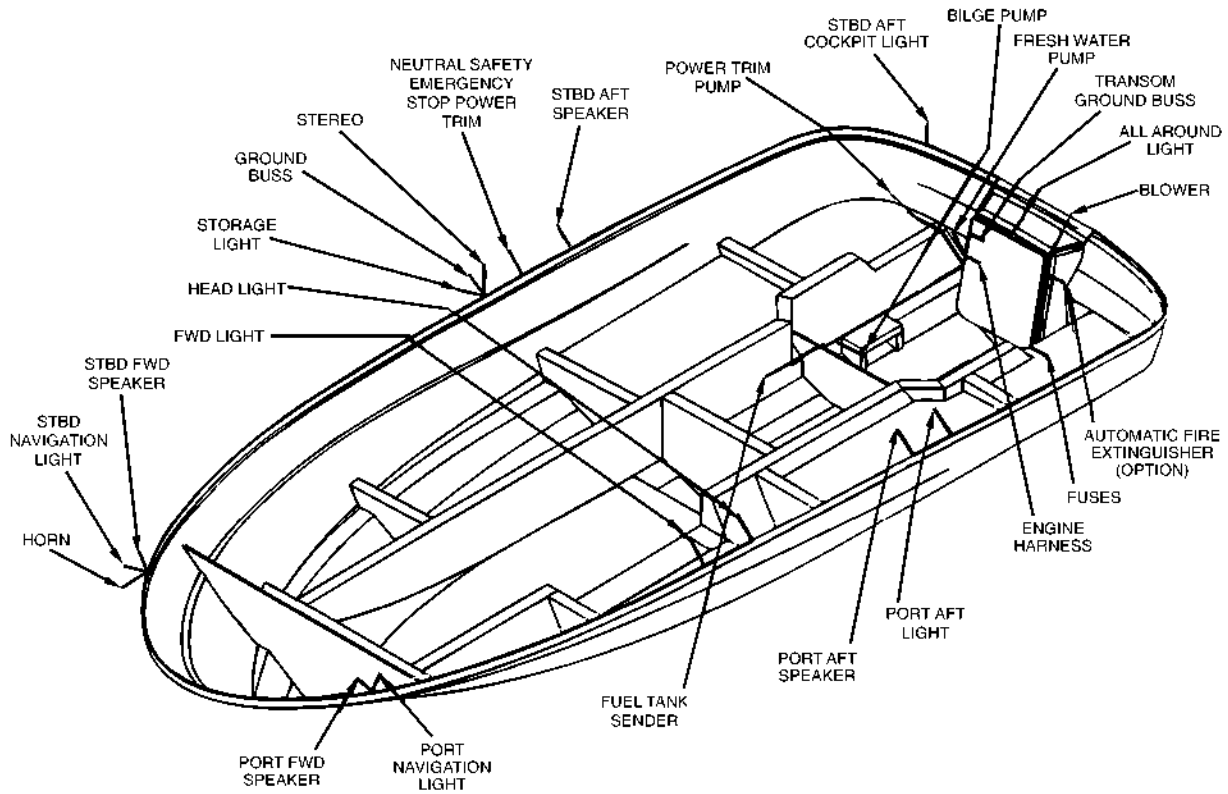

WIRING SCHEMATICS

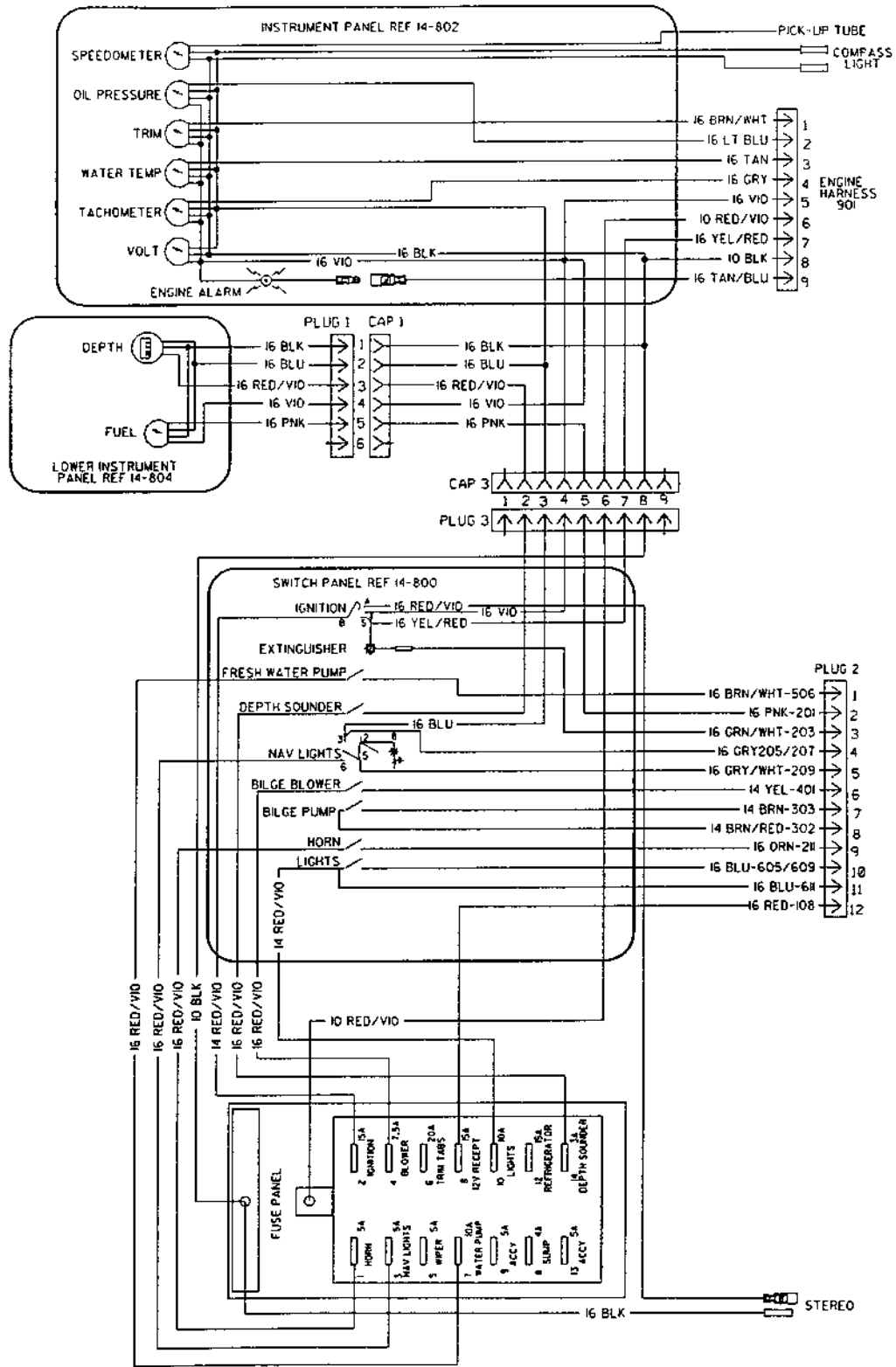

WIRING SCHEMATICS

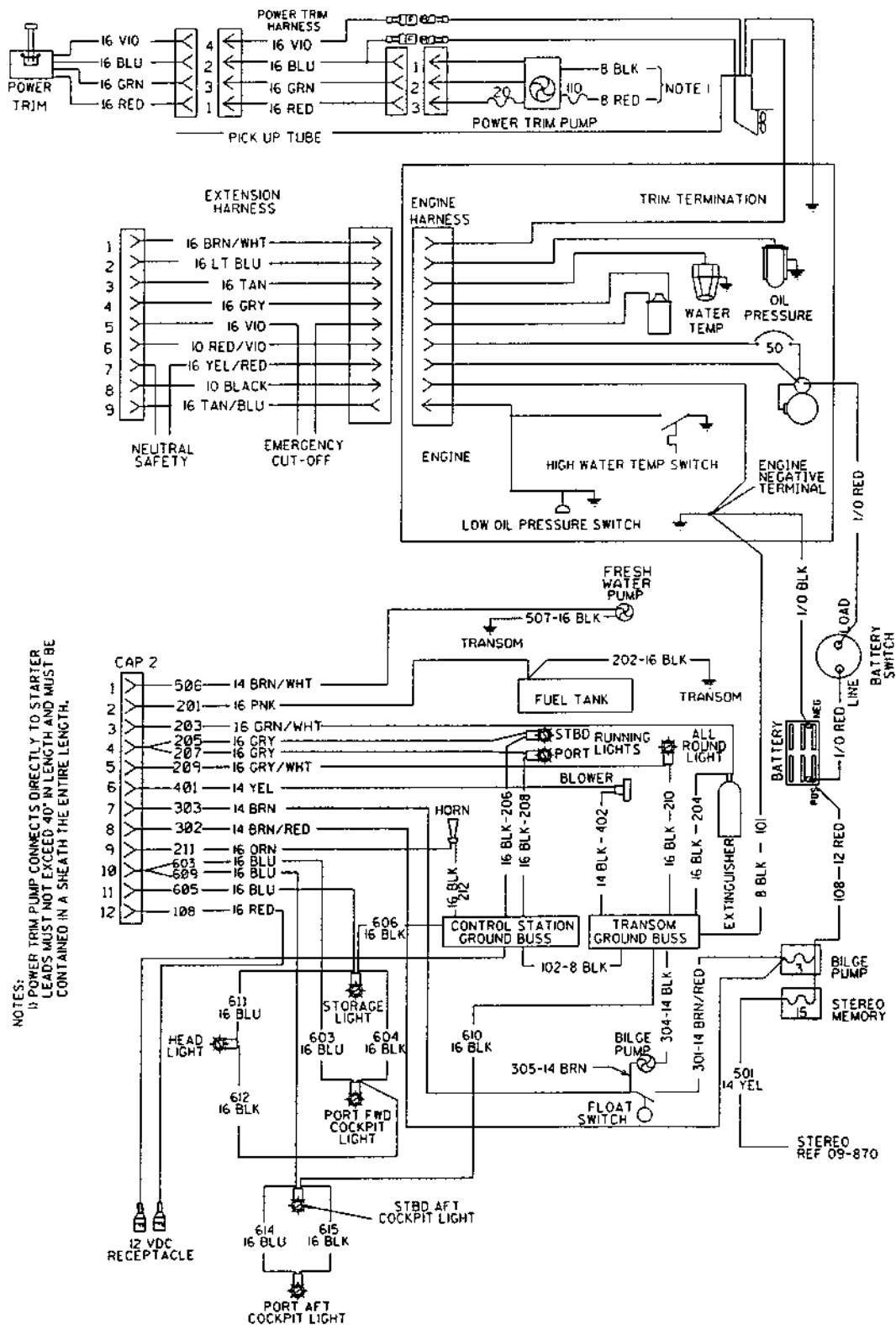

NOTES:
 1: POWER TRIM PUMP CONNECTS DIRECTLY TO STARTER
 LEADS MUST NOT EXCEED 40" IN LENGTH AND MUST BE
 CONTAINED IN A SHEATH THE ENTIRE LENGTH.

INTERNATIONAL HOMOLOGATIONS

This vessel and its systems have been constructed in accordance with standards and specifications in effect at the time of manufacture as published by the various regulatory authorities listed below.

1. Ministere De La Mer - France
2. Registro Italiano Navale - Italy
3. Det Norske Veritas - Norway
4. Securite des Nauires - Canada
5. J.C.I. (Japan Craft Inspection) - Japan
6. N.K.K. (Nippon Kaiji Kyokai) - Japan
7. B.S.I. (British Standards Institute) - England
8. Ministerio Obras Publicas Y Transporters - Spain
9. EC Directive - European Community

Further information may be obtained from Sea Ray® Customer Service. 1-800-SRBOATS.

